



Cobra Motorcycle Mfg.

240 Uran street
Hillsdale, MI 49242

(517) 437-9100 phone
(517) 437-9101 fax

TSB0208 CFD upgrade for 50's

November 8, 2007

Cobra has discontinued the CFD replacement hardware for all 2006-2007 Cobra 50cc models. When CFD friction material needs replacing it will be necessary to upgrade to 2008 CFD components available in a kit EKMU0005.

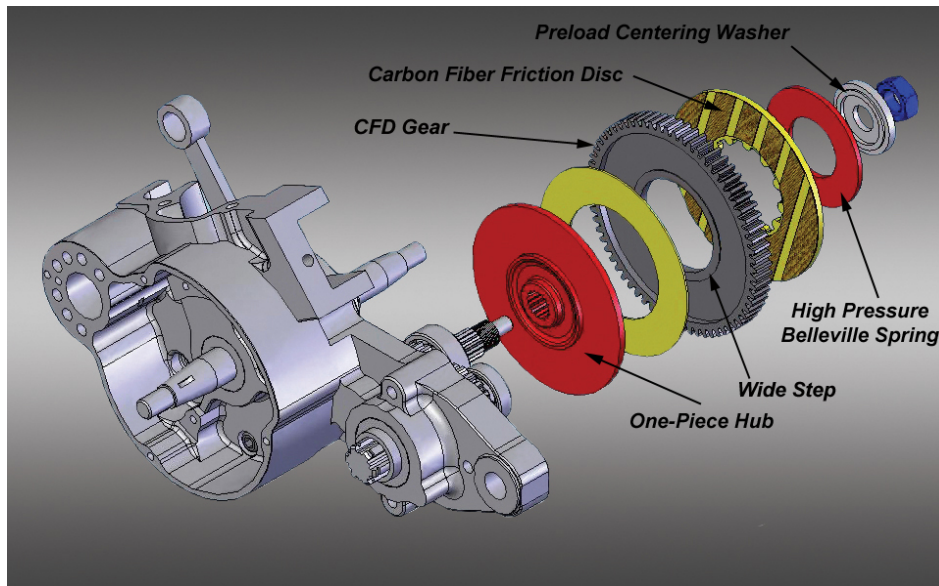

The kit includes the following parts:

- One-piece hub / pressure plate
- Single friction paper
- 08 Friction gear
- Bonded pressure plate
- High pressure Belleville spring
- Centering washer
- Blue nut

Upon assembly torque the blue nut to 55 ft-lb (75 N-m)

CAUTION:

The blue nut has left hand threads (turn clockwise to loosen)

CAUTION:

Install the CFD gear such that the wide step is 'in' toward the loose paper & one piece hub / pressure plate. Current production gears do not have a wide step on either side, and can be installed either way.

NOTE

After assembly confirm that slip torque is between 55-92 ft-lb (75-125 Nm) using Cobra CFD holding tool EAMU0004.