

DISCLAIMER OF WARRANTY

This motorcycle is sold "as is" with all faults, obvious or not. There are no warranties expressed or implied, including any warranty of merchantability and warranty of fitness for any particular purpose.

"WARNING"

THE COBRA CX50SR (KING) IS A COMPETITION MODEL ONLY AND IS NOT MANUFACTURED FOR, NOR SHOULD IT BE USED ON PUBLIC STREETS, ROADS OR HIGHWAYS.

THE USE OF THIS BIKE SHOULD BE LIMITED TO PARTICIPATION IN SANCTIONED COMPETITION EVENTS UPON A CLOSED COURSE BY A SUFFICIENTLY SKILLED RIDER AND SHOULD NOT BE USED FOR GENERAL OFF-ROAD RECREATIONAL RIDING.

IMPROPER USE OF THIS MOTORCYCLE CAN CAUSE INJURY OR DEATH.

THIS BIKE IS INTENDED FOR EXPERIENCED RACERS ONLY AND NOT FOR BEGINNERS.

IT IS YOUR RESPONSIBILITY AS THE OWNER OF THIS COBRA MOTORCYCLE OR AS THE PARENT, OR LEGAL GUARDIAN OF THE OPERATOR, TO KEEP THIS COBRA MOTORCYCLE IN PROPER OPERATING CONDITION.

THIS BIKE WAS DESIGNED FOR RIDERS THAT WEIGH LESS THAN 80 LBS WITH FULL RIDING GEAR AND SHOULD NOT BE OPERATED BY RIDERS THAT WEIGH MORE THAN THAT.

BE SURE THAT THE RIDER ALWAYS WEARS ADEQUATE SAFETY GEAR EVERYTIME HE OR SHE RIDES THEIR COBRA MOTORCYCLE.

IMPORTANT SAFETY NOTICE

WARNING

Failure to follow WARNING instructions could result in severe injury or death to the machine operator, a bystander, or a person inspecting or repairing the machine.

CAUTION:

A CAUTION indicates special precautions that must be taken to avoid damage to the machine.

NOTE:

A NOTE provides key information to make procedures easier or clearer.

Table Of Contents

GENERAL INFORMATION	5
SPECIFICATIONS - GENERAL.....	5
OPTIONAL COMPONENTS.....	6
SPECIFICATIONS - TORQUE VALUES.....	6
BREAK-IN PROCEDURE	8
STARTING PROCEDURE	9
MAINTENANCE	10
TIPS.....	10
SCHEDULE.....	11
REPLACING TRANSMISSION / CLUTCH LUBRICANT.....	12
PROPER CHAIN ADJUSTMENT.....	14
REAR BRAKE MAINTENANCE	14
AIR FILTER CLEANING.....	16
FORK OIL REPLACEMENT	19
FRICTIONAL DRIVE (CFD).....	20
PARTS	21
PARTS – AIRBOX & INLET SYSTEM.....	21
PARTS – BARS AND CONTROLS.....	22
PARTS - CARBURETOR.....	23
PARTS – COOLANT SYSTEM.....	24
PARTS – ELECTRICAL SYSTEM.....	25
PARTS – ENGINE – BOTTOM END AND TRANSMISSION.....	26
Parts – Engine Clutch and Kicker	27
Parts – Engine – Water Pump.....	28
Parts – Engine – Top End	29
PARTS – EXHAUST SYSTEM.....	30
PARTS – FORKS & TRIPLE CLAMPS.....	31
PARTS – FORKS – LEG ASSEMBLY	32
PARTS – FRAME I.....	33
Parts – Frame II	34

PARTS – FRONT BRAKES.....	35
PARTS – FRONT WHEEL.....	36
PARTS – PLASTIC BODYWORK & SEAT	37
PARTS – REAR BRAKE.....	38
PARTS – REAR WHEEL.....	39
PARTS – SHOCK.....	40
PARTS – SWINGARM ASSEMBLY.....	41
SERVICE	42
ENGINE SERVICE.....	42
Base Gasket Selection	43
Engine Removal	45
Complete Engine Disassembly Procedure.....	45
Top End Disassembly Procedure	46
Splitting the Cases	47
Engine assembly	47
CLUTCH	49
IGNITION	54
COOLING SYSTEM.....	56
FUEL & AIR SYSTEM	59
EXHAUST	61
BRAKES.....	62
FRONT FORKS.....	63
REAR SHOCK.....	65
TUNING	66
GEARING	66
SUSPENSION	68
CARBURETION.....	69
TROUBLESHOOTING	72
INDEX	73

General Information

Specifications - General

Items	CX50 SR
Dimensions	
Wheelbase	39" (991mm)
Wheel size	10" (254mm) rear, 12" (305mm) front
Seat height	26" (660mm)
Engine	
Type	2-stroke, single cylinder, reed valve
Cooling system	Liquid-cooled
Coolant	50/50 antifreeze-coolant / distilled water
Displacement	49.8 cc
Bore and stroke	39 mm x 41.7 mm
Ignition system	Digital Low Inertia Ignition
Spark plug	Champion 8339-1, 8332-1 hotter, 8904-1 colder
Gap	0.023" – 0.025" (0.58 – 0.64 mm)
Ignition timing	0.040" (1.0 mm) Before Top Dead Center (BTDC)
Fuel type	High octane pump gasoline RACE FUELS ARE NOT RECOMMENDED
Oil type	<i>Cobra Venom 2-cycle Race Oil</i>
Fuel / oil mix ratios	Between 32:1 and 40:1 (after engine Break-In)
Carburetion	19 mm Dell'Orto
Main Jet	95
Slow (Pilot) Jet	60
Float Height	16mm ± 0.5mm (0.63" ± 0.020")
Transmission	
Speed	Single
Final drive ratio	14/38 T
Chain	100 links 420
Transmission / clutch oil type	<i>Cobra Venom 3 Shoe Clutch Milk</i>
Quantity	235 – 350 ml (8 – 12oz)

Chassis		
Front tire		2.50 - 12
	Pressure	16 psi minimum
Rear tire		2.75 - 10
	Pressure	16 psi min. (20 psi for hard pack or rocky conditions)
Front fork		Cobra 30mm USD
	Fork oil type	SAE 5 weight
	Fork oil amount	107 ml (3.6oz)
Rear shock (std. settings)		Compression 16 clicks out Rebound 12 clicks out

Optional Components

Call your dealer, or the factory, for details

- Carburetor jets / reeds
- Flat clutch washers (see clutch service section)
- Pre filter for the airbox
- Sprockets
 - Front
 - Rear
- Suspension Springs

Weight of Rider (lb)	Fork Spring	Shock Spring
Less than 51	0.23 kg/mm KCKG1223	gray, 3.5 kg/mm SCKGFX35
51 - 60	0.25 kg/mm KCKG1206	yellow, 3.7 kg/mm SCKGFX37
Greater than 60	0.27 kg/mm KCKG1227	gold, 3.9 kg/mm SCKGFX39

- Tires, tubes or 'Tire Balls'

Specifications - Torque Values

Fastener	Torque Value			Size & Remarks
	ft-lb	in-lb	Nm	
Cylinder head nuts	8.8	105	12	M6 x 1.0

Crankcase bolts	8.8	105	12	M6 x 1.0
Spark plug	(SP)	(SP)	(SP)	M14 x 1.25
Stator bolts	2.1	25	2.8	M5 X 0.8
Stator cover bolts	1.7	20	2.3	M4 X 0.75
Clutch cover bolts	5.8	70	7.9	M6 X 1.0
Clutch nut	40	480	54	M10 x 1.25*
Clutch bolts	12	144	16	M6 x 1.0
CFD nut	55	664	75	½" x 20 LHT
Front axle nut	25	300	34	M12 x 1.25
Engine mount bolts	22	265	30	M8 X 1.25
Swingarm Pivot	21	250	28	M14 X 2.0
Shock Bolt	35	420	47	M10 x 1.5**
Water Pump Impeller	6	75	8	M5 x 0.8**
Water Pump Pulley	10	124	14	M6 x 1.0**
Intake manifold bolts	4.6	55	6.2	M6 X 1.0
Rear Axle Bolt	25	300	34	M12 X 1.25
Rear Sprocket Bolts	18	216	24	7 mm**
Fork cartridge rod	12	144	16	
Triple clamp bolts (bottom)	6	72	8	M6 x 1.0
Triple clamp bolts (top)	9	108	12	M6 x 1.0
Fork cap	5	60	6.7	1.25" x 18
Ignition rotor nut	35	420	47	M10 x 1.25*

* Apply high strength thread locking agent when installing

** Apply medium strength thread locking agent when installing

(SP) To apply the proper torque to the spark plug when inserting, one must first screw the spark plug in until the metal gasket ring causes resistance and then turn another 1/8 to ¼ turn.

Break-In Procedure

Your Cobra CX50 SR is a close-tolerance high performance machine and break-in time is very important for maximum life and performance. The CX50 SR can be ridden hard after the first ½ hour break-in time but it is recommended that no adjustments are made to the carburetion or suspension until the full 8 hours of bike break-in has elapsed. Also, after the engine, transmission, and drive train have been broken-in for the full 8 hours, the bike will be faster!

Use a fuel / oil mixture of 32:1 for the full 8 hour break-in period. Be sure to use high-octane pump gas, with Cobra's specially formulated *Cobra Venom 2-cycle Race Oil*. (Part # MCMUOL02)

CAUTION:

Failure to use proper fuel, oil, or fuel/oil mixture may result in premature engine wear or damage to the machine.

Adhering to the following break-in schedule will result in long lasting high performance machine.

- Start bike on stand
- First 5 minute period, operate the bike on the stand with a combination of idle and high RPM operation. (avoid prolonged high RPM but spin the rear wheel good at least once or twice per minute)
- Allow bike to cool
- Ride for 15 minutes maximum (avoid prolonged high RPM operation and avoid abusing the clutch with throttle blipping.
- Cool and inspect bike for loose fasteners.
- Next ½ hour of operation, avoid prolonged operation at Wide Open Throttle.
- After 1 hour of operation
 - Check for loose bolts and nuts on the bike and retighten as necessary (proper torque values are listed under Specifications).
 - Clean the carburetor bowl.
 - Change the transmission / clutch lubricant.
- After 8 hours of operation
 - Change the fork oil.
 - Have a Certified Cobra Mechanic change the shock oil.
- Your bike is now ready for the highest level of competition!

NOTE:

During break-in the bike will likely lose some engine coolant through the radiator overflow hose. Losing up to 4 oz (120 ml, ½ cup) is normal. Proper coolant level will cover the top of the radiator cores. Removing the radiator cap and looking inside is the only way to check the coolant level.

WARNING

Never open the radiator cap of a machine that has a hot or warm engine or one that has recently been ridden. Burning and scalding could occur.

CAUTION:

It is important that the radiator cap is installed correctly and completely otherwise engine damage could occur.

Starting Procedure

Before starting the machine inspect the following:

- Check for proper tire pressure in both tires.
- Observe the chain tension and adjust if necessary.
- Observe the coolant level and fill if necessary.
- Verify that the chain rollers and sliders do not have improper wear.
- Verify that the handlebars are tight.
- Check the throttle for smooth operation and that it 'clacks' shut properly.
- Check for loose bolts and nuts, and re-torque as necessary.
- Verify that the air filter is clean and properly saturated with oil.
- Insure that the fuel tank contains an adequate volume of fuel / oil mixture to complete the distance required. (High octane pump gas with Cobra's specially formulated *Cobra Venom 2-cycle Race Oil*)
- Turn the fuel on by rotating the fuel petcock knob to the vertically downward position (reserve position is horizontally forward)

CAUTION:

For best results from your Cobra Motorcycle use only the recommended fuels. Testing has shown that most 'race' fuels actually degrade performance.

WARNING

Always wear a helmet and other protective riding gear.

When your pre-ride inspection is complete the bike may be started. For a cold engine follow this procedure.

1. Place the motorcycle on a stand of sufficient strength that positions the motorcycle in a level upright position with the rear wheel off the ground.
2. Pull up the choke knob and turn it to lock it.
3. Kick start the engine.
4. Rev the engine in short spurts, turning the throttle no more than 1/4 open until the engine will run without the choke.
5. Verify a functional engine shut-off switch by shutting off the engine.
6. Restart the engine and proceed with riding when the engine is sufficiently warm (i.e. the side of the cylinder is warm to touch).

CAUTION:

Never rev an engine full throttle when it's cold or slightly warmed up. Also, for best clutch performance, warm up the bike before taking off.

⚠ WARNING

This is a high performance race motorcycle. Too much application of throttle will likely land your little racer on his or her arse. Fenders can be replaced but bruised egos and other body parts take longer.

CAUTION:

Cobra recommends that you tell your child to take it easy the first couple of minutes in practice until the engine comes up to full operating temperature.

CAUTION:

Make sure your riders' foot is not resting on the foot brake while they are riding.

Maintenance

It is important that you adhere to this maintenance schedule so as to promote the longevity of your Cobra Motorcycle.

Tips

1. Cobra lubricants:
 - a. Cobra Clutch Milk has been specifically formulated to meet the stringent temperature, frictional, and load requirements unique to the high engine speeds and centrifugal clutch of the Cobra 50cc motorcycles.
 - b. Cobra Two Cycle Oil exceeds the JASO FD & ISO-L-EGD specifications, which are the worlds most stringent requirements on lubrication, detergency, and smoke. Use only a 2-cycle oil that meets these specifications.
2. Filling your transmission with more than 8.0 oz (235 cc) of lubricant may help to transfer heat from the clutch. Filling with more than 12 oz (350 cc) will degrade performance.
3. The cylinder base gasket has been 'fitted' for your engine. The code number stamped into the engine cases will guide you to what thickness base gasket is required during a common top end service. See the service section of this manual to correspond a code number with a base gasket part number.
4. Evaluate the bikes jetting only after it has been warmed up to race temperatures.
5. A properly maintained machine is safer, faster, and more fun to ride.
6. New chains will stretch on first use. Never install a new chain prior to a race. Always 'break' them in during practice.

7. Your Cobra Motorcycle has a 10 digit VIN (Vehicle Identification Number). The first two digits indicate the model and the seventh indicates the model year (MY).
 - a. Example, ACxxxx9xxx is a 2009 MY CX50 SR.

Schedule

- Between each ride
 - Check the air filter (clean and re-oil as necessary).
 - Insure the smooth operation of the throttle cable (throttle soundly 'clacks' shut).
 - Check for frayed strands of the throttle cable inside the throttle housing and replace if necessary.
 - Check for adequate tire pressures and adjust if necessary.
 - Check all nuts and bolts for proper torque and re-torque if necessary.
 - Spray all moving parts with WD40 or other light oil.
 - Check drive chain for
 - Proper tension and adjust if necessary.
 - Adequate lubrication and lubricate if necessary.
 - Insure that the ignition stator and rotor are clean and dry.
 - Check the frame for cracks in the metal or cracks in the paint that might indicate that the metal has been stressed beyond it's safe limits. Replace or get properly rewelded as necessary.
 - Check the rims for signs of stress, like cracks around the rim, spokes and hub.
- Every 2 hours of operation
 - Replace the transmission oil.
- Every 10 hours of operation
 - Replace the fork oil.
 - Have the shock oil replaced by a Certified Cobra Mechanic.

CAUTION:

1. Because of the amount of heat generated by the clutch and engine during extended periods of riding, it is advisable to remove the ignition cover afterward to allow the ignition to cool off. The heat transfers through the cases and can damage the stator as it cools off because of lack of airflow around the stator.
2. If you ever need to weld anything on the bike, disconnect the spark plug cap, unplug the ignition, disconnect the kill switch, scrape the paint bare near the area to be welded and put the ground clamp as close to the area to be welded as possible.

WARNING

Be sure the fuel tank and carburetor have been removed and safely located away from the welding process.

3. The frame is 4130 Chrome Moly and it is important to weld it with the proper rod and heat settings set as light as possible. Cobra recommends replacing the frame with a new one if the old one becomes damaged. Use ER70S6 filler if welding on the frame.
4. If your kick-starter lever does not return properly, first try loosening the six kick/clutch cover screws ½ turn. Hold the kick lever ½ way down while retightening the six screws starting for the center and working out.
5. Inspect CFD slip torque every 10 hours of riding or replace the friction papers and the load spring (Bellville spring) every 20 hours.
6. Check proper clutch engagement before and after each ride. If the clutch is engaging properly DO NOT feel the need to take the clutch apart to; measure the spring stack, clean the stack, replace the springs, etc... Cobra has worked real hard to make a clutch that is low maintenance and so only take it apart if it NEEDS to be maintained.

Replacing Transmission / Clutch Lubricant

Tools needed:

- Minimum of 235 ml (8 oz) *Cobra Venom 3 Shoe Clutch Milk* (Part # MCMUGF01).

NOTE:

Up to 350ml (12 oz) can be applied without hurting performance.

Procedure:

1. Begin this procedure with a bike that has been ridden more than 5 minutes but less than 10 minutes. It is desired to have the engine warm enough so that the oil is 'runny' but not so hot that there is risk of being burned by the engine or the oil.

WARNING

Hot oil and hot components on the motorcycle may cause burns.

2. Lean bike against something or set on stand with oil drain hole.
3. Remove the oil drain plug located on the right side of the engine, on the clutch cover, near the brake lever (figure 1).

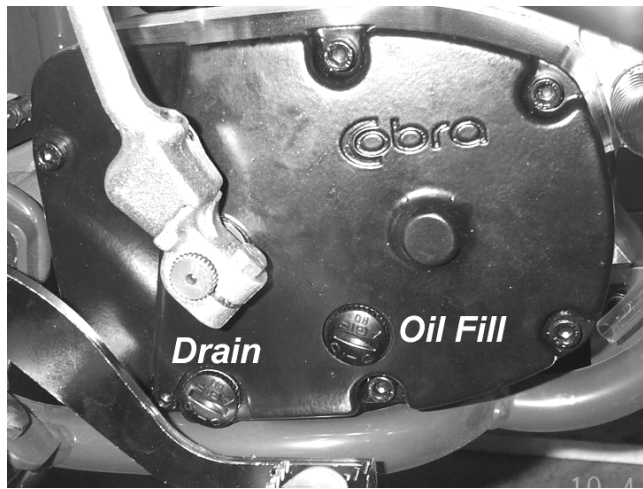

Figure 1

4. After it has drained, reinstall the plug, being sure that the gasket is in place.
5. Reapply oil from oil fill plug 235 cc (8.0 oz) *Cobra Venom 3 Shoe Clutch Milk* thru the oil fill plug.

NOTE:

Putting additional oil, up to 350 ml (12 oz), can help clutch life. More than 350 ml (12 oz) will degrade engine performance.

NOTE:

Lean bike over onto it's left hand side so that the clutch cover is up unless you have a squeeze bottle.

6. Reapply the oil fill plug, hand tight, being sure the gasket is in place.

CAUTION:

Cobra has spent considerable time and money developing the proper lubrication to handle the harsh environment of the automatic clutch and transmission of this motorcycle. Cobra's specially developed *Cobra Venom 3 Shoe Clutch Milk* (Part # MCMUGF01) was formulated to provide superior lubrication and cooling capability over extended periods of time and is the recommended lubricant for your Cobra motorcycle.

Proper Chain adjustment

Tools required for chain adjustment

- 19 mm wrench or socket
 - 13 mm wrench or socket
1. Make sure that the rear wheel is aligned properly.
 2. For proper adjustment, the chain should have 35 mm (1 3/8") free movement just behind the chain block with no load on the bike (figure 2)

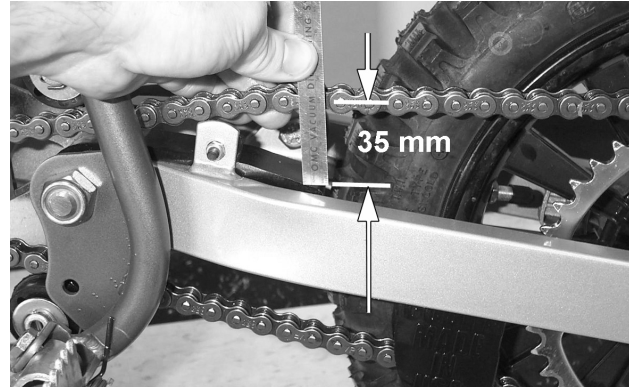

Figure 2

CAUTION:

Sit on the bike and verify that the chain has a minimum of 12mm (1/2") free movement when the chain is at it's tightest point.



3. If the chain requires adjusting, loosen the axle with a 19 mm wrench and tighten the chain by rotating the adjustor bolts clockwise (CW) or loosen the chain by rotating the adjustor bolts (CCW).
4. Retighten the axel bolt to 25 ft-lb (34 Nm).
5. Retighten the adjustor bolt

Figure 3

CAUTION:

Always check rear brake adjustment and free-play after adjusting the chain.

Rear Brake Maintenance

CAUTION:

Too little brake pedal free-play will allow the brake pads to drag causing the pads to wear prematurely and possible engine component failures. Too much free-play will not allow the rider to apply the brakes quickly.

1. Set pedal height/position first, then
2. Set pedal free play.

Brake pedal height can be adjusted with the bolt and nut located under the rear of the brake pedal. The free-play is adjusted with the adjustable plunger on the end of the brake pedal.

CAUTION:

Use only DOT 4 brake fluid

Setting rear brake pedal position (see figure 2b):

1. Loosen the lock nut (10mm wrench).
2. Adjust the brake lever stop (10mm wrench) so that the lever is comfortably reachable in both:
 - a. Standing riding position, and
 - b. Sitting riding position.
3. Tighten the lock nut (10 mm wrench).

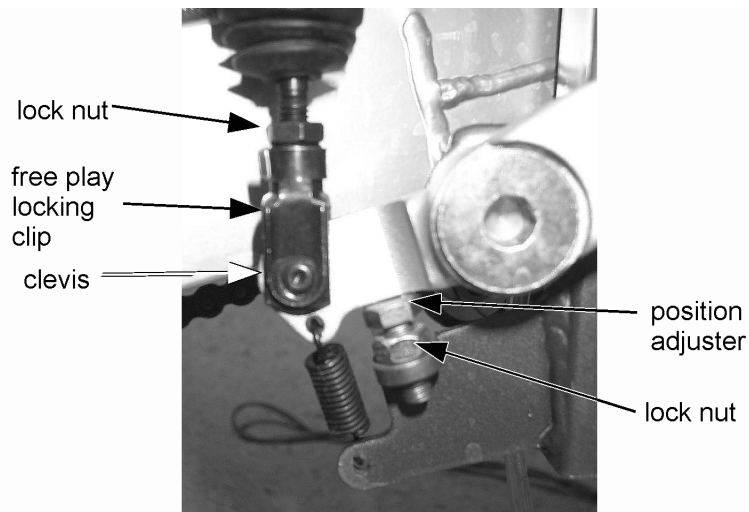

Figure 2b

CAUTION:

Adequate pedal free play is required so that the brake pads do not drag on the rotor. 1" MINIMUM.

⚠ WARNING

Make sure that the free play locking clip is installed such that one must push forward, toward the front of the bike, to remove. Otherwise the clip is apt to come undone while riding.

To adjust (see figure 2b):

1. Loosen the lock nut (10mm).
2. Undo the free play locking clip from around the brake adjuster (plunger), with your hand by pushing it forward.
3. Slide the pin of the locking free play locking clip from the brake lever
4. Adjust as needed by rotating the clevis on the end of the adjuster (plunger).

NOTE:

Turning the clevis Clockwise will lengthen the adjuster (plunger), removing free play from the system, and turning the clevis Counter-Clockwise will shorten the adjuster (plunger) adding free play to the system.

Air Filter Cleaning

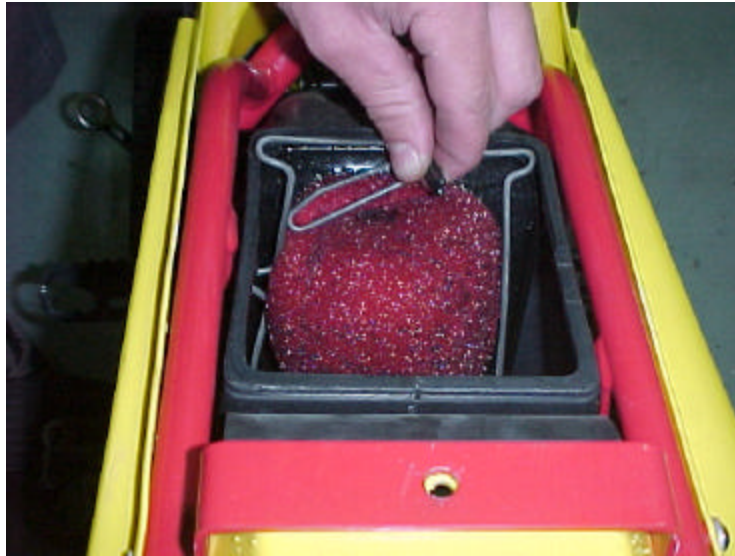

Figure A1

- Remove the seat (unscrew the knob under the seat & rear fender)
- Squeeze the two tabs together as shown in figure A1 and pull the wire retainer up and out of the air box
- The filter may now be pulled from the airbox
- Clean the airbox of dirt and clean the filter sealing surface of the old sealing grease.

CAUTION:

Pay particular attention to clean any particles from the airbox between the filter location and the carburetor.

NOTE:

Cobra has available a carburetor cover that allows easy cleaning of the airbox.

1. Remove the air boot
2. Install the cover (RCMU0109) over the carburetor inlet
3. Spray out the airbox.

⚠ WARNING

Do not clean the air filter with gasoline or other highly volatile petroleum product. Diesel fuel or kerosene would be preferred but caution should still be taken. Hot soapy water works well.

1. Clean the filter in hot soapy water to remove all dirt particles.
2. Allow it to dry thoroughly.
3. Saturate with filter oil and remove excess.

NOTE:

It's very important to oil your filter consistently each time because varied amounts of oil will change your carburetor jetting.

4. Apply grease to the black sealing surface of the filter and reinstall.



Figure A2

5. Squeeze the two finger tabs together on the wire retainer and install into the airbox as in figure A2
6. Push the wire retainer down until it bottoms, making sure the two bottom tabs on the retainer go through the two associated holes in the bottom of the airbox.
7. Push the two top retainer arms out so that they properly insert into each side hole.

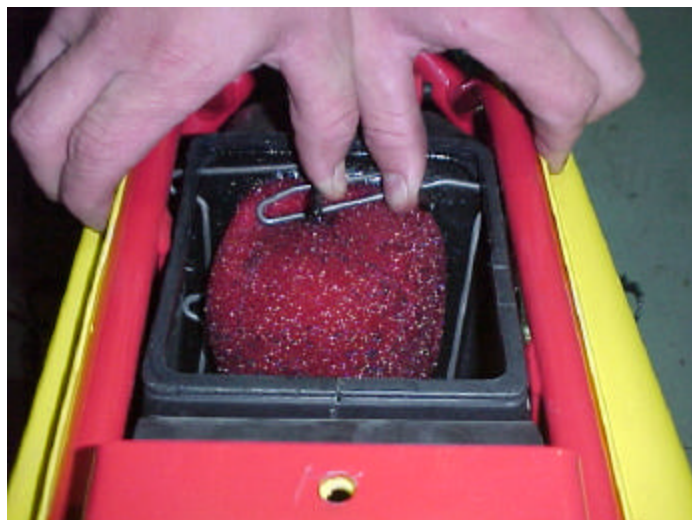

Figure A3

CAUTION:

If the side arms do not align with the associated holes it is quite likely that the legs did not make it into the holes. Realign and try again.

8. When properly installed, the filter and retainer should look like figure A4.



Figure A4

NOTE:

Make sure you change or clean your filter after each moto. We recommend carrying multiple filters in your toolbox, one for each practice session and moto.

Fork Oil Replacement

Tools required

- Two 19 mm wrenches or sockets
- 4 & 5 mm hex key (Allen wrench)
- 25mm wrench or socket
- 5 wt fork oil

Disassembly procedure

1. Remove the front wheel (19 mm wrench).
2. Remove the brake caliber from the fork leg (4 mm hex key).
3. Loosen the fork caps (25mm socket).
4. Remove the fork legs from the triple clamps (5 mm hex key).
5. One leg at a time
 - a. Remove the fork cap from the leg.
 - b. Separate the fork cap from the damper rod.
 - c. Pull out the fork spring.
 - d. Place upside down over a suitable pan, tray, or container.
 - e. Work the damper rod up and down several times.
 - f. Allow it to drain completely.

Assembly procedure

1. Fill the fork leg with 3.6oz (107 ml) 5 wt fork oil.
2. Measure the fork oil level to the top of the fork tube with the leg collapsed, and record for tuning purposes.
3. Install the fork spring.
4. Reconnect the damper rod to the fork cap (12 ft-lb, 16 Nm).

CAUTION:

The damper rod is hollow and will break if the nut is over tightened.

5. Reinstall the for cap into the fork leg (5 ft-lb, 6.7 Nm)
6. Reinstall the fork legs into the clamps (6 ft-lb, 8 Nm).
7. Reinstall the brake caliper.
8. Reinstall the front wheel (25 ft-lb, 34 Nm).

Frictional Drive (CFD)

The Cobra Frictional Drive (CFD) is essentially a slip clutch that dissipates torque spikes transmitted from the rear wheel to the rest of the drive line and engine. Instead of these torque spikes potentially damaging internal components, the CFD allows the transmission to slip with respect to the engine. For this to occur, the CFD must function properly by 'slipping' between a minimum torque value, and a maximum torque value.

The slip torque of the CFD should be checked every 5 hours of operation.

Slip Torque	Ft-lb	N-m
Minimum	55	75
Maximum	92	125

To properly measure the torque at which the CFD (Cobra Frictional Drive) slips, one first access the slip clutch by draining the oil and removing the cover exposing the CFD. Next, brace the CFD gear from turning with a suitable device (Cobra tool EAMU0004 or similar).

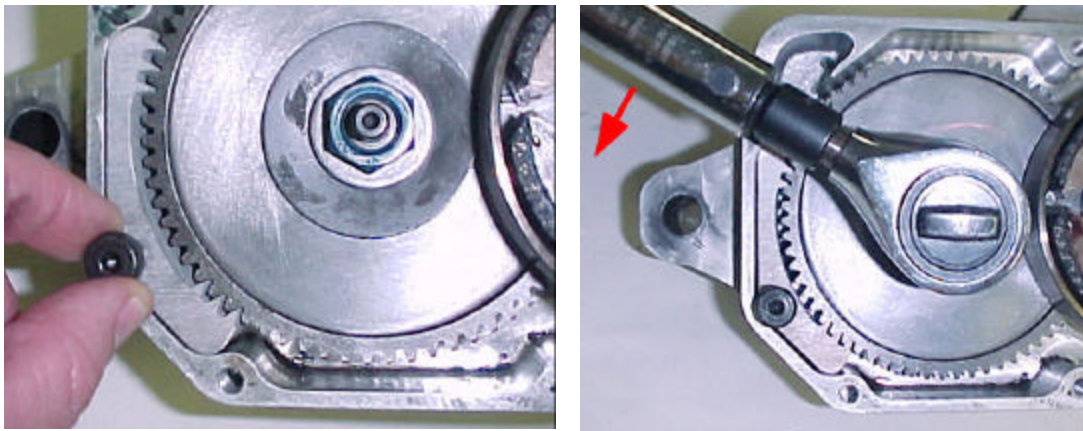

Using a beam style torque wrench, turn the torque wrench counter clockwise and observe the torque measurement when the shaft slips relative to the gear. Using a preset value torque wrench, adjust the setting **55 ft-lb (75 Nm)** and observe whether the wrench clicks first or the shaft slips. If the shaft slips first, the slip torque is below 55 ft-lb and the CFD needs servicing. If the wrench clicks first, the CFD is of acceptable value.

NOTE

To loosen and tighten the blue CFD nut, use a strong wooden object (large hammer handle) through the spokes of the rear wheel as a brace against the swingarm to stop transmission shaft rotation.

CAUTION:

The blue CFD nut has left hand threads which require clock-wise rotation to loosen.

Parts

Parts – Airbox & Inlet System

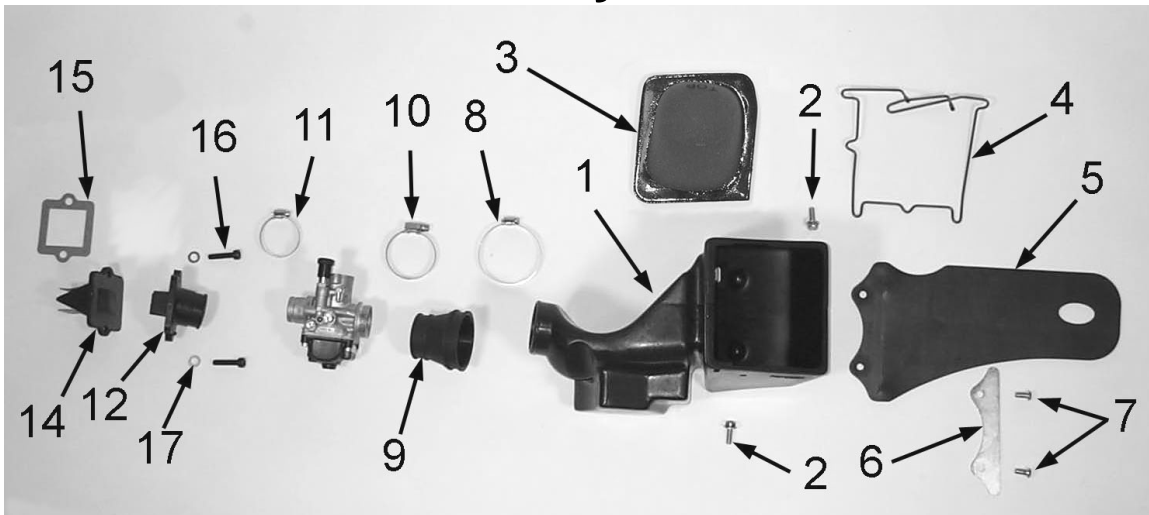

Coolant System		
REF #	PART #	DESCRIPTION
1	RCKG0501	AIRBOX
2	HCBF0616	M6X16 FLANGE HEAD BOLT
3	RCKG0512	AIR FILTER
4	RCKG0503	FILTER RETAINER
5	TCKG0004	MUDFLAP – AIRBOX
6	TCKG0105	BRACKET – MUDFLAP
7	HCBB0612	M6X12 BUTTON HEAD BOLT
8	MCKGHO03	HOSE CLAMP – AIRBOX TO BOOT
9	RCKG0505	AIR BOOT
10	MCKGHO01	HOSE CLAMP – BOOT TO CARB
11	MCKGHO04	HOSE CLAMP – CARB TO MANIFOLD
12	RCCS0002	INLET MANIFOLD
12	ECKG0203	INLET MANIFOLD
14	ECKG0202	REED CAGE ASSEMBLY WITH REEDS
NOT SHOWN	ECKG0205	REED REPLACEMENT KIT
15	ZCMU0132	GASKET – REEDS TO ENGINE
16	HCBC0625	M6X25 SOCKET HEAD CAP SCREW
17	HCWF0601	6MM FLAT WASHER
NOT SHOWN	RCCM1301	VELOCITY STACK (SCREWS ONTO CARB)

Parts – Bars and Controls

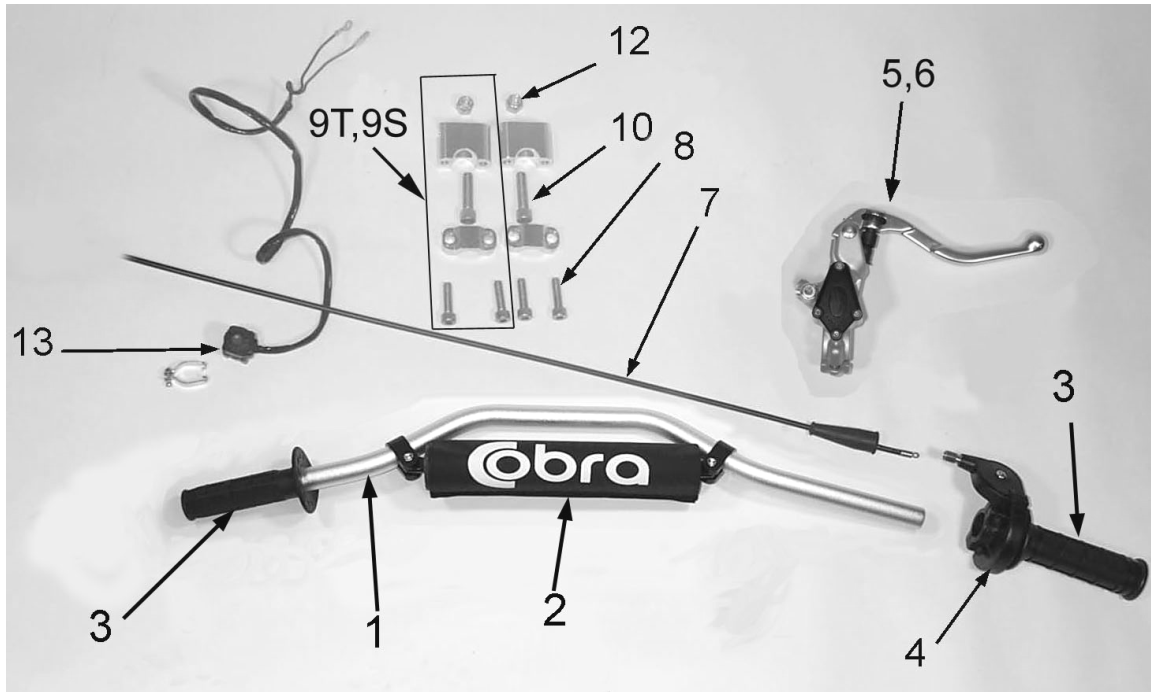

Bars and Controls		
REF #	PART #	DESCRIPTION
1	FAMU0011	HANDLEBAR - ALUMINUM
2	MCMU0001	OPTIONAL CROSS BAR PAD
3	TCMU0008	GRIPS (SET OF TWO)
4	FCMU0066	THROTTLE ASSEMBLY
NOT SHOWN	FCMU0021	THROTTLE COVER
5	BCKG0023	ALLOY BRAKE LEVER W/BALL
6	BCKG0024	BRAKE PERCH ASSY W/LEVER & BALL
NOT SHOWN	BAKG0004	SHIELDED BRAKE HOSE ASSEMBLY
7	FCMU0019	THROTTLE CABLE
8	HCBC0806	SOCKET HEAD CAP SCREW M8 X 30 (4 PER)
9S	TKMU0404M	BAR MOUNT KIT, SHORT (2 REQ'D)
9T	TKMU0403M	BAR MOUNT KIT, TALL (2 REQ'D)
10	HCBC1001	M10X45 SOCKET HEAD CAP SCREW (2 REQ'D PER BIKE)
12	HCNL1001	M10 LOCK NUT
NOT SHOWN	HCBH0816	M8 X 16 HEX HEAD BOLT
NOT SHOWN	HCWF0801	8MM FLAT WASHER
13	FCMU0033	KILL SWITCH ASSEMBLY

Parts - Carburetor

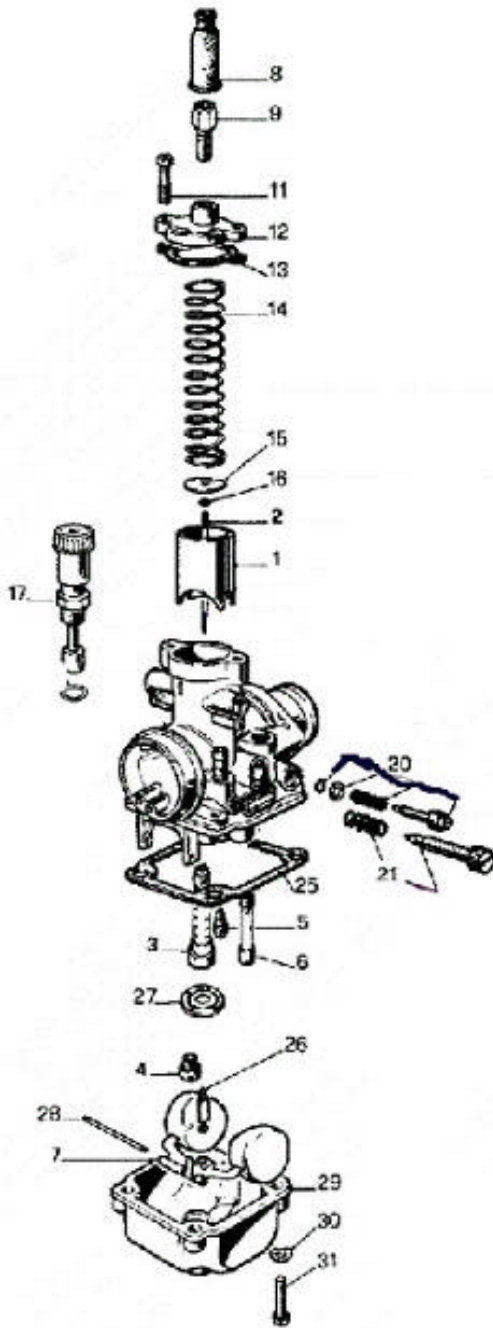

Carburetor		
REF. #	PART #	DESCRIPTION
1	RCMU0305	CARB SLIDE
2	RCMU0601	NEEDLE
3	RCMU00	ATOMIZER 2.62 AU
4	RCMU00xx	MAIN JET, xx denotes size
5	RCMU00xx	PILOT JET, xx denotes size
6		CHOKE JET
7	RCMU0301	FLOAT
8	RCMU0102	RUBBER CABLE CAP SEAL
9	RCMU0003	CABLE ADJUSTOR
11	RCMU0006	TOP CARB SCREW
12	RCMU0106	CARB TOP
13	ZCMU0007	TOP CARB GASKET
14	RCMU0004	SLIDE SPRING
15	RCMU0028	NEEDLE RETAINER PLATE
16	RCMU0007	NEEDLE CLIP
17	RCMU0204	CHOKE ASS'Y. 2001 CM
20	RCMU0009	FUEL MIXTURE SCREW
21	RCMU0011	IDLE ADJUSTMENT SCREW
25	RCMU0103	FLOAT BOWL GASKET
26	RCMU0107	FLOAT NEEDLE
27	RCMU0012	DIFFUSER
28	RCMU0016	FLOAT RETAINER PIN
29	RCMU0108	FLOAT BOWL
30	HCWF0401	WASHER 4MM FLAT
31	RCMU0201	SCREW - FLOAT BOWL
NOT SHOWN	RCCM1301	VELOCITY STACK -05
NOT SHOWN	MCKGHO01	CLAMP - CARBURETOR TO FILTER
Not Showr	FCMU0026	FUEL LINE, 5"
Not Showr	MCMUCL04	HOSE CLAMPS - FUEL LINE
Not Shown	RCMU0018	CARBURETOR COMPLETE 19 mm
Not Shown	RCMU0022	VENT HOSE 2" EACH

Parts – Coolant System

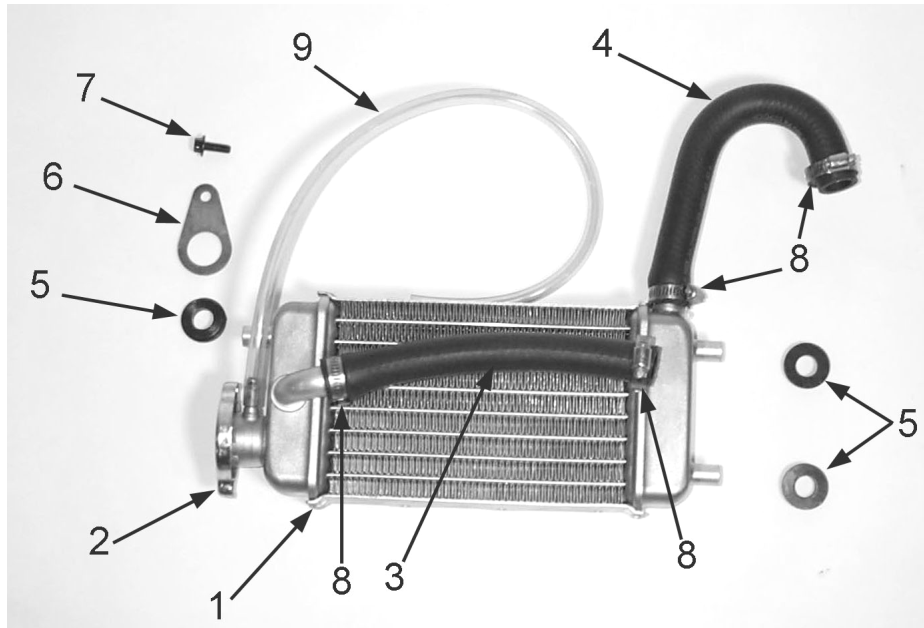

Coolant System		
REF #	PART #	DESCRIPTION
1	FCKG0036	RADIATOR WITH CAP
2	FCMU0047	RADIATOR CAP (2 ears or ribbed)
3	MCMUHO05	RADIATOR HOSE, TOP, LEFT
4	MCKGHO02	RADIATOR HOSE, BOTTOM, RIGHT
5	MCMUGR03	MOUNTING GROMMET (3 PER)
6	FCMU0006	RADIATOR MOUNTING BRACKET (TEARDROP)
7	HCBF0616	FLANGE HEAD BOLT M6X16
8	MCMUCL07	HOSE CLAMP (4 REQ'D)
9	FCKG0214	RADIATOR OVERFLOW HOSE, 22"
Not Shown	MCMUCL05	HOSE CLAMP FOR OVERFLOW HOSE
Not Shown	FCKG0001	LOUVER
Not Shown	HCSP0002	PUSHPIN (2 REQ'D)
Not Shown	HCCN0000	5 MM CLIP NUT

Parts – Electrical System

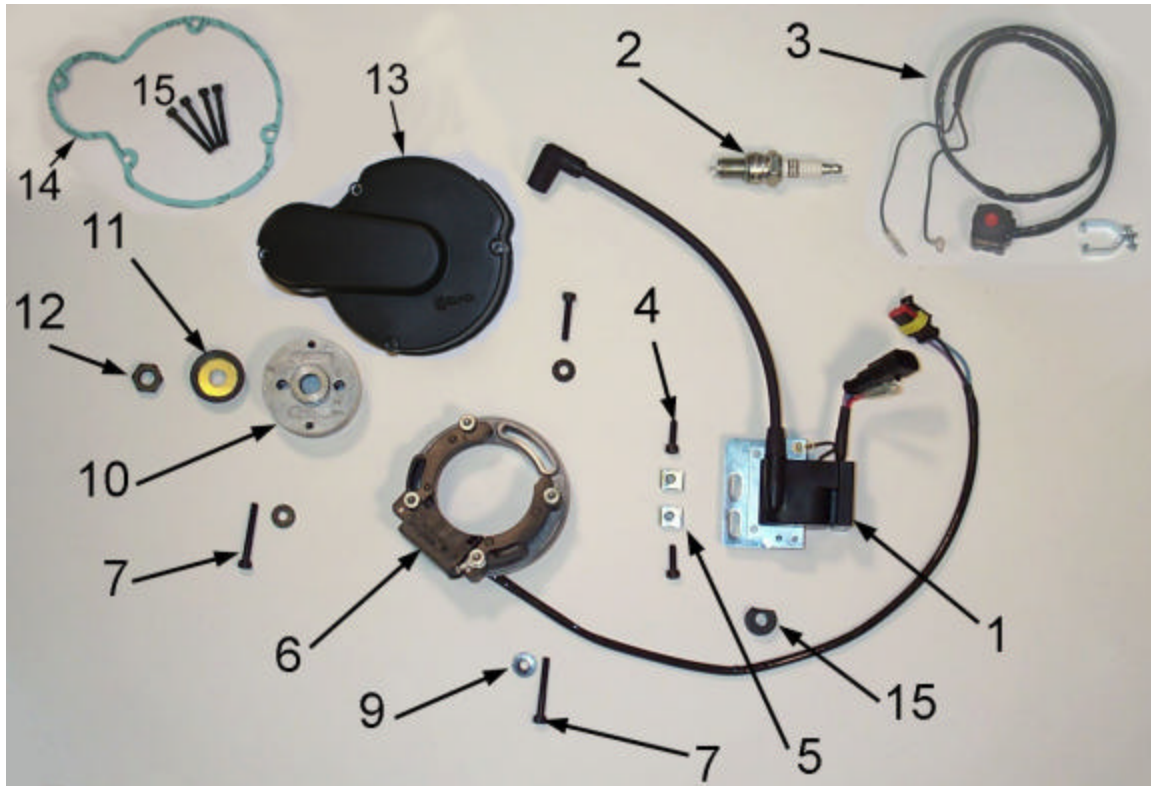

Electrical System		
REF #	PART #	DESCRIPTION
1	IAMU0005	COIL W/SPARK PLUG CAP
2	ECMU0065	SPARK PLUG, CHAMPION (8339-1)
2H	ECMU0067	OPTIONAL HOTTER PLUG (8332-1)
2C	ECMU0066	OPTIONAL COLDER PLUG (8904-1)
3	FCMU0033	KILL SWITCH ASSEMBLY
4	HCBC0502	5X20MM SHCS (2 REQ'D)
	HCNL0501	5MM LOCK NUT (2 REQ'D)
	HCWF0501	5MM FLAT WASHER (2 REQ'D)
	HCWP0002	SPECIAL WASHER (2 REQ'D)
5	HCCN0000	5MM CLIP NUT (MAY NOT BE USED)
6	ICMU0018	STATOR WITH GROMMET
7	HCBC0535	5mm x 35 SOCKET HEAD CAP SCREW (2 REQ'D)
8	HCBC0525	5mm x 25 SOCKET HEAD CAP SCREW
9	HCWF0504	WASHER FOR STATOR (3 PER)
10	ICMU0036	ROTOR – LOW INERTIA
NOT SHOWN	ICMU0012	WOODRUFF KEY
11	ECKG0042	PULLEY, WATERPUMP CRANK
12	HCNS1001	NUT 10MM
13	ECCS0001	IGNITION COVER
14	ZCCS0002	GASKET – IGNITION COVER
15	HCBC0402	M4X35 SHCS (4 REQ'D)

Parts – Engine – Bottom End and Transmission

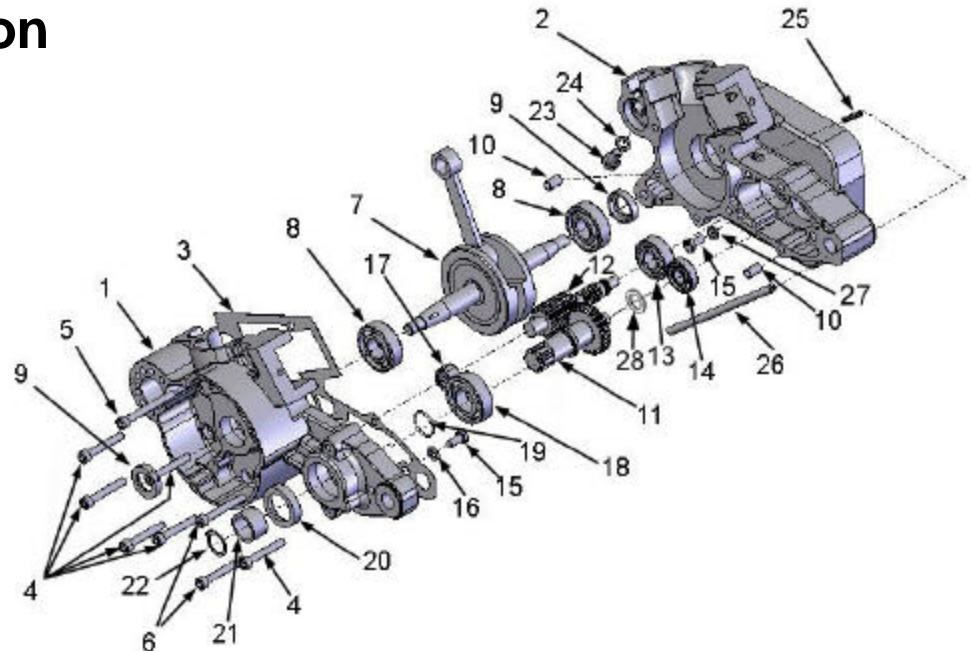

Engine Bottom End and Transmission		
REF #	PART #	DESCRIPTION
1	EKES0001	CRANKCASE SET CMPLT 50CC 09 KING
2	EKES0001	CRANKCASE SET CMPLT 50CC 09 KING
3	ZCMU0601	GASKET, CRANKCASE CENTER
4	HCBC0605	6X40MM SOCKET HEAD CAP SCREW (6 REQ'D)
5	HCBC0608	6X55MM SOCKET HEAD CAP SCREW (1 REQ'D)
6	HCBC0606	6X45MM SOCKET HEAD CAP SCREW (2 REQ'D)
7	ECMU0038	CRANKSHAFT
8	ECMU0016	BEARING, CRANKSHAFT
9	ECMU0118	SEAL, CRANKSHAFT
10	HCDP1401	DOWEL (SOLID), ENGINE CASE ALIGNEMENT (2 REQ'D)
11	ECMU0099	OUTPUT SHAFT, TRANSMISSION WITH GEAR
12	ECMU0100	SECONDARY SHAFT, TRANSMISSION WITH GEAR
13	ECMU0001	BEARING, TRANSMISSION SECONDARY SHAFT
14	ECKG0031	BEARING OUTPUT SHAFT, RIGHT SIDE
15	HCBH0612	M6X12 HEX HEAD SCREW - BEARING RETAINER (2 PLACES)
16	HCWL0601	6MM LOCK WASHER
17	ECMU0020L	BEARING, TRANSMISSION PRECISION
18	ECKGBR01	BEARING, TRANSMISSION OUTPUT SHAFT
19	ZCDCOR01	O-RING, SPROCKET SPACER
20	ECMU0072	SEAL, OUTPUT SHAFT
21	ECMU0073	SPACER, SPROCKET
22	ECKGSR03	SNAP RING, SPROCKET
NOT SHOWN	PCKG0014	SPROCKET, 14 T
23	HCBH0805	M8X12 SCREW – COOLANT DRAIN
24	HCWC0000	COPPER GASKET
25	ECMU0533	FITTING, CRANKCASE VENT
26	ECMU0534	VENT HOSE, CRANKCASE, 9"
27	HCWF0316	WASHER – FLAT
28	ECMU0156	SHIM – OUTPUT SHAFT 50'S (MAY NOT BE NEEDED)

Parts – Engine Clutch and Kicker

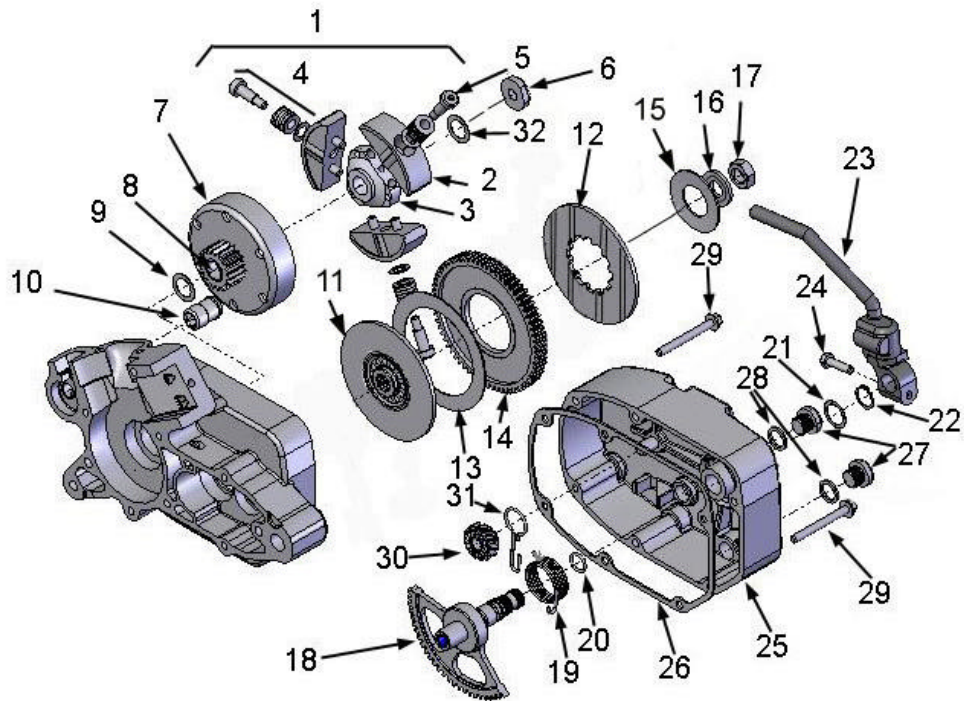

Engine – Clutch and Kick Starter		
REF #	PART #	DESCRIPTION
1	CAMU0005	CLUTCH COMPLETE
2	CAMU0013	CLUTCH SHOES (SET OF 3) WITH BOLT & WASHERS
3	CCMU0029	CLUTCH ARBOR
4	CAMU0010	SPRINGS, WASHER & BOLT (SET OF 3)
5	HCBS0004	CLUTCH BOLT (3 REQ'D)
6	ECMU0018	CLUTCH NUT, SPECIAL
7	ECMU00120	CLUTCH BASKET WITH NEEDLE BEARING
8	ECMU00119	CLUTCH BEARING
9	ECMU0040	CLUTCH TO HUB SPACER (0.030", 0.76MM)
	ECMU0040T	CLUTCH TO HUB SPACER (THIN – 0.015", 0.38MM)
10	ECMU0132	COOLANT FITTING
11	EAMU0010	CFD HUB / PRESSURE PLATE V2
12	ECMU0162	PRESSURE PLATE WITH FRICTION MATL, '08 STYLE
13	ECMU0138	FRICTION RING (BRASS), CFD
14	ECMU0166	GEAR, CFD '08 STYLE
15	ECMU0159	SPRING WASHER, CFD, 60MM OD
16	ECMU0169	CENTERING WASHER, CFD V2
17	HCNS1202	NUT, CFD (½-20 LEFT HAND THREAD – BLUE)
18	EAMU0001	KICKSTART GEAR & SHAFT
19	ECMU0116	SPRING, KICKSTART
20	ZCMUB014	O-RING KICK SHAFT (2 REQ'D)
21	HCWS1622	SHIM, KICK SHAFT
22	ECDC0036	SNAP RING, KICK SHAFT
23	ECDC0046	KICK LEVER W/BOLT & RUBBER
24	HCBF0620	6MM X 20 FLANGE HEAD BOLT
25	ECMU0115	CLUTCH COVER
26	ZCMU0030	CLUTCH COVER GASKET
27	ECMU0037	OIL FILL PLUG
28	ZCMU0005	GASKET, OIL FILL / DRAIN PLUG
29	HCBC0608	6MM X 55 SOCKET HEAD CAP SCREW (6 REQ'D)
30	ECMU0207	KICKSTART GEAR SMALL
31	ECMUSP01	KICK START DOG SPRING (PAPER CLIP)
32	HCWS1016	WASHER – KICK GEAR SPACING

Parts – Engine – Water Pump

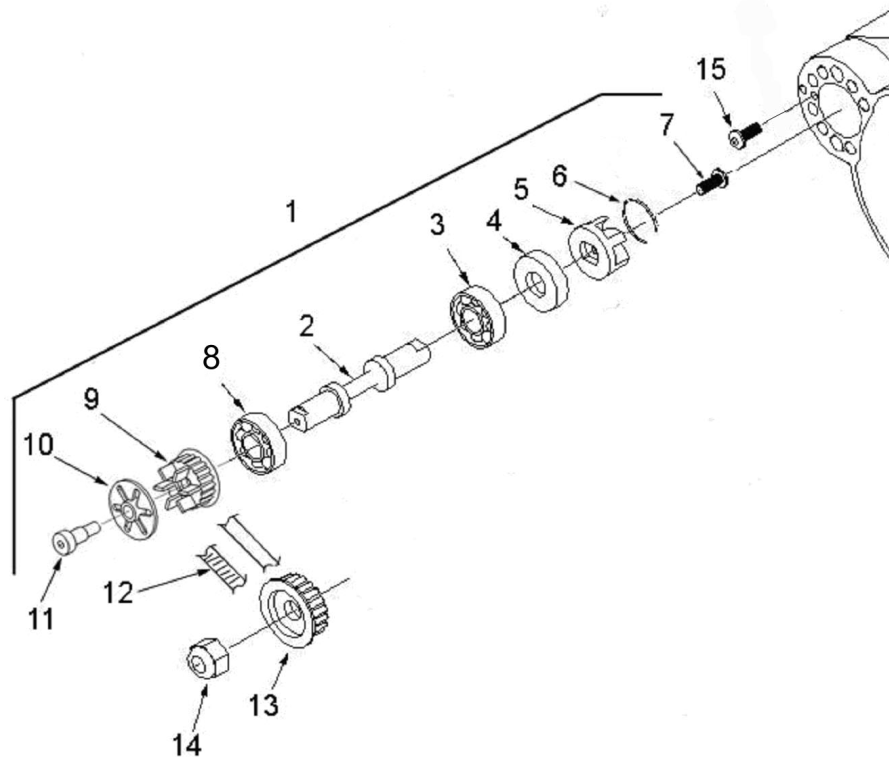

Engine – Ignition and Water Pump		
REF #	PART #	DESCRIPTION
1	EKMU0011	WATER PUMP KIT
2	ECKG0142	SHAFT, WATER PUMP
3	ECKG0072	BEARING, WATER PUMP
4	ECKG0074	SEAL, WATER PUMP SHAFT
5	ECKG0073	IMPELLER, WATER PUMP (ALUMINUM)
6	ECKG0004	RETAINER, WATER PUMP ASSEMBLY (MAY NOT BE NEEDED)
7	HCBC1512	5X12MM SHCS STAINLESS
8	ECMU0167	BEARING –WATER PUMP BIG
9	ECKG0175	WATER PUMP PULLEY, FAN TYPE - DRIVEN
10	ECMU0180	BELT RETAINER
11	HCBS0003	SHOULDER BOLT 6MM
12	ECKG0170	WATER PUMP BELT
13	ECKG0042	WATER PUMP PULLEY, CRANK
14	HCNS1001	NUT 10MM
15	HCBC0408	M4mm x 8 SOCKET HEAD black oxide
16	HCWF0401	4MM WASHER

Parts –
Engine –
Top End

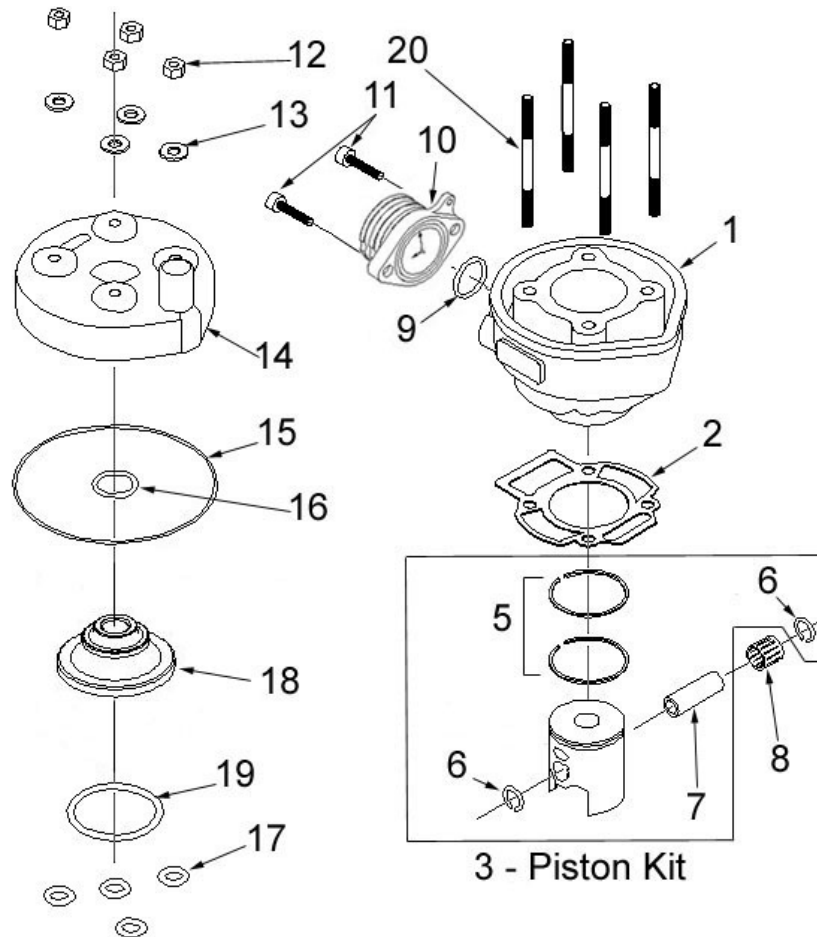

Engine – Top End		
REF #	PART #	DESCRIPTION
1	ECMU0129	CYLINDER KIT (INCLUDES PISTON, RINGS, PIN & CLIPS)
2	ZCKG0501	BASE GASKET 0.015" (0.4mm thick) For other Base Gaskets refer to Base Gasket Selection section of this manual
3	ECMU0060x	PISTON KIT ("x" denotes size, AB, A, C, etc.....)
5	ECMU0155	PISTON RINGS (2 PER SET)
6	ECMUSR00	SNAP RING FOR PISTON (2 REQ'D)
7	ECKG0012	WRIST PIN
8	ECMU0077	BEARING, WRIST PIN
9	ZCMUOR07	O-RING, EXHAUST FLANGE
10	ECMU0086	EXHAUST FLANGE
NOT SHOWN	ZCMOTE11	O-RINGS – PIPE TO FLANGE (2 REQ'D)
11	HCBC0612	M6X12, EXHAUST FLANGE SCREW (2 REQ'D)
12	HCNS0601	6mm Nut
13	HCWS1401	HARDENED WASHER
14	ECMU0530	CYLINDER HEAD OUTER
15	ZCMUOR02	O-RING, CYLINDER HEAD LARGE
16	ZCMUV024	O-RING CYLINDER HEAD SMALL
17	ZCMUOR10	O-RING CYLINDER STUD (4 REQ'D)
18	ECMU0532	CYLINDER HEAD, INSERT
19	ZCMUV032	O-RING CYLINDER HEAD MEDIUM
20	ECMU0075	STUD, CYLINDER 6mm
NOT SHOWN	ZAKGTE05	TOP END GASKET / O-RING KIT

Parts – Exhaust System

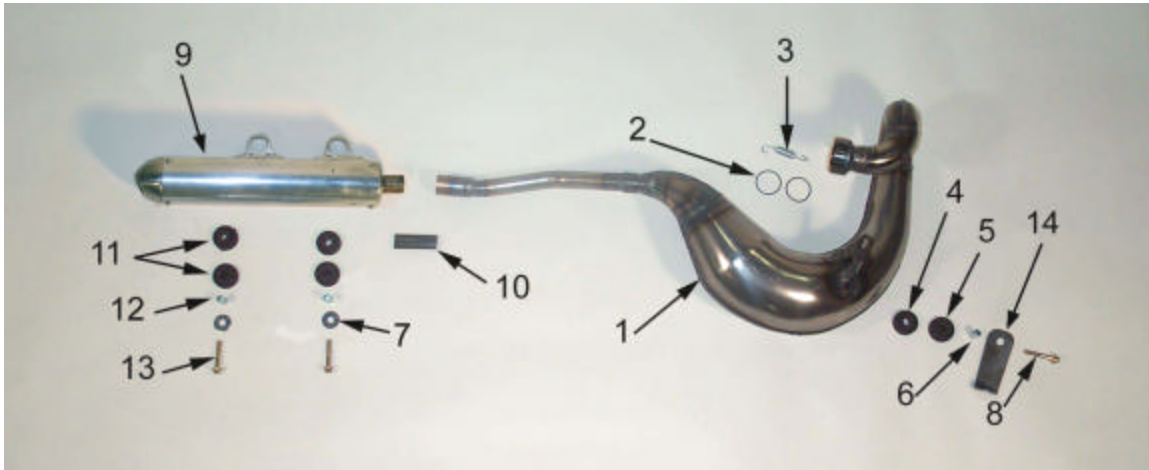

Exhaust System		
REF #	PART #	DESCRIPTION
1	XCCS2009	2009 KING EXHAUST PIPE
2	ZCMOTE11	HEADER PIPE O-RINGS (2 REQ'D)
3	XCMU0005	EXHAUST SPRING - SHORT
4*	MCMUGR02	PIPE GROMMET MALE (ONLY AVAILABLE IN MCMUGR02 GROMMET KIT)
5*	MCMUGR10	PIPE GROMMET FEMALE
6*	MCMUGR02	PIPE GROMMET SPACER (ONLY AVAILABLE IN MCMUGR02 GROMMET KIT)
7*	HCWF1478	PIPE GROMMET WASHER (2 REQ'D)
8*	HCBF0635	M6X35 FLANGE HEAD BOLT
	MCMUGR02	GROMMET KIT
NOT SHOWN	HCHA0003	6MM CLIP NUT – FOR FRONT PIPE MOUNT
9	XCMU0032	SILENCER
NOT SHOWN	XCMU0026	SILENCER PACKING KIT
NOT SHOWN	HCBB0408	M4 X 8 SILENCER SCREW
10	XCKG0009	PIPE / SILENCER SEAL
11	MCMUGR03	MOUNTING GROMMET (4 REQ'D TOTAL, 2 PER BOLT)
12	TCKG0001	SPACER (2 REQ'D)
13	HCBF0625	M6X25 FLANGE HEAD BOLT (2 REQ'D)
14	FCKG0028	BRACKET – RIGHT SIDE RADIATOR SHROUD
NOT SHOWN	HCHA0003	6MM CLIP NUT FOR PIPE MOUNTING
NOT SHOWN	HCCN0000	5MM CLIP NUT (ON SHROUD BRACKET)

*Parts are included in MCMUGR02 grommet kit.

Parts – Forks & Triple Clamps

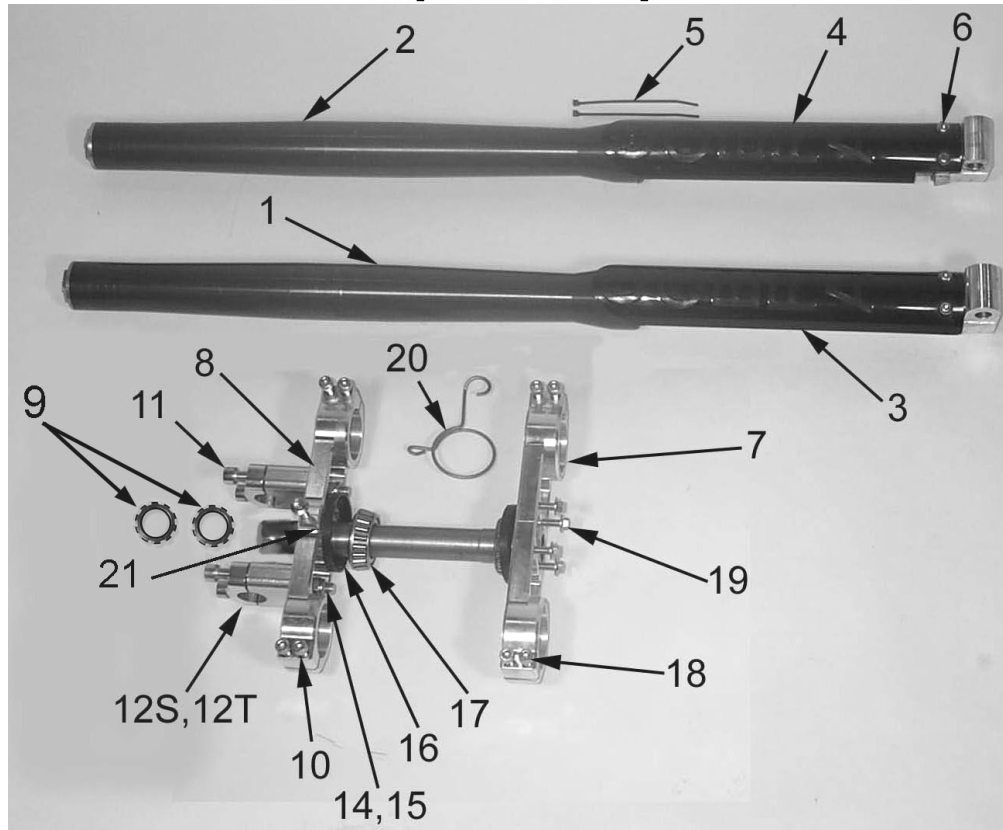

Front Forks and Triple Clamp		
REF #	PART #	DESCRIPTION
1	KAKG0020	FORK COMPLETE, NON-BRAKE SIDE
2	KAKG0021	FORK COMPLETE, BRAKE SIDE
3	KCKG0140	FORK GUARD SET
4	KCKG0140	FORK GUARD SET
5	MCMUZT04	CABLE TIE (2 REQ'D)
6	HCBB0612	M6X12, BUTTON HEAD SCREW (4 REQ'D)
7	FAKG0010	TRIPLE CLAMP BOTTOM ASSY, (1 BEARING AND DUST COVER)
8	FCKG0033	TRIPLE CLAMP UPPER
9	HCNJ0102	STEERING HEAD JAM NUT (2 REQ'D)
10	HCBC0625	SOCKET HEAD CS M6X25 (4 REQ'D)
11	HCBC0806	CAP SCREW M8X30 (4 REQ'D)
12S	TCMU0404	BAR MOUNT KIT, SHORT (2 REQ'D)
12T	TCMU0403	BAR MOUNT KIT, TALL (2 REQ'D)
14	HCBC1001	M10X45 SOCKET HEAD CAP SCREW (2 REQ'D PER BIKE)
15	HCNL1001	M10 LOCK NUT
NOT SHOWN	HCBH0816	M8 X 16 HEX HEAD BOLT
NOT SHOWN	HCWF0801	8MM FLAT WASHER
16	FCMU1103	DUST COVER (2 REQ'D)
17	FCMU0004	STEERING HEAD BEARING (2 REQ'D)
NOT SHOWN	FCMU0011	STEERING HEAD RACE (2 IN STEERING HEAD)
18	HCBC0625	SOCKET HEAD CS M6X25 (4 REQ'D)
19	HCBF0616	FENDER BOLT, M6X16 FLANGE HEAD (4 REQ'D)
20	FCKG0213	BRAKE LINE HOLDER
21	HCBF0620	M6X20 FLANGE HEAD BOLT (NUMBER PLATE FASTNR)

Parts – Forks – Leg Assembly

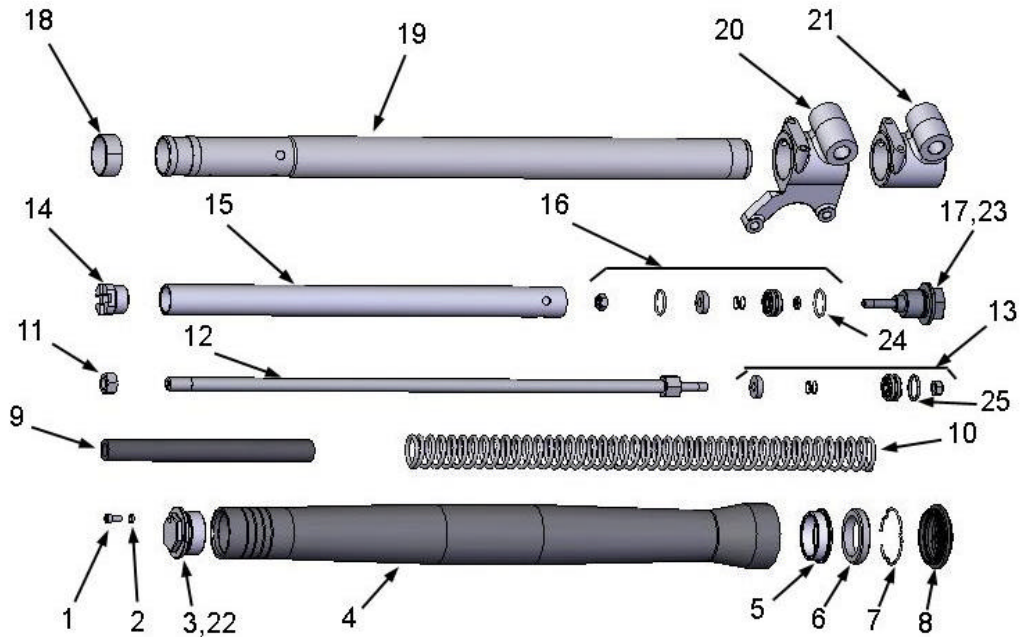

Fork Leg Assembly		
REF #	PART #	DESCRIPTION
1	HCBC0408	M4 X 8 SHCS (BLEED SCREW)
2	ZCKG0001	GASKET BLEED SCREW
3	KCKG0047	FORK CAP
4	KCKG0121	FORK LEG OUTER
5	KCKG0051	BUSHING FORK LEG
6	KCMU0007	FORK SEAL
7	KCKG0052	WIRE FORK ASSY RETAINING
8	KCKG0008	DUST COVER
9	KCKG0048	RUBBER CUSHION
10	KCKG1206	FORK SPRING
11	HCNJ0038	NUT – DAMPER ROD
12	KAKG0001	DAMPER ROD ASSEMBLY
13	KAKG0027	MID VALVE ASSEMBLY (STANDARD)
	KAKG0026	MID VALVE ASSEMBLY (LIGHT)
	KAKG0032	MID VALVE ASSEMBLY (HEAVY)
14	KCCCS0001	CARTRIDGE CAP
15	KCKG0054	DAMPER TUBE (CARTRIDGE) 5-star
16	KAKG0024	BASE VALVE ASSEMBLY (STANDARD)
	KAKG0023	BASE VALVE ASSEMBLY (LIGHT)
	KAKG0031	BASE VALVE ASSEMBLY (HEAVY)
17	KCKG0018	BOTTOM PLUG
18	KCKG0049	GLIDE RING
19,20	KAKG0144	FORK LEG INNER / BOTTOM BRAKE SIDE (not sold separately)
19,21	KAKG0145	FORK LEG INNER / BOTTOM NON-BRAKE SIDE (not sold separately)
22	ZCMUOR08	O-RING GASKET FORKCAP
23	ZCKGB017	O-RING BOTTOM PLUG
24	KCDC0005	O-RING BASE VALVE
25	KCDCSL01	SEAL BAND MID VALVE

Parts – Frame I

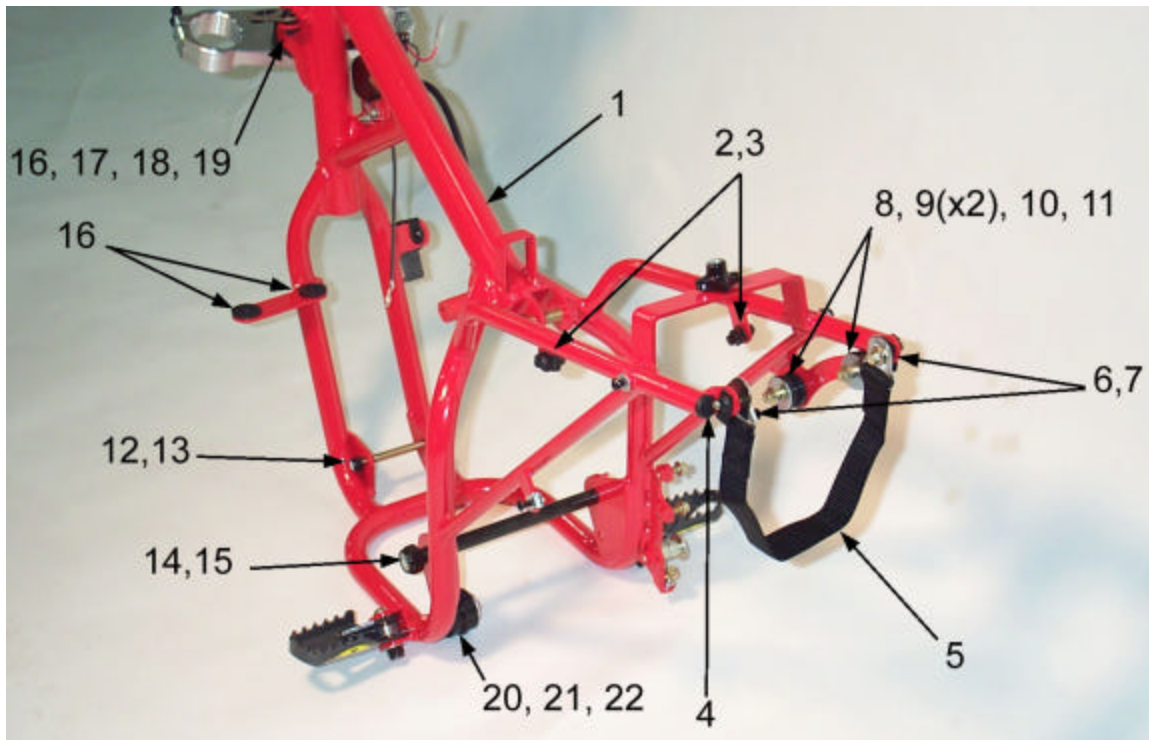

Frame		
REF #	PART #	DESCRIPTION
1	FACS2008	FRAME 2005-2009 KING/SR
2	HCBF0616	M6X16 FLANGE HEAD BOLT
3	HCHA0003	6MM "U" NUT
4	TCKG0007	PLUG – FRAME END
5	MCMU0003	STRAP – HANDLE
6	HCBF0620	M6X20 FLANGE HEAD BOLT
7	HCHA0003	6MM "U" NUT
8	HCBF0630	M6X30 FLANGE HEAD BOLT
9	MCMUGR03	GROMMET (2 REQ'D PER BOLT)
10	TCKG0001	ALUMINUM SPACER
11	HCWF1478	PIPE GROMMET WASHER
12	HCBH0880	FRONT ENGINE MOUNT BOLT, M8X30 SHCS
13	HCNL0801	8MM LOCKNUT
14	HCBH1403	SWINGARM PIVOT BOLT
15	HCNL1402	SWINGARM LOCK NUT (M14 X1)
16	MCMUGR03	GROMMET
17	HCBF0616	M6X16 FLANGE HEAD BOLT
18	FCMU0006	RADIATOR MOUNTING BRACKET (TEARDROP)
19	HCHA0003	6MM "U" NUT
20	FCMU0057	CHAIN ROLLER
21	HCWF1201	WASHER FLAT, CHAIN ROLLER (2 REQ'D)
22	HCCP0002	COTTERPIN 3/32 X 1 (2 REQ'D)

Parts – Frame II

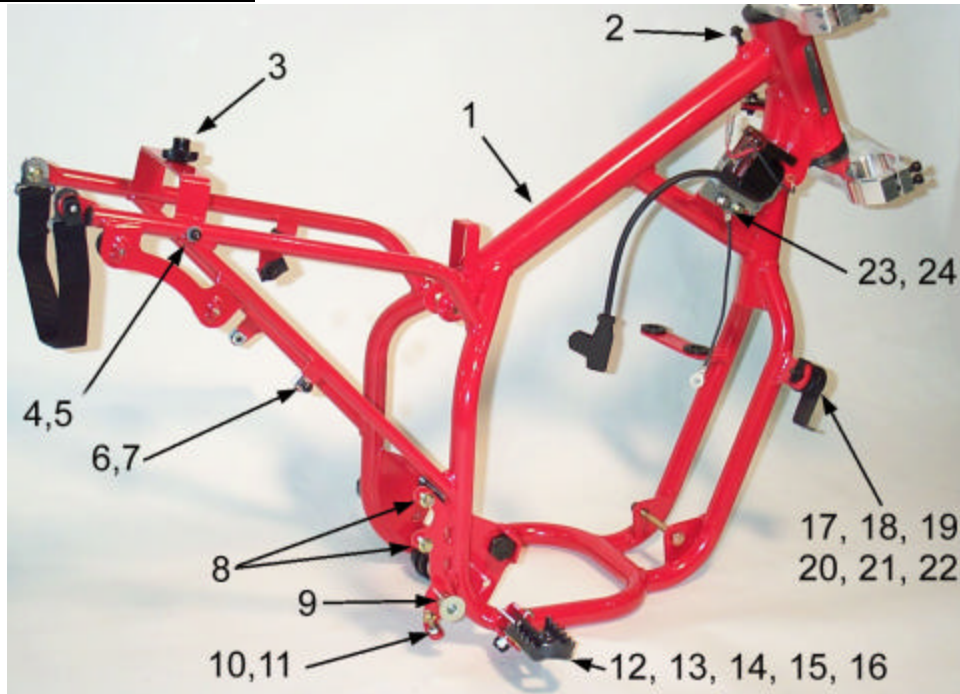

Frame		
REF #	PART #	DESCRIPTION
1	FAKG0011	FRAME 2005 CX50 SR
2	HCBF0616	M6X16 FLANGE HEAD BOLT
3	HCNK0001	KNOB – SEAT FASTENING
4	HCBB0516	M5X16 BUTTON HEAD BOLT
5	HCWP0002	ALUMINUM WASHER
6	HCBB0516	M5X16 BUTTON HEAD BOLT
7	HCCN0000	5 MM CLIPNUT
8	HCBF0620	M6X20 FLANGE HEAD BOLT
9	BCDC0009	BRAKE PIVOT BOLT
10	BCBH0602	M6 X 20 HEX HEAD BOLT
11	HCNS0601	6MM NUT
12	TCMU0010	WIDE FOOTPEGS (PAIR)
13	TCMU0106	FOOTPEG SPRING (SINGLE PIECE)
14	HCBH0840	M8 X 40MM FOOTPEG BOLT
15	HCWF0801	8MM FLAT WASHER
16	HCNL0801	8MM LOCKNUT
17*	MCMUGR02	PIPE GROMMET MALE (ONLY AVAILABLE IN MCMUGR02 GROMMET KIT)
18*	MCMUGR10	PIPE GROMMET FEMALE
19*	MCMUGR02	PIPE GROMMET SPACER (ONLY AVAILABLE IN MCMUGR02 GROMMET KIT)
20*	HCWF1478	PIPE GROMMET WASHER (2 REQ'D)
21*	HCBF0635	M6X35 FLANGE HEAD BOLT
	MCMUGR02	GROMMET KIT
22	HCHA0003	6MM “U” NUT
23	HCBH0502	M5X16 HEX HEAD BOLT
24	HCCN0000	5 MM CLIPNUT
25	HCWF0601	6MM FLAT WASHER (ONLY 1 USED)

*Parts are included in MCMUGR02 grommet kit.

Parts – Front Brakes

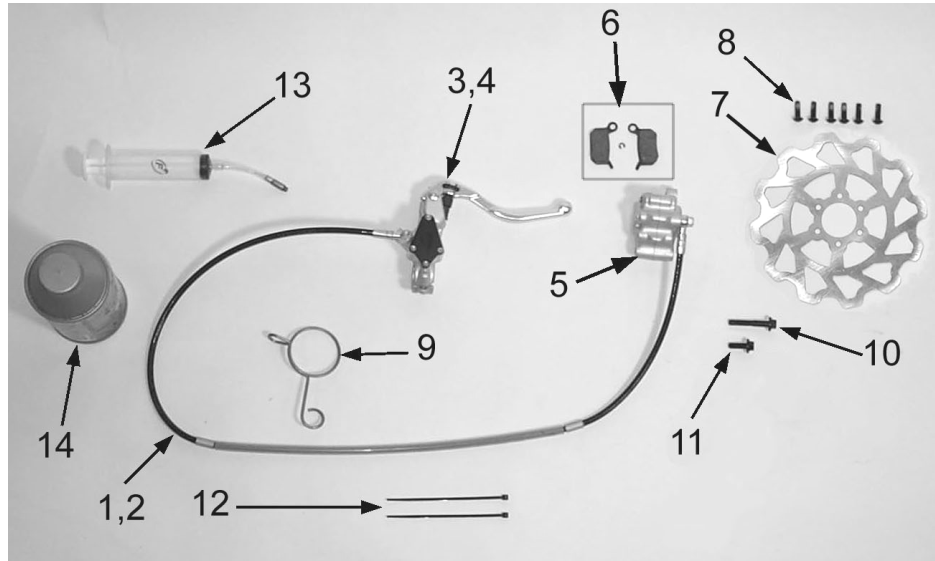

Front Brakes		
REF#	PART #	DESCRIPTION
1	BAKG0003	FRONT BRAKE ASSEMBLY
2	BCKG0030	HOSE – BRAKE FRONT
3	BCKG0023	ALLOY BRAKE LEVER
4	BCKG0024	BRAKE PERCH & MASTER CYLINDER ASSY W/ LEVER
5	BCKG0029	CALIPER – FRONT
6	BKKG0001	BRAKE PADS, WITH “E” CLIP
7	BCMU0503	BRAKE ROTOR
8	HCBC0501	M5X12 SHCS (6 REQ'D)
9	FCKG0213	GUIDE – FRONT BRAKE LINE
10	HCBF0635	M6 X 35 FLANGE HEAD BOLT updated these for new fork bottoms
11	HCBF0616	M6 X 16 FLANGE HEAD BOLT
12	WCMUZT04	CABLE TIES (2 REQ'D) TO SECURE BRAKE LINE TO FORK GUARD
13	BCKG0031	BLEED KIT (MULTIPLE SYRINGES, FITTINGS & HOSE)
14		BRAKE FLUID ** DOT 4 ONLY**
ACCESSORY	BCKG0028	LEVER ADJUSTMENT KIT
ACCESSORY	BCKG0027	RESERVOIR SEAL KIT
ACCESSORY	BCKG0025	REPLACEMENT BAR CLAMP AND SCREWS (FOR MASTER CYLINDER)
ACCESSORY	BCKG0026	PISTON & REBUILD KIT FOR MASTER CYLINDER
ACCESSORY	BCKG0017	CALIPER ORING & BOLTS (F&R)
ACCESSORY	BCKG0018	CALIPER PISTON KIT (F&R)
ACCESSORY	BCKG0019	RETURN SPRING (4 FINGER SPRING)
ACCESSORY	ZCMUOR09	O’RING - BANJO FITTING

Parts – Front Wheel

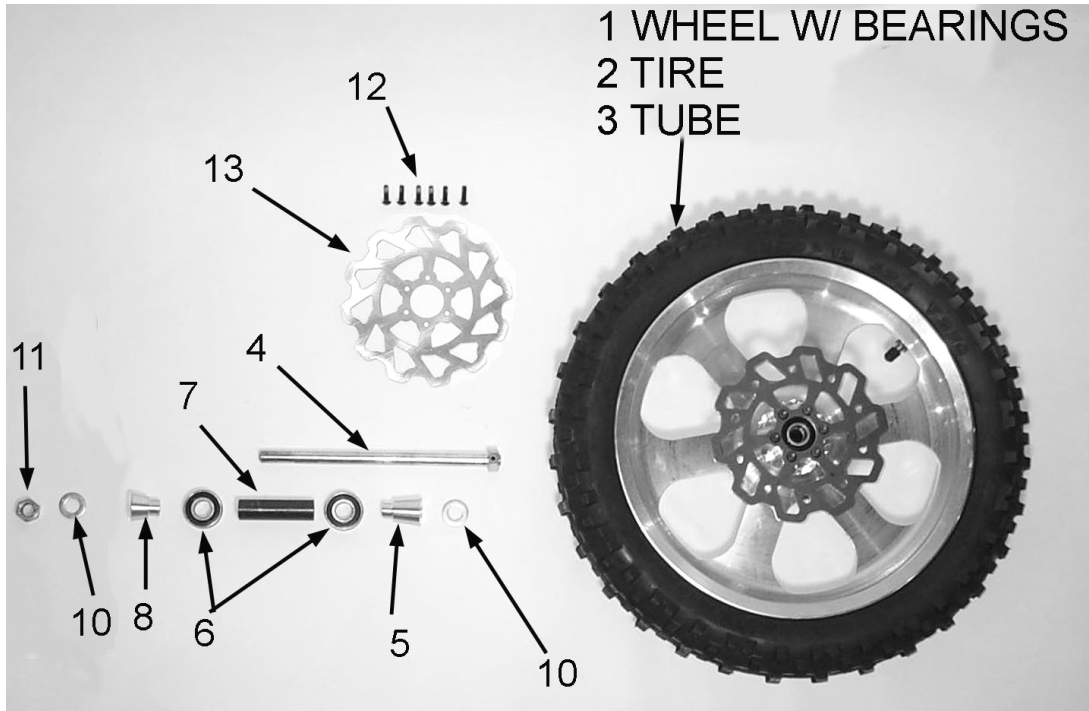

Front Wheel		
REF #	PART #	DESCRIPTION
1	WAKG0022	FRONT WHEEL W BEARINGS
2	WCKG1200B	12" X 2.50 FRONT TIRE BRIDGESTONE
	WCKG1200D	12" X 2.50 FRONT TIRE DUNLOP
	WCKG1200V	12" X 2.50 FRONT TIRE VEE RUBBER
3	WCKG1201	12" FRONT TUBE
4	WCKG0011	FRONT AXLE
5	WCMU0123	FRONT WHEEL SPACER, X LARGE
6	WCMU0120	WHEEL BEARING (2 REQD)
7	WCMU0032	WHEEL BEARING SPACER
8	WCMU0101	FRONT WHEEL SPACER, LARGE
10	HCWF1202	FRONT AXLE WASHER
11	HCNS1201	FRONT AXLE NUT (12MM)
12	HCBC0501	BRAKE ROTOR MOUNTING BOLTS (6 REQD)
13	BCMU0503	BRAKE ROTOR

Parts – Plastic Bodywork & Seat

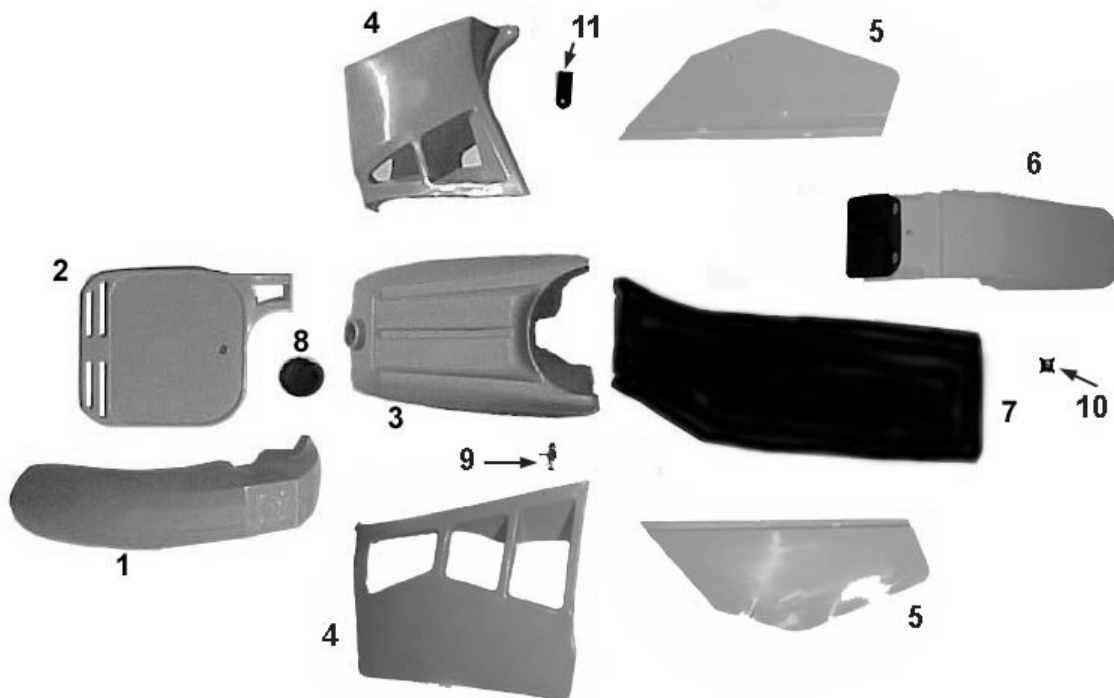

Plastic and Seat		
REF #	PART #	DESCRIPTION
1	TCMU0016	FRONT FENDER
NOT SHOWN	HCBF0616	FRONT FENDER MTG BOLTS (4 REQD)
2	TCMU0005	FRONT NUMBER PLATE
NOT SHOWN	HCBF0625	FRONT NUMBER PLATE MTG BOLT
3	TCMU0006	FUEL TANK (NO PETCOCK OR CAP)
NOT SHOWN	HCBF0616	FUEL TANK MOUNTING BOLT
4	TCMU1203	RADIATOR SHROUDS (RAD CAP ACCESS)
NOT SHOWN	HCBB0402	RAD SHROUD TO TANK BOLT, LONG (1 PER SIDE)
NOT SHOWN	HCBB0403	RAD SHROUD TO TANK BOLT, SHORT (1 PER SIDE)
NOT SHOWN	HCBB0516	M5X16 RAD SHROUD MOUNT BOLT (1 PER SIDE)
NOT SHOWN	HCWP0002	SHROUD WASHER (1 PER SIDE)
5	TCMU0113	SIDE NUMBER PLATE SET
NOT SHOWN	HCBB0516	M5X16 NUMBER PLATE MTG SCREW (2 PER SIDE)
NOT SHOWN	HCWP0002	NUMBER PLATE WASHER (UPPER HOLE ONLY)
6	TAMU0001	REAR FENDER ASSEMBLY
NOT SHOWN	HCBH0620	REAR FENDER MTG BOLT (2 REQD)
7	TCMU0505	SEAT
8	TCMU0103	FUEL TANK CAP
9	TCMU0000	FUEL PETCOCK (06 LEVER)
10	HCKN0001	KNOB – SEAT FASTENING
11	FCKG0028	BRACKET – RIGHT SIDE RAD SHROUD
NOT SHOWN	HCCN0000	5MM CLIP NUT
NOT SHOWN	HCBB0516	M5X16 RAD SHROUD MOUNT BOLT (1 PER SIDE)
NOT SHOWN	TCCS2008	GRAPHIC KIT – CX50 SR 2008
12	MCMU0003	STRAP HANDLE
NOT SHOWN	FCKG0001	LOUVER
NOT SHOWN	HCCN0000	5MM CLIPNUT
NOT SHOWN	HKPP0001	PUSH PINS – 10 PACK SHROUD FASTENING

Parts – Rear Brake

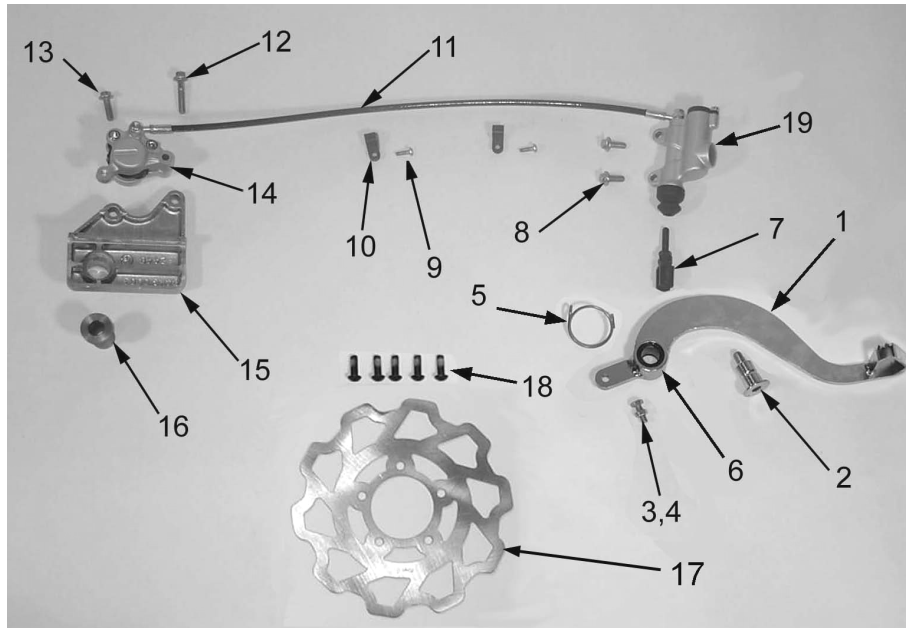

Rear Brake System		
REF #	PART #	DESCRIPTION
	BAKG0002	BRAKE COMPLETE
1	BCMU0012	BRAKE PEDAL
2	BCDC0009	BRAKE PIVOT BOLT
3	HCBH0620	M6X20 HEX HEAD BOLT
4	HCNS0601	6 MM NUT
5	BCMUSP02	BRAKE RETURN SPRING
6	BCMU0501	SEAL – BRAKE PEDAL (2 REQ'D)
7	BCDC0004	PUSH ROD, REAR BRAKE
8	HCBF0620	M6X20 FLANGE HEAD BOLT (2 REQ'D)
9	HCPP0832	BRAKE HOSE CLAMP FASTENER (2 REQ'D)
10A	HCCC0000	BRAKE HOSE CLAMP (2 REQ'D) for hose with clear cover
10B	HCCC0006	BRAKE HOSE CLAMP (2 REQ'D) for hose with black cover
11	BCKG0010	REPLACEMENT BRAKE HOSE
12	HCBF0635	M6X35 FLANGE HEAD BOLT
13	HCBF0620	M6X20 FLANGE HEAD BOLT
14	BCKG0013	CALIPER – REAR BRAKE
15	BCKG0103	BRAKE CARRIER WITH PAD
16	BCKG0006	WHEEL SPACER - FLOATING CARRIER
17	BCMU0502	BRAKE ROTOR
18	HCBC0601	M6X16 SOCKET HEAD CAP SCREWS (5 REQ'D)
ACCESSORY	BKKG0001	BRAKE PADS WITH “E” CLIP
ACCESSORY	BCKG0031	BLEED KIT (MULTIPLE SYRINGES, FITTINGS & HOSE)
ACCESSORY	BCKG0014	FITTING KIT
ACCESSORY	BCKG0015	MASTER CYLINDER PISTON / SEAL KIT
ACCESSORY	BCKG0016	RESERVOIR SEAL KIT
ACCESSORY	BCKG0017	CALIPER BOLT / O-RING KIT
ACCESSORY	BCKG0018	CALIPER PISTON / SEAL KIT
ACCESSORY	BCKG0019	PAD RETURN SPRING (4 LEG SPRING)
ACCESSORY	ZCMUOR09	O’RING - BANJO FITTING

Parts – Rear Wheel

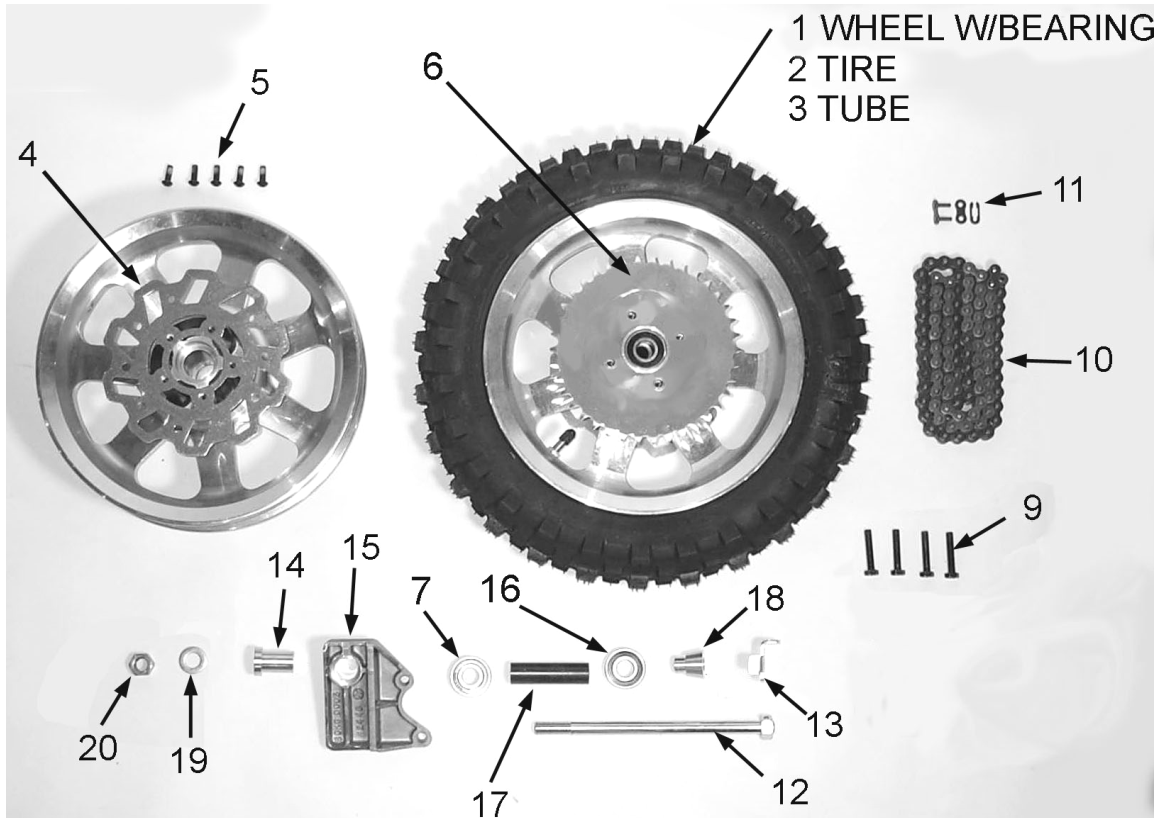

Rear Wheel		
REF #	PART #	DESCRIPTION
1	WAKG2007R	REAR WHEEL W/BEARINGS
2	WCMU1075B	TIRE – REAR 10X2.75" BRIDGESTONE
	WCMU1075D	TIRE – REAR 10X2.75" DUNLOP
	WCMU1075V	TIRE – REAR 10X2.75" VEE RUBBER
3	WCMUTU10	TUBE, 10"
4	BCMU0502	BRAKE ROTOR
5	HCBC1616	M6X16 SOCKET HEAD CAP SCREWS (5 REQ'D)
6	PCMU0138	38T REAR SPROCKET (NO DAMPERS)
7	WCMU0020	WHEEL BEARING BRAKE SIDE
9	HCBH0702	M7X30 HEX HEAD BOLT
10	PCMU0100	CHAIN 420 X 100
11	PCMU0001	MASTER LINK 420
12	WCMU0016	REAR AXLE
13	HCPA0002	AXLE HEAD FIXING PLATE
14	BCKG0006	WHEEL SPACER - FLOATING CARRIER
15	BCKG0103	BRAKE CARRIER
NOT SHOWN	BCKG0104	BRAKE CARRIER PAD
16	WCMU0120	WHEEL BEARING SPROCKET SIDE
17	WCMU0034	WHEEL BEARING SPACER
18	WCMU0101	WHEEL SPACER
19	HCWF1202	AXLE WASHER
20	HCNL1201	AXLE NUT 12MM

Parts – Shock

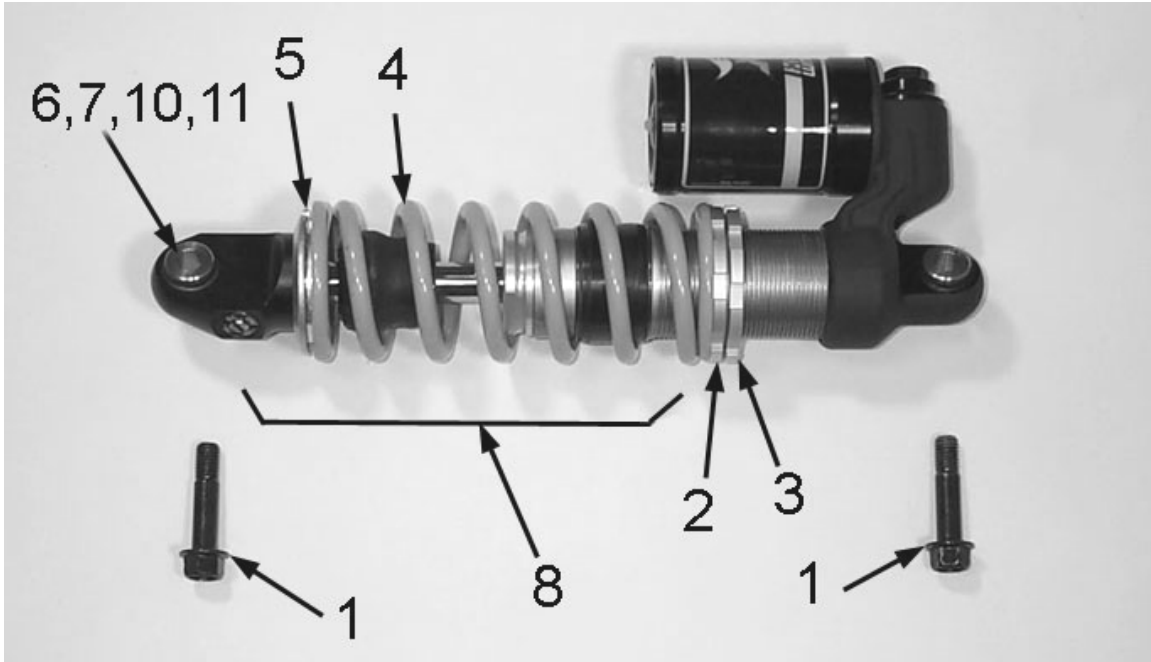

Shock		
REF #	PART #	DESCRIPTION
	SAKG2006	SHOCK ABSORBER
1	HCBF1040	M10 X 40 HEX HEAD BOLT
2	SCKGFX04	PRELOAD RING BOTTOM
3	SCKGFX05	PRELOAD RING TOP (LOCK RING)
4	SCKGFX37	SHOCK SPRING 3.7 KG/MM (STANDARD)
	SCKGFX35	SHOCK SPRING 3.5 KG/MM (LIGHT)
	SCKGFX39	SHOCK SPRING 3.9 KG/MM (HEAVY)
5	SCKGFX03	SPRING RETAINER BOTTOM
6	SCKGFX01	COLLAR - SHOCK END MOUNT (WIDTH REDUCER)
7	ZCMU0114	O-RING - SHOCK END MOUNT
8	SAKG2006	REAR SHOCK (FOX)
10	SCKGFX06	BEARING - SPHERICAL SHOCK MOUNT
11	SCKGFX07	RETAINING RING SHOCK END BEARING

Parts – Swingarm Assembly

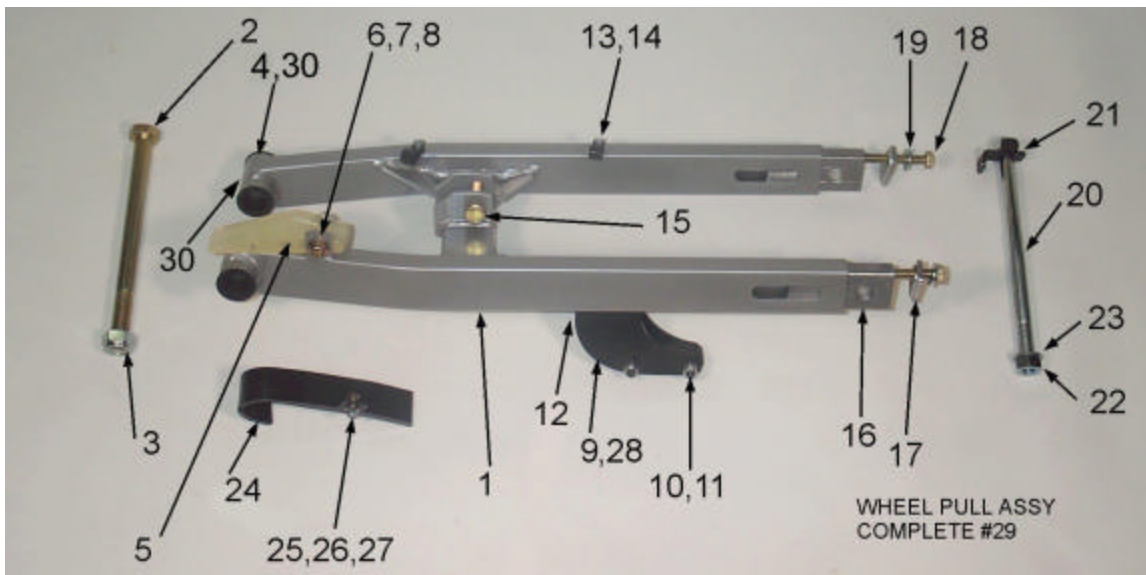

Swingarm		
REF #	PART #	DESCRIPTION
1	GAKG0002	SWINGARM PAINTED
2	HCBF1403	SWINGARM PIVOT BOLT
3	HCNL1402	SWINGARM LOCK NUT (M14 X1)
NOT SHOWN	HCWF1400	14MM FLAT WASHER
4	GCMU0001	SWINGARM BUSHING (4 PER)
5	GCMU0005	TOP SWINGARM GUARD (CHAIN SLIDER)
6	HCBB0803	M8X40 BUTTON HEAD BOLT
7	HCWF5601	FLAT WASHER
8	HCNL0801	8MM LOCK NUT
9	PAKG0001	CHAIN GUIDE ASSEMBLY COMPLETE
10	HCBFT640	6X40 FLAT HEAD SCREW (2 REQ'D)
11	HCNL0601	6MM LOCKNUT (2 REQ'D)
12	HCBF0620	M6 X 20 FLANGE HEAD BOLT (2 PER)
13A	HCCC0000	BRAKE HOSE CLAMP (2 REQ'D) for hose with clear cover
13B	HCCC0006	BRAKE HOSE CLAMP (2 REQ'D) for hose with black cover
14	HCPP0832	BRAKE HOSE CLAMP FASTNER (2 PER)
15	HCBF1040	M10 X 40 LOWER SHOCK MOUNT BOLT
16	FCMU0203	WHEEL PULL
17	FKMU0005	WHEEL PULL ENDCAP WITH WASHER
18	HCBH0810	WHEEL PULL BOLT M8X65
19	HCWF801	WHEEL PULL WASHER (M8)
NOT SHOWN	FAMU0005	WHEEL PULL ASSEMBLY (BLOCK, CAP, BOLT AND WASHER)
20	WCMU0016	REAR AXLE
21	HCPA0002	AXLE HEAD FIXING PLATE
22	HCNL1201	AXLE NUT, 12 MM
23	HCWF1202	AXLE WASHER
24	GCMU0017	OPTIONAL TOP CHAIN SLIDE
25	HCFH0516	FLAT HEAD SCREW
26	HCWF0501	WASHER
27	HCNL0501	LOCK NUT
28	PCKG0004	BOTTOM CHAIN SLIDER
29	FAMU0005	WHEEL PULL ASSEMBLY COMPLETE
30	GCKG0008	SWINGARM PIVOT TUBE SPACER (2 REQ'D)

Service

Trained technicians with precision gauging and proper assembly fixtures carefully assemble all Cobra engines to specific tolerances. If you feel you have the skills, and the appropriate tools, to perform the following service tasks please follow the instructions closely. The part numbers are listed throughout to help you when ordering parts from your local Cobra dealer.

If you don't feel comfortable with the service work, log on to www.cobramotorcycle.com to find a Cobra dealer or Call 517 437 9100.

Engine Service

One method for determining whether the top end of your engine needs rebuilt is to perform a WOT (Wide Open Throttle) kicking compression test. Before performing the procedure please read the caution notes below.

CAUTION:

- There appears to be a wide range of variability in reading compression gauges across the country.
- The head volume of this Cobra Motorcycle is very small and so requires many kicks ~20 before you establish the most accurate reading possible.
- Because of the geometry of the spark plug used in this Cobra Motorcycle, the adapter used with your compression tester must have a similar volume protruding into the combustion chamber to establish an accurate value.
- Length of hose on the compression tester will affect the reading. The shorter the hose length the more accurate your reading will be.

Because of these difficulties in measuring an *absolute* compression value, a useful *relative* value can be achieved by testing your bike's compression with your own particular gauge after a new top end or when the bike is new so that you know what your particular gauge reads on a 'fresh' engine. When it has dropped to 90% of its original value the engine will be down on power and would benefit from a rebuild. When it's dropped to 80% it really needs rebuilt! Using the table below will help you determine monitor the condition of your top end.

	Engine is Fresh Measured Value	Engine Down on Power Measured Value * 0.9	Engine NEEDS Rebuilt Measured Value * 0.8
Example	110 psi	110 psi * 0.9 = 99 psi	110 psi * 0.8 = 88 psi
Your Values			

Procedure for Compression Testing

1. Shut off the fuel petcock.
2. Install the compression gauge into the spark plug hole.
3. Hold the throttle to wide open, and kick repeatedly (approximately 20 times) or until the gauge reading does not increase in value with each kick.

Base Gasket Selection

Tools required

- 17mm wrench
- 1mm flexible solder material
- measurement calipers

When rebuilding the 'top end' of your Cobra motorcycle, care must be taken to ensure the proper squish clearance. Squish clearance is defined as the minimum distance between cylinder head and piston at TDC, and there are negative effects of either having too much or too little clearance. Since parts like the crank, connecting rod, cylinder head, piston, and crankcases all have varying tolerances, Cobra offers several different base gasket thickness' to ensure that you can always set the squish clearance of your engine to factory specifications.

For base gasket replacement use the code (see figure 21 for location) along with the table on the following page reorder the correct thickness gasket.

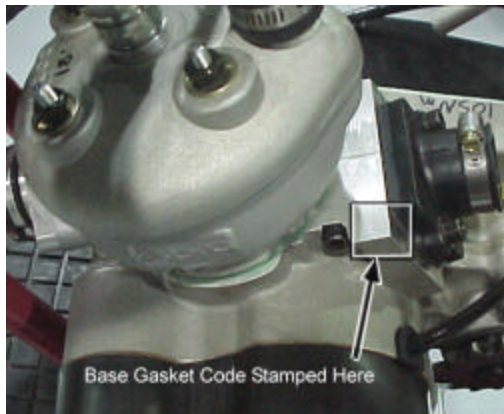

Figure 21

Code	Supplied Base Gasket Thickness		Cobra #
#	mm	inch	Part #
2	0.2	0.008	ZCMU0702
	0.25	0.010	ZCMU0011
3	0.3	0.012	ZCMU0703
4	0.4	0.015	ZCKG0501
5	0.5	0.020	ZCMU0705
6	0.6	0.024	ZCMU0706
7	0.7	0.028	ZCMU0707
8	0.8	0.031	ZCMU0708

NOTE

Tolerances will affect the actual gasket thicknesses.

If during the course of the maintenance more parts than the base gasket are changed, the squish clearance should be measured, and possibly a different base gasket will be required.

The easiest way to measure squish clearance is with 1mm to 1.5mm thick flexible solder wire (available through most popular electronic stores). The process is as follows:

- Assemble the top end of the engine with either; 1) the crankcase stamp recommended base gasket or, 2) if assembling with a new set of cases assemble with a 0.4mm (0.015") base gasket, and torque the head nuts to the proper torque specifications leaving off the spark plug and ignition cover (piston rings can be left off to ease assembly).
- Carefully insert the solder wire through the spark plug hole, into the cylinder far enough such that the tip of the wire touches the left or right side cylinder wall (not the front or back as the piston will rock more and give incorrect measurement).
- Hold the wire at this position and rotate the crankshaft, by the flywheel nut (or kick lever) three revolutions to 'smush' the solder wire.

CAUTION:

If you rotate the flywheel nut in a counterclockwise direction there is a risk of loosening the nut.

- Pull out the wire and measure the solder thickness at the thinnest location near its tip accurately with the thin tips of calipers.
- Adjust base gasket thickness as necessary to get the desired value .

Upon completion, your final assembly squish clearance should agree with the chart below

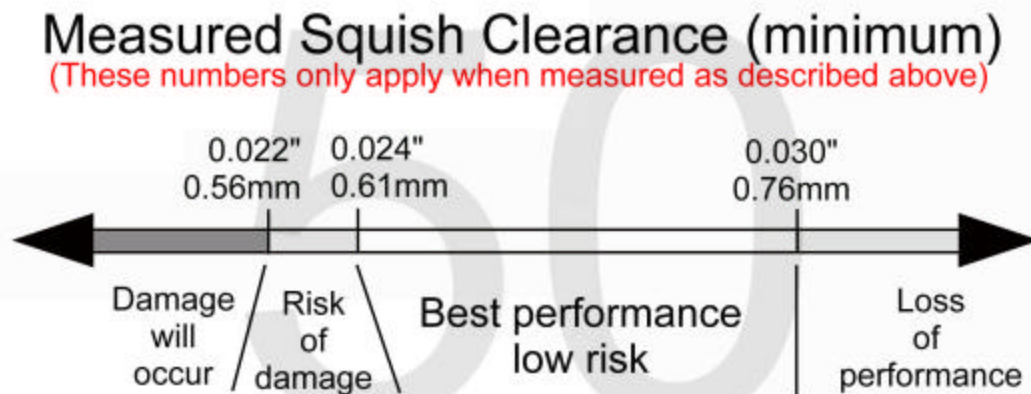

Engine Removal

To service the bottom end and transmission, the engine must be removed from the frame.

Tools required

- 10, 11, 13, 22 mm wrench
- 8, 10, 14, 17 & 19 mm sockets
- 3, 4 & 5 mm hex key (Allen wrench)
- 7 mm nut driver, flat or Phillip, screwdriver for hose clamps
- Spring remover
- Flywheel / clutch puller (#MCMUTL68)
- Clutch nut removal tool (Call local dealer for details).

Procedure

1. Remove the seat.
2. Turn of the fuel at the petcock and disconnect the fuel line.
3. Remove the tank (8 mm socket).
4. Remove the carburetor from the inlet (flat head or Phillips head screwdriver, 7 mm nut driver).
5. Remove the silencer & pipe (spring remover, 8mm socket).
6. Locate a suitable container for the engine coolant and disconnect the coolant lines connected to the engine (8 mm socket).

NOTE:

If the coolant looks to be free of contaminates it may be reused.

7. Remove the master link from the chain.
8. Remove front engine mount bolt (13 mm socket, 6 mm hex key).
9. Remove the swingarm bolt (22mm socket).

NOTE:

Only drive the swingarm bolt far enough to clear the engine, leave it holding the one side of the swingarm to the frame

10. Remove the engine from the right side of the frame.

NOTE:

If you are merely performing a top end service skip ahead to *Top End Disassembly Procedure*.

Complete Engine Disassembly Procedure

1. Remove the magneto cover (4mm hex key)
2. Remove the bolt from the water pump shaft (4mm) and slide off the belt cover and the water pump belt

3. Using a flywheel holding tool and 14 mm socket remove the nut that secures the flywheel.
4. Using the Cobra flywheel / clutch puller (#MCMUTL68), remove the flywheel from the crankshaft.
5. Remove the stator (4mm hex key).
6. Remove the left hand thread blue nut holding the CFD to the transmission input shaft (19 mm socket).
7. Remove the special nut / starter gear that holds on the clutch (special tool available, contact your local dealer).
8. With the Cobra flywheel / clutch puller (#MCMUTL68), remove the clutch from the crankshaft (details in Clutch Service portion of this manual).

Top End Disassembly Procedure

1. Remove the cylinder head nuts (10mm).
2. Remove the cylinder head outer.

INSPECTION NOTE:

Inspect the cylinder head for deposits and abrasions.

1. If there are deposits they should be removed
 - a. Black oily deposits (indicating a rich mixture or improper oil type/quantity) can be removed with solvent
 - b. Crusty deposits (indicating dirt ingestion) can be removed with solvent and may require some scraping.
2. Abrasions
 - a. Pitting or erosion indicates detonation and may require cylinder head replacement, also
 - i. Retard the ignition timing
 - ii. Use a higher octane fuel
 - b. Missing chunks or indentations indicate broken hardware or ingested items - replace the cylinder head.

3. Remove the cylinder head insert.
4. Remove the cylinder.

INSPECTION NOTE:

Inspect the cylinder bore for abrasions, deposits, and missing coating.

1. If abrasions: scrapes, scratches, pitting, etc... are found, replace the cylinder.
2. If deposits are all are found
 - a. Clean with muratic acid.
 - b. Once the deposits are removed, inspect for abrasions and missing surface coating.
 - i. If there are abrasions or missing coating, replace.
 - ii. If all looks well, the cylinder may be saved.

- 5.

⚠ WARNING

Muratic acid can be dangerous. Follow the manufacturers instructions closely.

6. Remove the piston clip with a scribe.
7. Remove the piston pin with a piston pin remover.

INSPECTION NOTE:

Inspect the piston for abrasions and deposits on the top and sides and clean or replace as necessary.

INSPECTION NOTE:

Piston ring end gap should be between 0.008" (0.2 mm) and 0.020" (0.5 mm)

Splitting the Cases

1. Remove the fasteners holding the two halves of the crankcase together.
2. Separate the cases with a proper case splitting tool.

CAUTION:

Take caution when handling the crankshaft. It is the main power transfer to the rest of the engine. If it is out of alignment, it will cause premature failure of your bearings which can lead to serious damage to the cylinder as well as the rest of the engine. Do not try to true the crank yourself. Truing the crank should be done professionally.

CAUTION:

- If you split the cases, check the gear tooth faces for chipping & signs of fatigue.
- Check the small needle bearings for fatigue. If the bearings are damaged, the engine cases should be checked to make sure the needle-bearing casing didn't oblong the bearing hole in the case.
- Needle bearings should be replaced every couple months of hard racing.

Engine assembly

CAUTION:

For any seals that are to be installed, apply a light amount of grease to the seals' ID, assembly lube on all bearings and a small amount of Loctite to the OD.

1. Press the three bearings into the respective holes in each case half.
2. Press in the crank seals such that the concave side faces the crank weights.
3. Press in the counter shaft seal (concave side faces inside of transmission)
4. Install the water pump assembly wire ring retainer
5. Press in the water pump assembly
6. Tap both ways axially then verify easy rotation.
7. Inspect the crankshaft for proper true geometry (no more than 0.002 ", 0.05mm, measured at bearing journal area while supported from the ends).

CAUTION:

Insert a 7.05mm (0.278") shim between the crank throws before pressing on the crank.

8. Insert the case screws with the proper lengths at locations shown.

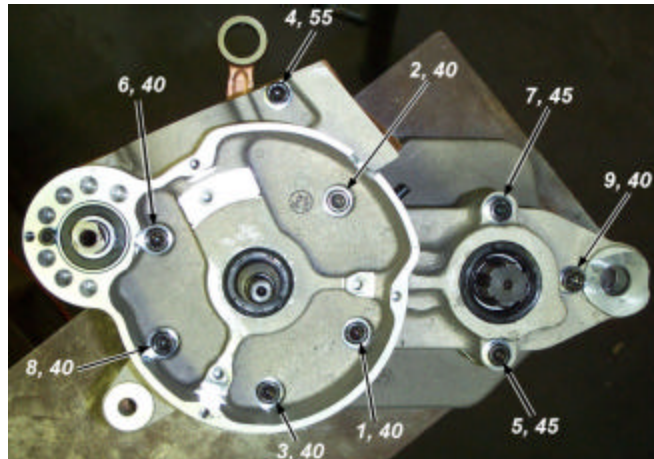

Figure 28

9. Torque to 12 Nm (105 in-lb) in the pattern shown in figure 28.
10. Trim away any excess gasket material if necessary.

NOTE: Check engine mount holes for excess material that may cause problems in engine installation.

11. Install the piston with new wrist pin bearing and, pin and clips.

CAUTION:

Be sure to install the piston such that the arrow on the top piston surface points to the exhaust (front of bike/engine) and put assembly lube on the connecting rod bearing.

12. Install the piston rings.

CAUTION:

Ring end gap should be no less than 0.25 mm (0.010") and no more than 0.64mm (0.025")

13. Install the base gasket.

CAUTION:

See base gasket selection at the beginning of service section.

14. Install the cylinder being sure that the piston rings are properly aligned with the indexing pins.

CAUTION:

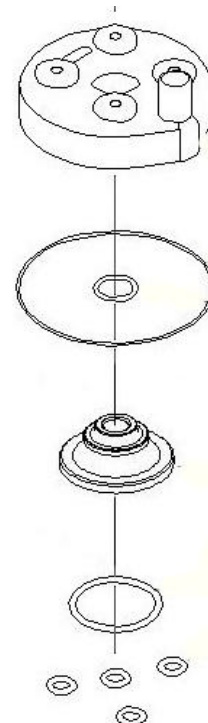

Never force the cylinder. If resistance is felt, determine the problem and solve it. Once installed slightly rotate the cylinder back and forth insuring that the rings are properly seated.

15. Install cylinder head insert.

Figure 29

NOTE: A light application of silicone grease can help hold the O-rings into position during assembly.

16. Install O-RINGS as shown in figure 29.
17. Install the cylinder head.
18. Install the washers (with flat side down) and nuts. Torque to 105 in-lb (12 Nm)
19. Install reed and inlet manifold with new gasket (105 in-lb, 12 Nm).
20. Leak check the engine to 20 psi to ensure proper seal.
21. Install stator reinstalling the grommet and wires (snug the bolts).
22. Install the rotor per *Rotor Installation* section, under the *S3: Ignition* portion of this manual.
23. Install the water pump outlet pipe (apply Ultra black Hi-Temp RTV silicon gasket maker to the threads before assembly) before installing the clutch and rotate to a vertical position with the engine resting on a bench
24. Install the CFD.
25. Install the clutch per *Clutch Installation* section in this manual.
26. Install the coolant drain plug with copper washer (11 ft-lb, 15 Nm).
27. Make sure that the exhaust spacer is on the cylinder (53 in-lb, 6 Nm).
28. Install the spark plug with a fresh gasket (to apply the proper torque to the spark plug when inserting, one must first screw the spark plug in until the metal gasket ring causes resistance and then turn another 1/8 to 1/4 turn).

Clutch

CAUTION:

The clutch components (arbor, shoes, bolt, and belleville washers) on your 2008 Cobra are similar looking but different in geometry from prior years. Do not mix old and new parts as damage will occur.

Cobra clutch puller assembly:

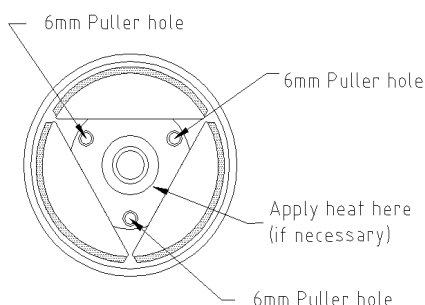

Figure 30

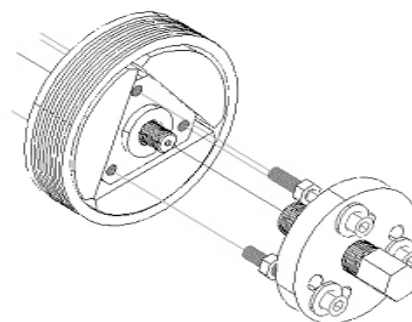

Figure 31 Clutch puller installation

Tools recommended for clutch service:

- Universal clutch puller- a universal puller that pulls the clutch, main drive gear and rotor. (Part # MCMUTL70).
- 5mm T-handle
- Clutch nut removal tool (ECMU0078) & spanner wrench (ECMU0082).
- *Cobra 3 Shoe Clutch Milk* (Part # MCMUGF01).

CLUTCH REMOVAL:

1. Drain the engine transmission oil and remove the clutch cover.
2. Remove the clutch nut (not left hand thread) on the end of the crankshaft with the clutch nut removal tool.
3. Attach the Universal Puller. There are three 6mm clutch puller holes located on the ends of the center hub. (figures 30 & 31)

CAUTION:

Do not use a jaw type puller or use the 6mm tapped holes as jackscrews or you are likely damage the clutch or drum.

4. If necessary apply heat to the center clutch hub.

CAUTION:

Do not heat the crankshaft threads or the aluminum shoes.

5. Keep tension on the puller as you are heating it.

⚠ WARNING

The clutch will often pop off under tension from the puller and it will be very hot.

CLUTCH WASHER STACKUPS:

Once the clutch is removed, and cool to touch, carefully put it into a vice and remove the center shoulder bolt out of each clutch shoe. You will probably have to heat the center hub again to remove the bolts. Once you get a bolt loosened, carefully remove it with the shoe and observe the way the spring washers are stacked. Clean the washers and bolt if you intend to reuse.

The spring stacks in your Cobra clutch will contain 11 individual springs and flat washer(s) configured as a 5 ½ stack. See figure 32. This clutch is designed such that it reconfigured by the customer to achieve different clutch engagements 'hits' by changing washer counts and configurations.

CAUTION:

Generally reassemble the springs as you removed them from the engine or as you received them from Cobra. If you are unsure call the Cobra Technical Support Group 517 437 9100 #4, and consult the experts.

CLUTCH ASSEMBLY REFERENCE DRAWING		
REF #	PART #	DESCRIPTION
1	CAMU0013	Set of three shoes, springs, bolts, flat washers & nuts
2	CAMU0010	Set Of three springs, washers, bolts & nuts
4	HCBS0004	One metric clutch bolt

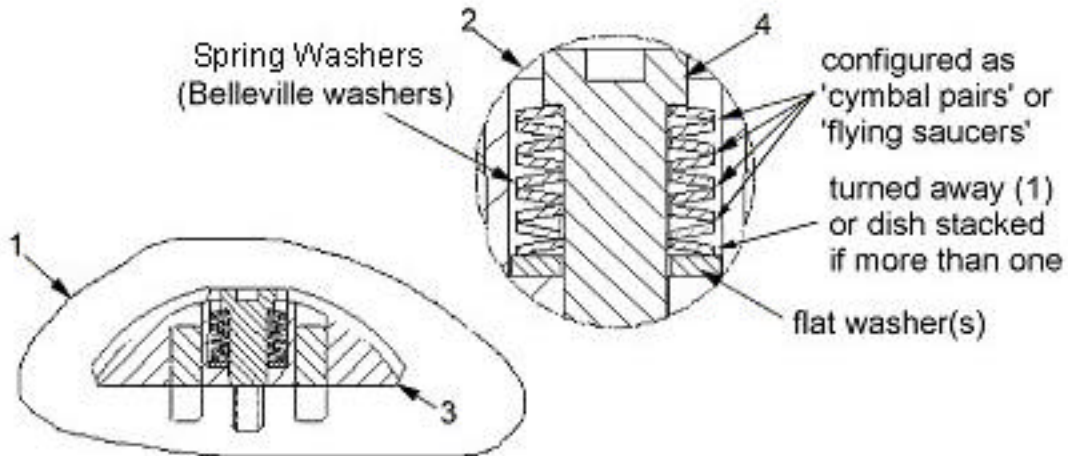

Figure 32 Some configuration of clutch spring stack. Each 'spring' stack contains multiple springs (Belleville washers) - arranged into three, four, or five 'flying saucers', or turned away against the flat washer(s). Shown is the 4 ½ stack..

Stack	Total Springs	Flying Saucers or Cymbal Pairs	Turned Away or Dish Stacked	Std. Flat Washer
5 ½	11	5	1	

Clutch adjustment washers

Your Cobra comes stock with flat washer(s) at the bottom of the spring washer stack. Cobra offers several thicknesses of thin adjustment washers that allow clutch engagement tuning. Increasing the flat washer(s) thickness increases the engine speed for clutch engagement thus increasing the abruptness of clutch engagement (harder hit). Conversely, decreasing the flat washer(s) thickness decreases the engine speed for clutch engagement thus decreasing the abruptness of clutch engagement (softer hit).

Part #	Thickness mm (inch)
HKCSM015	1.5 (0.060)
HKCSM012	1.2 (0.047)
HKCSM008	0.8 (0.031)
HKCSM006	0.6 (0.025)
HKCSM005	0.5 (0.020)
HKCSM004	0.4 (0.015)

Use the table above to order adjustment washers. Replace the stock washer with the proper combination of adjustment washers that delivers the desired clutch hit.

Hit	Thickness (mm)	Thickness (inch)
Softer ↑	0.8	0.031
	0.9 (0.4 + 0.5)	0.015 + 0.020
	1.0 (0.5 + 0.5)	0.020 + 0.020
Harder ↓	1.1 (0.6 + 0.5)	0.020 + 0.025

CAUTION:

It is easy to prematurely damage the clutch and other engine components with improper clutch adjustment. If you are unsure of how to adjust the clutch, by even the slightest, contact the Cobra Technical Support Group before making adjustments.

Clutch shoe wear:

- If the clutch has been slipping and shows signs of glazing, it is best to replace the shoes. We have found that once the shoes are glazed, even if deglazed with emery paper or a file, the performance is reduced.
- The best way to prevent glazing is by not gearing too high, changing the oil as specified and by not blipping the throttle. Every time you blip the throttle, you are working your clutch springs.

CAUTION:

The clutch produces a tremendous amount of heat and when a rider is blipping the throttle. This makes the clutch and clutch springs wear out quicker. This also makes your engine tend to run hotter which decreases engine power and degrades ignition stator efficiency. It is important to train your rider **NOT** to be a **throttle 'blipper'**.

CAUTION:

Sludge build-up between the spring washers also keeps the clutch shoe from engaging fully and this will cause the clutch to start to slip. So you will need to clean the sludge out or just replace the spring washers and bolts with new ones. How quickly this sludge builds up depends on how often you **change your oil** and whether your rider is a throttle 'blipper'.

REF #	PART NO.	DESCRIPTION
1	ECMU0118	Crank seal
2	ECMU0040	Clutch to hub spacer (standard 0.030" 0.76mm)
	ECMU0040T	Clutch to hub spacer (thin, 0.015" 0.38mm)
3	ECMU0119	Needle bearing
4	ECMU0120	Clutch basket with bearing
5	CAMU0005	Clutch Complete w/ Arbor
6	ECMU0018	Clutch nut
	CCMU0029	Clutch arbor

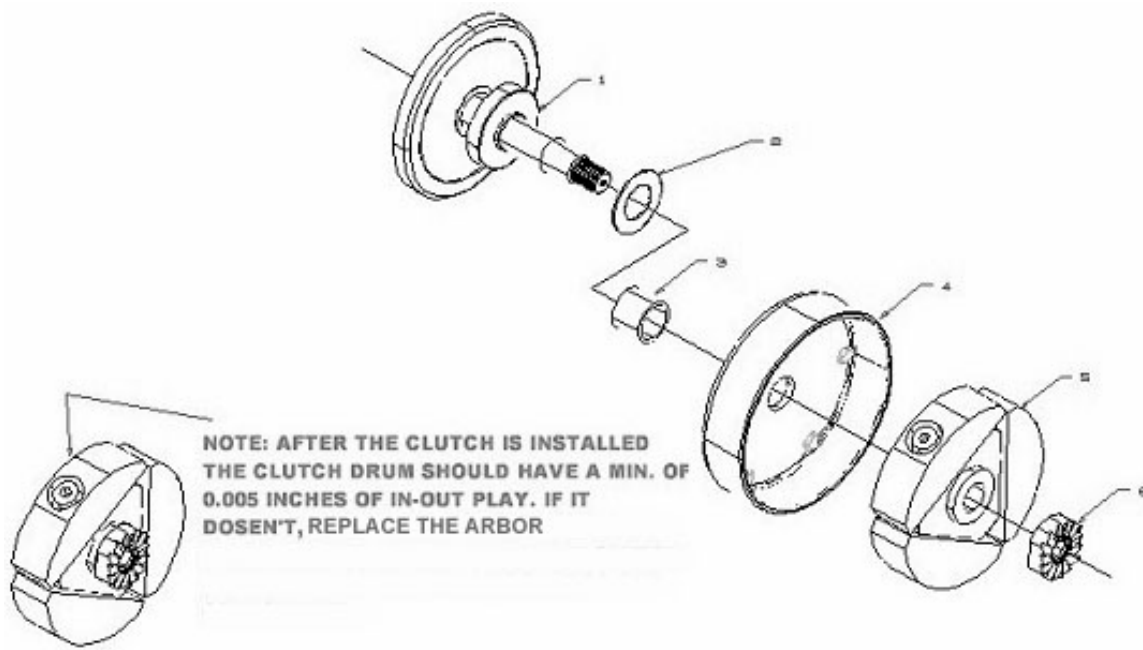

Figure 33, Clutch Assembly Drawing

CLUTCH ASSEMBLY:

1. After cleaning or replacing the spring washers, reassemble the stack up of washers.

CAUTION:

It is important to reassemble the washer stack to that which is recommended or to your own specialized stack.

CAUTION:

It is also important that all three shoes are stacked the same. (See figure 32)

2. Clean the threads of the stack bolt and the clutch with contact cleaner removing all old thread locking material.
3. Apply high strength thread lock material to the stack bolt and tighten to 12 ft-lb (16 N-m).

CAUTION:

Avoid allowing excess thread lock material to contact the spring washers and the clutch or the clutch is likely to malfunction.

4. Clean the center hole of the clutch and on the tapered section of the crankshaft.
5. Apply a small amount of wicking / bearing retainer (green) thread lock agent to the center tapered section of the crankshaft and taper of clutch arbor.

CAUTION:

Lean the bike / engine such that any excess thread lock agent goes away from the bushing in the clutch drum.

6. Put the clutch back in.
7. Apply high strength thread locking agent to the threads and install the nut and torque to 40 ft-lb (54Nm) with the special socket (see figure 33).

CAUTION:

Use high strength (red) thread locker on the threads of the clutch nut. If you are using an impact socket, just zap it lightly with an air wrench to tighten it because there are only about 4 threads inside the nut and they can be easily stripped. If you are tightening it by hand, you can hold the crank from turning with the clutch removal spanner ECMU0082.

Install the clutch cover tightening the bolts from inside out. (8 or 10 mm socket, 5.8 ft-lb, 7.8 Nm).

INSPECTION NOTE:

- a. There must be in / out play in installed clutch, 0.4mm to 1.0 mm (0.015" to 0.040").
- b. Excess in/out will cause early crank seal failure.
- c. A blue clutch drum is worn out from excessive slippage or improper lubrication.

NOTE:

To ensure proper engagement of the kick gear with the starter nut, tighten the six screws only to the point of being not extremely loose. Using one hand rotate the kick lever to ½ stroke and hold while tightening the six screws completely with the other hand.

8. Fill with oil (235 ml (8.0 oz) *Cobra 3 Shoe Clutch Milk* (Part # MCMUGF01)).

Ignition

Stator care

Stator failure will result from running the bike hot. Following is a list of things that will make your engine run hot.

1. The timing should not exceed the maximum specifications listed.
2. Improper carburetor jetting.
3. Improper spark plug heat range. Never run a hotter plug than the specified spark plug.
4. Clutch slippage. See "CLUTCH" section for causes of slippage.

CAUTION:

- Because of the amount of heat generated by the clutch and engine during extended periods of riding, it is advisable to remove the ignition cover afterward to allow the ignition to cool off. The heat transfers through the cases

and can damage the stator as it cools off because of lack of airflow around the stator.

- Ignition will overheat if the gap between the rotor and stator is not large enough. There should be even clearance as the rotor rotates relative to the stator.
- Ignition timing is not adjustable. Changing the ignition timing can degrade performance.
- Make sure connections are free of dirt.

CAUTION:

Advancing the ignition timing will cause the engine to run hotter, in-turn causing power loss, shortened clutch life, and possibly lead to premature stator failure, and can also cause detonation which can lead to premature piston and ring failure.

Tools recommended for timing service:

- Compact motorcycle dial indicator
- Universal clutch puller- a universal puller that pulls the clutch, main drive gear and rotor. (Part # MCMUTL70).

CONFIRM YOUR IGNITION TIMING:

1. Remove the spark plug.
2. Insert the dial indicator into the spark plug hole.
3. Remove the four bolts from the ignition cover.
4. Remove the water pump belt from the rotor and water pump shaft.
5. Turn the crankshaft counterclockwise until it reaches top dead center.
6. Set the dial indicator to zero
7. Turn the crankshaft clockwise until the dial indicator reaches 0.040" (1.0 mm) from top dead center.
8. At this position the line on the rotator should align with the center of the stator coil at 2 o'clock position on stator frame. If not call Cobra support line.

ROTOR INSTALLATION:

1. Torque the nut on the rotor to 35 ft-lb (47 Nm) with high strength (red) thread locking agent.
2. Recheck the timing following the procedure of *timing your ignition*.
3. Install the water pump belt back on.
4. Bolt the ignition cover back on.
5. Put the spark plug back in, and firmly stick the spark plug cap onto the spark plug.

Cooling System

Radiator fluid removal:

Remove the coolant drain plug (13mm bolt) on the front of the engine cases.

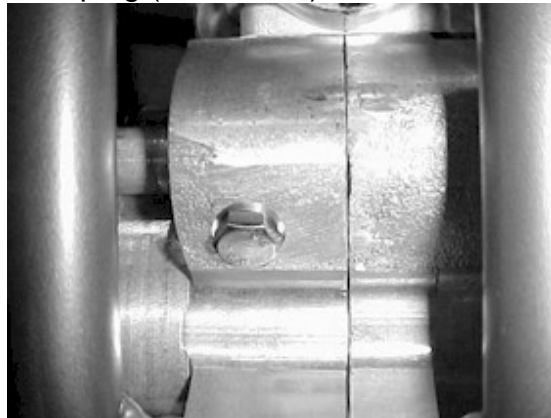

NOTE: Inspect the old coolant for evidence of oil, combustion byproducts (black 'oil slick' stuff) or other things that may indicate a problem.

Tools recommended for impeller service:

- Flat head screwdriver
- 13mm- hex wrench
- 3mm hex key
- 4mm hex key
- 5mm hex key
- 8mm hex key
- Water Pump Installation tool
 - MCMUTL09, 2009 King
 - MCMUTL08, 2009 JR & all older models
- Slide hammer with
 - fitting to thread into threads on end of shaft (M5x1.0)
 - single and double hook ends for removing plastic impeller
- Dead blow hammer

COBRA IMPELLER SERVICE INSTRUCTIONS

1. Remove radiator cap and drain engine coolant as described above.

NOTE:

If the impeller is damaged or broken completely back flush the coolant system to ensure no solid pieces are in the system.

2. Remove ignition cover using a 4mm hex key (four places)
3. Stick a 3mm hex key in the water pump shaft cross hole, and remove belt retainer screw using a 4mm hex key. (Figure 41 - item 1)
4. Remove belt retainer, water pump belt and water pump fan pulley.
5. Remove bearing retainer screw using a 3mm hex key.

6. Thread a slide hammer onto the end of the water pump shaft and remove the assembly.



NOTE:

It is quite common for the older plastic impellers to fall off the end of the shaft during this step of the process if that is the case, then follow the steps at the end of this section to remove the seal and impeller.

7. Clean any debris or particles from the bore and use some light emery cloth to remove any scratches in the surface that the removal process may have created.
8. Lubricate the bore with grease.
9. Prepare for assembly by installing the water pump assembly into the assembly tool and align the tool with engine case making sure alignment pin is in proper hole.

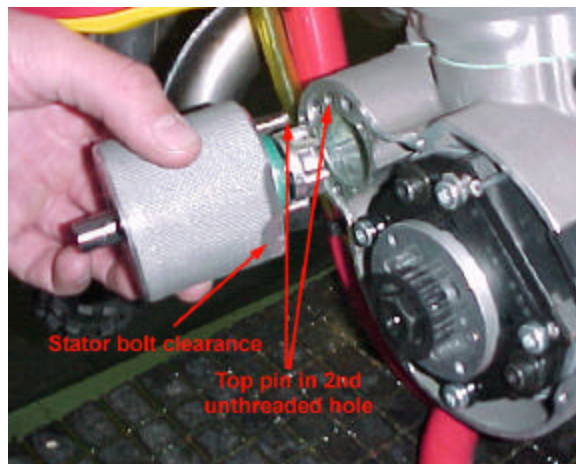

CAUTION:

Damage may occur if one attempts to install the water pump and the device is not orientated correctly. If the tool does not sit flat against the cases, the orientation of the tool to the engine is not correct. Make sure that the top alignment pin is in the 2nd unthreaded hole, the bottom alignment pin is also in the 2nd unthreaded hole, and that the relief for the stator bolt head is oriented toward the stator.

10. Hold the installation tool firmly against the engine case and tap on the end of the water pump shaft with a dead blow hammer until the insertion punch is needed



11. Continue driving the assembly with the punch until the head is flush.

NOTE:

The insertion punch is 0.010" (0.25mm) longer than the housing so as to seat the water pump assembly just in from the case surface.

12. The assembly is installed properly when the retaining screw can be tightened and it does not cause a bind on the spinning shaft (use medium strength thread lock on the retainer screw).

NOTE:

It may be necessary to tap the water pump shaft in (hammer) and out (with slide hammer) to insure proper free operation of the shaft.

13. Reinstall the pulley, belt and fan cover using a 3mm hex key to stop the rotation of the water pump assembly while tightening with medium strength thread lock to 10 ft-lb (14Nm).

14. Reinstall the cover

NOTE:

Refill the coolant system with 50/50 antifreeze-coolant / distilled water.

CAUTION:

Do not mix Propylene Glycol based coolant / antifreeze solutions with Ethylene Glycol based coolant / antifreeze solutions.

Fuel & Air System

Carburetor:

Tools recommended for carburetor service:

- Small flat head screwdriver
- WD-40
- 8mm socket

Your Cobra is equipped with an adjustable carburetor. Some fine-tuning may be needed according to weather condition and altitude. Proper jetting is **very** important for engine performance and engine life. Serious damage to the engine can occur if not properly adjusted.

IDLE ADJUSTMENT:

On the left side of the carburetor, there are two adjustment screws. The larger screw with the knurled head is the idle adjustment screw. To raise the idle, turn the screw in clockwise (in 1/4 turn increments) and rev the engine after each adjustment. To lower the idle, turn the screw counter-clockwise.

TOP END JETTING:

Indications that the engine is running too rich (too much fuel for the air) are:

- Engine not revving out or blubbering at high RPMs.
- Engine will not 'clean out'
- Wet or black spark plug

NOTE: Before changing jetting be sure that the air filter is properly cleaned and has the usual amount of air filter oil. An overly dirty air filter can cause the engine to run rich.

If the engine is running rich on the top end it should be leaned out. Leaning it out can be done by:

1. Changing the main jet to a smaller number.
2. Raising the needle clip (this lowers the jet needle) one notch at a time on the slide.

Indications that the engine is running too lean are:

- Engine cutting out on top end.
- Engine overheating and ultimately seizure.
- White spark plug

CAUTION:

It is much safer to operate the engine slightly rich as opposed to slightly lean. This is because an overly rich engine will just run poorly while an overly lean engine will seize, potentially causing an expensive top end rebuild and a DNF.

To richen the carburetor:

1. Change the main jet one number at a time (larger).

2. Lower the needle clip (raising the jet needle) one notch at a time until the engine starts to blubber on the top end, then move the clip back up one notch or until you get the blubber out.

FUEL MIXTURE SCREW

The smaller brass screw that is towards the front of the engine is a fuel mixture screw. This screw will also richen and lean your engine more on the bottom and mid-range. In warmer conditions, turn the screw in. In colder conditions, turn the screw out. Be sure to keep the carburetor very clean and make sure you don't have water or dirt in the carburetor bowl. Use automotive carburetor cleaner or WD-40 to clean the carburetor inside and out.

STOCK CARBURETOR SETTINGS

The 2008 CX50 SR stock carburetor settings from the factory are:

- 60 pilot jet
- 95 main jet

Cleaning the carburetor:

⚠ WARNING

Clean the carburetor in a well-ventilated area, and take care that there is no spark or flame anywhere near the working area; this includes any appliance with a pilot light. Because of the danger of highly flammable liquids, do not use gasoline or low flash-point solvent to clean the carburetor.

1. Make sure the fuel is shut off.
2. Remove the carburetor.
3. Drain the fuel from the carburetor.
4. Disassemble the carburetor.
5. Immerse all the metal parts in a carburetor cleaning solution.
6. After the parts are cleaned, dry them with compressed air.
7. Blow out the fuel passages with compressed air.
8. Assemble the carburetor
9. Install the carburetor onto the motorcycle.

CAUTION:

1. The motorcycle will only operate properly if the carburetor top is installed properly with the mounting screws, cable and choke knob oriented as shown.

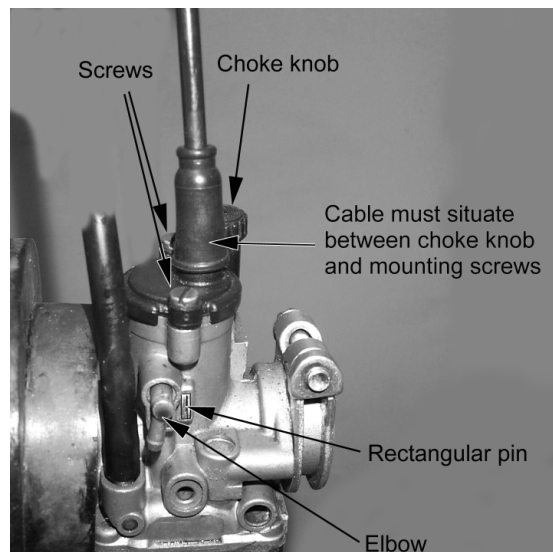

Reeds:

- If the reed is damaged in any way, replace it. This means cracks, chips, and ruptures. Anything abnormal, replace the reeds.

NOTE:

If you are having difficulties getting the jetting established at higher elevations, try using the stiff reed pedals, ECCS0003.

Take the reed cage out and hold it up to the light and look in through the cage. If you see light, it is not necessarily a bad thing, but the pedals may need to be replaced. (See figure 44) Bikes have been known to run real well with light visible past the reed tips as long as the jetting proper for the conditions.

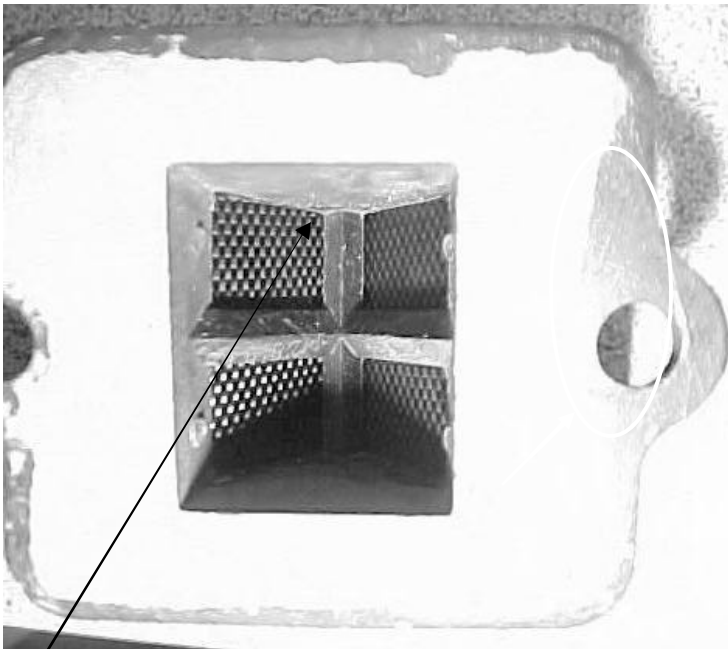

Figure 44

The presence of light may indicate that the reeds may need to be replaced, or possibly turned over.

Exhaust

The pipe is a crucial element to a motorcycle. Any kinks, dents, or damage done to the pipe will result in a major performance loss.

NOTE:

Be sure to take the pipe off, and any carbon that may be built up. Carbon build up is created from exhaust. Exhaust has oils in it, and the oils cling to the walls of the inside of the pipe. Over a long period of time, the diameter of the pipe will decrease, due to carbon build up. So it is essential to clear the residue.

NOTE:

If your bike sounds louder than normal, this is a strong indication that your silencer needs repacked. Wheels & Tires

Rear wheel pullers

Disassembly:

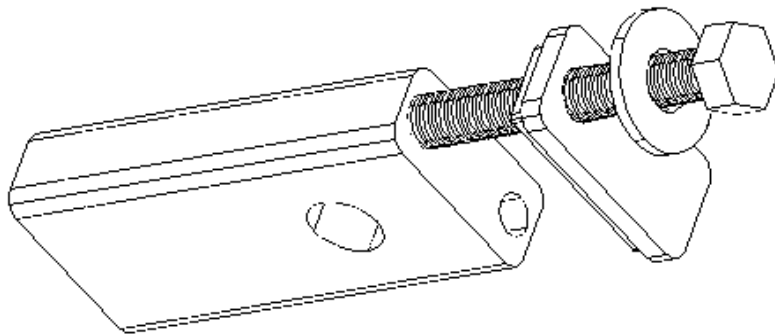

1. Remove axle, and back wheel assembly.
2. Pull the rear wheel pullers out of the back of the swing arm.

Figure 45

Rear wheel alignment:

By eye, ensure that the rear sprocket is running true (in-line, planar) with the front sprocket. When the sprockets are running true, the wheel is properly straightened, and the chain will run straight.

Brakes

Check before each ride:

- Make sure the brake does not have any leaks by holding the lever in while checking hose connections.
- Make sure the brake lever pressure is OK by pulling in on the lever and ensuring full braking performance is achieved before the lever touches the handlebar. If this is not the case, pump the lever several times until the lever feels firm.
- Always make sure the rotor and brake pads are free from oil and grease. Clean the rotor with mild dish soap or alcohol. Contaminated pads must be replaced.
- Ensure that the brake caliper is centered over the brake rotor. If a correction is needed, Cobra has thin brake shims to help make minor adjustments in alignment.
- Always leave adequate free-play in the lever or pedal.

CAUTION:

This brake system uses only DOT 4 or 5.1 brake fluid!

Front Forks

Tools recommended for front fork service:

- Flat head screwdriver
- Hammer
- Pick
- Seal driver MCMUTL02
- 9/16" (loose 14 mm) wrench
- 25mm wrench or socket
- 5 wt fork oil

FORK DISASSEMBLY PROCEDURES:

1. Using the 25mm wrench, remove the fork cap.
2. Drain the fork oil into a suitable container.
3. Disconnect the fork cap from the damper rod (9/16" wrench & 25mm wrench).
4. Disconnect the damper assembly from the fork leg by removing the large aluminum bolt from the bottom of the fork leg (22mm wrench).
5. Pry the dust seal (swiper) from its position with a small screw driver.
6. Using a pick, remove the wire retaining ring holding the fork seals into place.
7. 'Pop' the fork seal out by forcibly pulling on both ends of the fork tube assembly, thus separating the inner from the outer tube.
8. Remove the bushings
9. Clean all components to be reused.

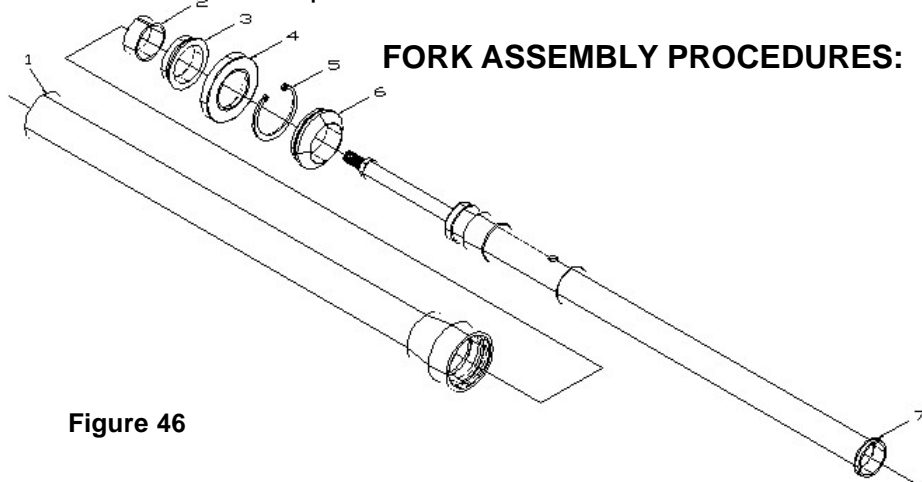

Figure 46

CAUTION:

Make sure all components are clean before assembly.

CAUTION:

Be sure to apply oil to the new fork seal and other components before installing.

1. Slide dust seal (swiper) (#6) onto lower fork leg.
2. Slide retaining ring (#5) onto lower fork leg.
3. CAREFULLY slide seal (#4) onto lower fork leg with spring facing away from snap ring.

CAUTION:

It is helpful to cover the sharp corners of the fork leg with tape or thin plastic before sliding on the new seal. Also take care that the inner lip is not folded over when installing.

4. Slide bushing (#3) onto lower fork leg.
5. Install the glide ring into groove on lower fork leg.
6. Slide the bushing over the glide ring about 1/4" to hold the glide ring in the groove.
7. Insert the lower leg assembly into the upper fork tube about 5-6".
8. Use a seal driver to drive the seal into the upper tube.
9. Install the retaining ring. Make sure it is properly seated in the groove.
10. Snap the dust seal (swiper) into the groove in the upper tube.
11. Reinstall the damper cartridge assembly to the fork leg. Secure the large bolt with 22 mm wrench to 35 ft-lb with green thread locking agent.
12. Fill with 3.6 oz (107 ml) 5 wt fork oil should measure 6 mm (0.25") above the damper cartridge tube with spring removed. (This oil volume works out to leave an oil height of 120mm from top of outer tube with forks collapsed, damper rod down, and spring removed).
13. Install the fork spring
14. Connect the cartridge rod to the cap and tighten to 12 ft-lb (16 Nm).

CAUTION:

The damper rod is hollow and will break if the nut is over tightened (proper torque is 12 ft-lb, 16 Nm).

Because of different rider weights, sizes and riding styles, we offer various suspension options:

See *Optional Components* section of this manual for details on these and other optional components for your Cobra Motorcycle.

Rear Shock

The rear shock is fully serviceable but it is recommended that only trained professionals should service your shock. Contact Cobra or PR2 for questions and service of your CX50 sr shock.

Shock preload

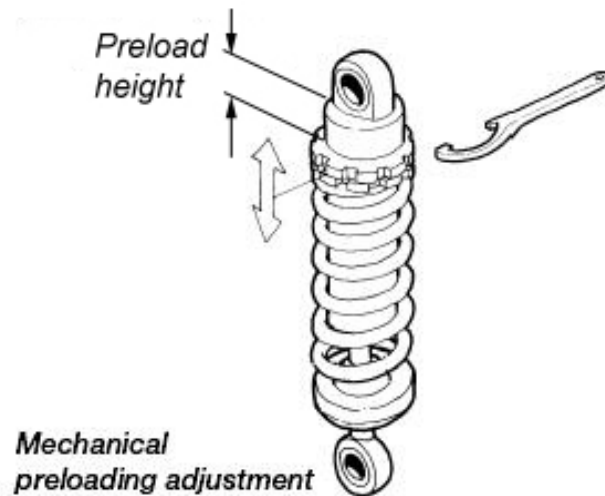

Figure 47

Shock Damping

11. Adjustment of rebound damping

12. Adjustment of compression damping



Figure 48

Tuning

Gearing

For a bike with a centrifugal clutch, it's better to be geared too low than too high.

What happens with improper gearing?

- Poor performance
- Not enough top end speed
- No snap
- Over heat clutch
- Premature failure of engine seals, bearings, & electronics
- High clutch wear

Condition	Gear Taller	Gear Lower
Mud		↓ ↓
Sand		↓
Hills		↓
Hard Pack	↑	
Throttle Blipper (novice)		↓ *

*It may be helpful to set up the clutch to hit early for smooth power delivery

Front Sprocket			Rear Sprocket	Gear Ratio
		15	33	2.20
		15	34	2.27
		15	35	2.33
	14		33	2.36
		15	36	2.40
	14		34	2.43
		15	37	2.47
	14		35	2.50
		15	38	2.53
13			33	2.54
	14		36	2.57
		15	39	2.60
13			34	2.62
	14		37	2.64
		15	40	2.67
13			35	2.69
	14	stock	38	2.71
		15	41	2.73
13			36	2.77
	14		39	2.79
		15	42	2.80
13			37	2.85
	14		40	2.86
13			38	2.92
	14		41	2.93
13			39	3.00
	14		42	3.00
13			40	3.08
13			41	3.15
13			42	3.23

Ratio Write © Cobra R&D 2004

Suspension

Adjustment:

1. Front forks
 - 1.1. Fork oil
 - 1.1.1. Oil type
 - 1.1.1.1. Heavier weight oil – more damping – slower responding
 - 1.1.1.2. Lighter weight oil – less damping – quicker responding
 - 1.1.2. Oil quantity / level
 - 1.1.2.1. Greater quantity / higher level – greater bottoming resistance, stiffer near the end of the travel.
 - 1.1.2.2. Smaller quantity / lower level – less bottoming resistance, less stiff near the end of the travel.
 - 1.2. Fork spring
 - 1.2.1. Stiffer spring (higher spring rate) – stiffer throughout the travel.
 - 1.2.2. Less stiff spring (lower spring rate) – less stiff throughout the travel.
 - 1.3. Gas pressure – always bleed off any pressure.
 - 1.4. Fork height
 - 1.4.1. Rise in clamps for quicker turning.
 - 1.4.2. Lower in clamps for improved straight line stability.
2. Rear shock
 - 2.1. Preload adjustment
 - 2.1.1. More preload (greater distance) – less race sag.
 - 2.1.2. Less preload (smaller distance) – more race sag.
 - 2.2. Shock spring
 - 2.2.1. Stiffer spring – stiffer throughout the travel.
 - 2.2.2. Less stiff spring – less stiff throughout the travel.
 - 2.3. Compression damping
 - 2.3.1. Harder (more damping, slower) – adds resistance to the suspension motion when the suspension is compressing.
 - 2.3.2. Softer (less damping, quicker) – reduces resistance to the suspension motion when the suspension is compressing.
 - 2.4. Rebound damping
 - 2.4.1. Harder (more damping, slower) – adds resistance to the suspension motion when the suspension is returning to full length.
 - 2.4.2. Softer (less damping, quicker) - reduces resistance to the suspension motion when the suspension is returning to full length

Front Forks Bottoming Too Frequently

Fork oil level

If the front forks bottom harshly more than a couple of times per lap and the fork springs are proper for the weight of rider (as detailed above), try raising the fork oil level in increments of 10mm. Raising the fork oil level, reduces the air volume, and increases the stiffness of the forks late in the travel, thus adding a progressive' feel.

Front forks feel too stiff over small bumps.

Fork oil weight

If the forks feel too stiff over small bumps try decreasing the weight (increasing the viscosity) of the fork oil.

Rear suspension troubleshooting.

Damping

Always start with standard settings and make damping changes in no more than two click increments and only make one change at a time.

Symptom	Action
Rear end feels stiff on small bumps	Softer compression damping
Rear end 'sways' on straights	Harder compression damping
Bike tends to jump 'rear end high'	Harder rebound damping
Bike tends to jump 'rear end low'	Softer rebound damping
Frequent rear end bottoming	Harder compression damping
Bottoms after end of continuous bumps	Softer rebound damping
Rear end 'kicks' over square edge bumps	1) Harder rebound, 2) Softer Compression

Proactive Suspension Adjustments

Once you have the suspension adjusted for decent overall feel, you can make proactive adjustments when faced with different racing conditions.

Situation	Actions
Sand track	Lower the rear end (increase race sag).
Sand track	Stiffer compression and rebound damping.
Long fast track	Lower the forks in the clamps by 3 mm.
Tight slow track	Raise the forks in the clamps by 3 mm.
Mud track	Lower the bike if the rider has difficulties touching the ground.

Carburetion

Although your Cobra is sent from the factory with the carburetor jetted for optimal performance, you may find it necessary to adjustment your particular jetting due to current weather conditions, altitude, fuel variations, and/or engine modifications.

CAUTION:

Proper jetting is very important for engine performance and engine life. Symptoms of improper jetting are listed below.

- Symptoms of incorrect oil or oil / fuel ratio
 - Poor acceleration

- Misfire at low engine speeds
- Excessive smoke
- Spark plug fouling
- Excessive black oil dripping from exhaust system
- Symptoms of too rich a fuel mixture
 - Poor acceleration
 - Engine will not 'rev' out, blubbers on top
 - Misfire at low engine speeds
 - Excessive smoke
 - Spark plug fouling
 - Wet, black, or overly dark spark plug (when removed for inspection)
- Symptoms of too lean a fuel mixture
 - Pinging or rattling
 - Erratic acceleration
 - Same actions as running out of fuel
 - High engine temperature
 - White spark plug (when removed for inspection)

NOTE:

When inspecting the spark plug to evaluate jetting, a properly jetted machine will produce a spark plug that is dry and light tan in color.

Environmental and altitude related mixture adjustments		
Condition	Mixture will be	Required adjustment
Cold air	Leaner	Richer
Warm air	Richer	Leaner
Dry air	Leaner	Richer
Very humid air	Richer	Leaner
Low altitude	Standard	None
High altitude	Richer	Leaner
Low barometric pressure	Richer	Leaner
High barometric pressure	Leaner	Richer

NOTE:

- Before making any carburetor jetting changes verify that:
 - You are using the proper fuel and oil
 - The fuel is fresh and uncontaminated
 - The oil and fuel have been mixed in the proper ratio
 - The carburetor is clean (no plugged jets)
 - The air filter is properly clean and oiled
 - The float height is within proper specification (proper measuring technique is described later in this section)

NOTE:

Perform all jetting changes on a motorcycle that has been warmed up to proper operating temperature.

The carburetor on your Cobra motorcycle is quite adjustable. Figure 49 shows its range of adjustment and in particular what adjustable component affects what

range of operation (specifically throttle position).

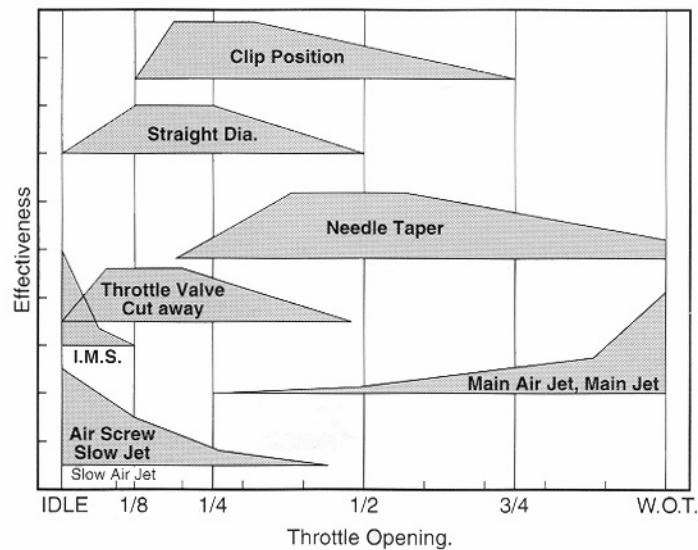

Figure 49

FUEL SCREW ADJUSTMENT: Adjust for maximum idle speed

The fuel adjustment screw is located on the left side of the carburetor. It is the smaller of the two adjustment screws and requires the use of a small flat blade screw driver for adjustment. After adjusting for maximum idle speed, use the idle screw to adjust the desired idle speed.

NOTE:

If the fuel screw requires more than 3 turns out, replace the pilot jet for one that is one size richer (larger number) then readjust the fuel screw.

IDLE ADJUSTMENT: Adjust for desired idle speed

The idle speed screw is located on the left side of the carburetor. It is the larger of the two screws on the side of the carburetor and is unique with its knurled head for easy fingertip adjustment. To raise the idle, turn the screw in, clockwise, (in 1/4 turn increments) and rev the engine after each adjustment. To lower the idle, turn the screw counter-clockwise.

TOP END JETTING: Adjust for clean full throttle acceleration

Jet your top end (main jet) based on the acceleration of your Cobra Motorcycle on the longest straight at the track. Observe any of the lean or rich symptoms (spark plug appearance and bike performance) listed above and change your jetting accordingly.

PART THROTTLE Adjust for desired acceleration

Using an area of the track that allows the rider to operate and mid throttle and transition (accelerate, or 'roll on') from closed, or mostly closed throttle, to a larger throttle opening. Observe the rich and lean symptoms listed above. Adjust the jet needle position by moving the clip from its current position (move the clip higher on the needle to make the bike run leaner, or move the clip lower on the needle to make the bike run richer) to one higher or lower.

Troubleshooting

1) Engine operates erratically

- a) Carburetor top is installed backwards
- b) The carburetor slide indexing pin is missing
- c) A carburetor vent elbow is plugged or has fallen out
- d) Faulty stator
- e) An air leak
 - i) Base gasket
 - ii) Intake / reed gaskets
 - iii) Crank seals
 - iv) Crank case gasket

2) Engine is down on power

- a) Clutch engagement is not set properly
- b) Jetting is incorrect
- c) Silencer needs repacked
- d) Exhaust pipe
 - i) Has excess carbon buildup
 - ii) Has large dent in it
- e) Compression is low
 - i) Piston
 - ii) Rings
- f) Reeds are damaged
- g) Ignition timing is incorrect
- h) Stator needs replaced

3) Engine is excessively loud

- a) Silencer needs repacking

4) Engine 'blubbers' at high RPMs

- a) Jetting too rich
- b) Stator needs replaced

5) Engine won't start

- a) Fuel
 - i) None in tank

- ii) Is sour or bad
 - b) Carburetor is dirty
 - c) Ignition
 - i) Spark plug fouled
 - ii) Spark plug cap off
 - iii) Engine Shut-off 'kill' switch is shorted
 - iv) Bad electrical ground
 - v) Stator winding damaged
 - d) Exhaust is plugged with object of flooded fuel
 - e) Engine is flooded
 - f) Cracked, broken, or jammed reed pedal
 - g) Excessive piston or cylinder wear
 - h) Clutch bolt or shoe dragging on basket (drum).
- 6) Engine won't idle**
- a) Idle knob needs adjusted
 - b) Carburetor jets are dirty

Index

Air Filter.....16 Bars and Controls22 Base Gasket Selection43 Break-In..... 8 Carburetor Parts23 Service59 Specifications 5 CFD Cobra Frictional Drive20 Chain Adjustment..... 14 Chassis Specification..... 5 Clutch Parts27 Service49 Clutch Lubricant Replacing 12 Compression test43	Cooling System.....56 Cylinder head torque 6 Electrical Parts25 Engine Specifications 5 Exhaust61 Parts30 Fork oil replacement 19 Forks Parts31 Service63 Frame Parts.....33 Frictional Drive20 Front Brake Parts35 Front Wheel Parts36 Fuel System Parts list59
--	---

Service	59	Swingarm	41
Hardware		Top End	29
Frame	33	Triple Clamps	31
Plastic.....	37	Plastic & Seat Parts	37
Ignition		Pullers	62
Parts	28	Rear Brake	
Service	54	Adjustment.....	14
Timing.....	55	Parts	38
Jetting		Rear Wheel	
How To	59	Parts	39
Stock.....	5	Pullers	62
Troubleshooting	69	Reeds	61
Lubrication		Shock	
Recommended	5	Parts	40
Maintenance		Service	71
Schedule	10	Slip Clutch	20
Tips.....	10	Spark Plug	
Oil		Recommended	5
Recommended	5	Specifications	5
Optional components	6	Starting	9
Parts		Stator	
Bars and Controls	22	torque	7
Bottom End & Transmission	26	Suspension.....	71
Carburetor	23	Swingarm	
Clutch & Kick Starter.....	27	Parts	41
Coolant System	21, 24	Top End	
Electrical	25	Parts	29
Engine	26	Service	42
Exhaust	30	Torque Values.....	6
Forks.....	31	Transmission Lubricant	
Frame	33	Replacing	12
Front Brake.....	35	Troubleshooting	72
Front Wheel.....	36	Jetting	69
Ignition & Water Pump.....	28	VIN reading	11
Plastic & Seat.....	37	WARNING	2
Rear Brake	38	Water Pump	
Rear Wheel	39	Parts	28
Shock.....	40	Wheels	
		Service	62