



**ECX80 AC**

**2009**

**Owners Parts Service Tuning**

**CHAMPIONS START HERE**

For **parts orders** contact your local dealer

To locate your closest Cobra dealer  
log on to

[www.cobramotorcycle.com](http://www.cobramotorcycle.com)

or call

(517) 437-9100

If you need **technical assistance**  
contact your local dealer or call  
the Cobra Technical Support Hotline at  
(517) 437-9100



Cobra Motorcycle MFG., Inc.  
240 Uran Road  
Hillsdale, MI 49242

## DISCLAIMER OF WARRANTY

*This motorcycle is sold "as is" with all faults, obvious or not. There are no warranties expressed or implied, including any warranty of merchantability and warranty of fitness for any particular purpose.*

## **"WARNING"**

THE COBRA ECX80AC IS A COMPETITION MODEL ONLY AND IS **NOT** MANUFACTURED FOR, NOR SHOULD IT BE USED ON PUBLIC STREETS, ROADS OR HIGHWAYS.

THE USE OF THIS ATV SHOULD BE LIMITED TO PARTICIPATION IN SANCTIONED COMPETITION EVENTS UPON A CLOSED COURSE BY A SUFFICIENTLY SKILLED RIDER AND SHOULD NOT BE USED FOR GENERAL OFF-ROAD RECREATIONAL RIDING.

IMPROPER USE OF THIS MOTORCYCLE CAN CAUSE INJURY OR DEATH.

THIS BIKE IS INTENDED FOR EXPERIENCED RACERS ONLY AND NOT FOR BEGINNERS.

IT IS **YOUR RESPONSIBILITY** AS THE OWNER OF THIS COBRA PRODUCT OR AS THE PARENT, OR LEGAL GUARDIAN OF THE OPERATOR, TO KEEP THIS COBRA PRODUCT IN PROPER OPERATING CONDITION.

THIS ATV WAS DESIGNED FOR RIDERS THAT WEIGH LESS THAN 110 LBS WITH FULL RIDING GEAR AND SHOULD NOT BE OPERATED BY RIDERS THAT WEIGH MORE THAT.

BE SURE THAT THE RIDER ALWAYS WEARS ADEQUATE SAFETY GEAR EVERYTIME HE OR SHE RIDES THEIR COBRA ATV.

## IMPORTANT SAFETY NOTICE

### **WARNING**

Failure to follow WARNING instructions could result in severe injury or death to the machine operator, a bystander, or a person inspecting or repairing the machine.

### **CAUTION:**

A CAUTION indicates special precautions that must be taken to avoid damage to the machine.

### **NOTE:**

A NOTE provides key information to make procedures easier or clearer.

# Table Of Contents

General Information .....	3
Specifications - General .....	3
Specifications - Torque Values.....	4
Optional Suspension Components .....	5
Starting Procedure .....	8
General Tips.....	9
Maintenance .....	10
Schedule & Tips .....	10
M1: Replacing Transmission Lubricant .....	11
M2: Chain adjustment .....	12
M3: Air Filter Cleaning.....	13
M4: Front end.....	14
Toe in adjustment .....	14
Steering .....	14
Parts .....	15
Parts – Air Inlet System.....	15
Parts – Bars and Steering .....	16
Parts – Bumper, Nerf & Grab Bars .....	17
Parts – Carburetor.....	18
Parts – Clutch Actuation.....	19
Parts – Coolant System.....	20
Parts – Electrical System .....	21
Parts – Engine Clutch.....	22
Parts – Engine – Clutch / Kick Cover .....	23

Parts - Engine - Ignition Side .....	24
Parts - Engine – Kick Mechanism .....	25
Parts – Engine – Shift Mechanism.....	26
Parts – Engine – Top End.....	27
Parts - Engine - Transmission.....	28
Parts – Exhaust System .....	29
Parts - Front A-Arms & Steering Upright .....	30
Parts – Front Brakes .....	31
Parts – Front Shock.....	32
Parts – Miscellaneous .....	33
Parts – Plastic Bodywork & Seat.....	34
Parts – Rear Brake.....	35
Parts – Rear Drive.....	36
Parts – Rear Shock .....	37
Parts – Swingarm Assembly.....	38
Parts – Tie Rod Assembly .....	39
Engine Parts / Service .....	40
Engine Service .....	40
Base Gasket Selection .....	41
Fuel & Air System.....	43
Reeds .....	43
Carburetor Cleaning .....	44
Exhaust .....	44
Tuning.....	45
Carburetor .....	45
Jetting Decisions.....	45
Troubleshooting .....	48

# General Information

## Specifications - General

Items	ECX80 AC
<b>Dimensions</b>	
Wheelbase	42" (1067mm)
Width Front / Rear	43" / 46" (1092mm / 1168mm)
Weight	210 lb
<b>Engine</b>	
Type	2-stroke, single cylinder, reed valve
Cooling system	Liquid-cooled
Displacement	64.8 cc (3.95 Cubic inches)
Bore and stroke	47.6 mm x 44.7 mm
Ignition system	Digital Electronic
Spark plug	Champion 8339
Gap	0.023" – 0.025" (0.58 – 0.64 mm)
Fuel type	93 octane pump gasoline <b>OTHER RACE FUELS ARE NOT RECOMMENDED</b>
Oil type	<i>Cobra Venom 2-cycle Race Oil</i>
Fuel / oil mix ratios	32:1
Ignition timing	.050" (1.3mm) BTDC
Carburetion	26mm Mikuni VM
Main jet	190
Slow (Pilot) jet	50
Jet needle	5F21, 4th position from the top
Float height	
<b>Transmission</b>	
Speed	Six speed
Clutch	Manual hydraulic
Final drive ratio	14/48 T
Transmission / clutch oil type	<i>Cobra Power Shift Transmission Lubricant</i>
Quantity	530 ml (18 oz)

<b>Chassis</b>	
Tire Pressure front / rear	(7 psi / 5 psi)
Travel, front / rear	240mm / 247mm (9.4" / 9.7")
Race sag, front / rear	96mm / 99mm (3.8" / 3.9")
Free sag, front / rear	38mm / 40mm (1.5" / 1.6")

## Specifications - Torque Values

ENGINE Fastener	Torque Value			Size & Remarks
	ft-lb	in-lb	Nm	
Cylinder head nuts	14	170	19	7mm
Engine oil drain	3	36	4	8 x 1.25
Engine oil fill	2	24	2.7	14 x 1.0
Spark Plug	(SP)	(SP)	(SP)	14 x 1.25
Crank case half	5	60	6.8	6 x 1.0
Crank case cover	5	60	6.8	6 x 1.0
Flywheel rotor nut	40	480	54	10 x 1.25 (G)
Clutch hub	40	480	54	10 x 1.25 (G)

**Units of mm unless otherwise specified**

**(G)** denotes the use of wicking / bearing retainer (green) thread locking agent to applied to the mating surfaces of the two components but not the threads.

**(SP)** To apply the proper torque to the spark plug when inserting, one must first screw the spark plug in until the metal gasket ring causes resistance and then turn another 1/8 to 1/4 turn.

CHASSIS Fastener	Torque Value			Size & Remarks
	ft-lb	in-lb	Nm	
Handle bar mounts	15	177	20	8 x 1.25
Handle bar clamps	15	177	20	8 x 1.25
Front engine mount	22	265	30	8 x 1.25
Rear brake lever pivot	10	120	13.6	8 x 1.25
Upper shock mount	40	480	54	10 x 1.5
Lower shock mount	40	480	54	10 x 1.5
Swingarm pivot	75	900	102	14 x 2.0

Units of mm unless otherwise specified

**(R or G)** designates that the application requires the use of high strength (red or green) thread locking agent applied to the threads.

**(B)** designates that the application requires the use of medium strength (blue) thread locking agent applied to the threads.

## Optional Suspension Components

Front shock springs

Weight of Rider (lb)	Helper	Main
Less than 65	SCEX0065P (SILVER, 65 LB/IN)	SCEXA135 (BLUE, 135 LB/IN)
65 to 100	SCEX1080 (RED, 80 LB/IN)	SCEXA145 (RED, 145 LB/IN)
Greater than 100	SCEX1095 (YELLOW, 95 LB/IN)	SCEXA155 (YELLOW, 165 LB/IN)

Rear shock springs

Weight of Rider (lb)	Main
Less than 65	SCEX2350 (Yellow, 350 LB/IN)
65 to 100	SCEX2375 (Red, 375 LB/IN)
Greater than 100	SCEX2400 (Black, 400 LB/IN)



	Spring Rate (lb/in)	Color	Part Number
Helper	<b>65</b>	<b>Silver</b>	<b>SCEX0065P</b>
	<b>80</b>	<b>Red</b>	<b>SCEX1080</b>
	<b>95</b>	<b>Yellow</b>	<b>SCEX1095</b>
	<b>110</b>	<b>White</b>	<b>SCEDX1110</b>
	<b>125</b>	<b>Gold</b>	<b>SCEX1125</b>
	<b>150</b>	<b>Green</b>	<b>SCEX1150</b>
	<b>175</b>	<b>Black</b>	<b>SCEX0175P</b>
	<b>200</b>	<b>Silver</b>	<b>SCEX0200P</b>
	<b>250</b>	<b>Red</b>	<b>SCEX0250P</b>
	<b>300</b>	<b>Yellow</b>	<b>SCEX0300P</b>
	<b>350</b>	<b>White</b>	<b>SCEX0350P</b>
Fox 8" long main spring (front)			
	<b>105</b>	<b>Orange</b>	<b>SCEX1105</b>
	<b>115</b>	<b>Green</b>	<b>SCEX1115</b>
	<b>125</b>	<b>White</b>	<b>SCEX2125</b>
	<b>135</b>	<b>Blue</b>	<b>SCEX1135</b>
	<b>145</b>	<b>Red</b>	<b>SCEX1145</b>
	<b>155</b>	<b>Yellow</b>	<b>SCEX1155</b>
	<b>165</b>	<b>Black</b>	<b>SCEX1165</b>
Fox 7" long main spring (rear)			
	<b>300</b>	<b>Red</b>	<b>SCEX1300</b>
	<b>315</b>	<b>Yellow</b>	<b>SCEX1315</b>
	<b>330</b>	<b>White</b>	<b>SCEX1330</b>
	<b>350</b>	<b>Red</b>	<b>SCEX1350</b>
	<b>375</b>	<b>White</b>	<b>SCEX1375</b>
	<b>400</b>	<b>Yellow</b>	<b>SCEX1400</b>
	<b>425</b>	<b>Blue</b>	<b>SCEX0425P</b>
	<b>450</b>	<b>Green</b>	<b>SCEX0450P</b>
	<b>475</b>	<b>Black</b>	<b>SCEX0475P</b>
	<b>500</b>	<b>Purple</b>	<b>SCEX0500P</b>
Fox 10" long main spring (rear)			
	<b>325</b>	<b>White</b>	<b>SCEX2325</b>
	<b>350</b>	<b>Yellow</b>	<b>SCEX2350</b>
	<b>375</b>	<b>Red</b>	<b>SCEX2375</b>
	<b>400</b>	<b>Black</b>	<b>SCEX2400</b>

**Spring rate chart for Cobra Fox quad shocks**

## Break-In Procedure

Your Cobra Motorcycle is a close-tolerance high performance machine and break-in time is very important for maximum life and performance. The ECX80 AC can be ridden hard after the first ½ hour break-in time but it is recommended that no adjustments are made to the carburetion or suspension until the full 8 hours of bike break-in has elapsed. Also, after the engine, transmission, and drive train have been broken-in for the full 8 hours, the bike will be faster!

Use a fuel / oil mixture of 32:1 for the full 8 hour break-in period. Be sure to use 93 octane pump gas, or *Sunoco MO2<sub>x</sub>*, with Cobra's specially formulated *Cobra Venom 2-cycle Race Oil*. (Part # MCMUOL02)

### **CAUTION:**

Failure to use proper fuel or oil may result in premature engine wear, or damage to the machine.

Adhering to the following break-in schedule will result in long lasting high performance machine.

- First 5 minute period, operate the bike in neutral with a combination of idle and high RPM operation. (avoid prolonged high RPM rev it good at least once or twice per minute)
- Allow the engine to cool
- Ride for 15 minutes maximum, avoiding prolonged high RPM operation.
- Cool and inspect bike for loose fasteners.
- Next ½ hour of operation, avoid prolonged operation at Wide Open Throttle.
- After 1 hour of operation
  - Check for loose bolts and nuts on the bike and retighten as necessary (proper torque values are listed under Specifications).
  - Clean the carburetor bowl.
  - Change the transmission / clutch lubricant with *Cobra Power Shift Transmission Lubricant*
  - Replace the fuel filter.
- After 8 hours of operation have a Certified Cobra Mechanic change the shock oils.
- Your bike is now ready for the highest level of competition!

# Starting Procedure

Before starting the machine inspect the following:

- Insure that the fuel tank contains an adequate volume of fuel / oil mixture to complete the distance required. (93 octane pump gas with Cobra's specially formulated *Cobra Venom 2-cycle Race Oil*)
- Check for proper tire pressure in both tires.
- Observe the chain tension and adjust if necessary.
- Observe the coolant level and fill if necessary.
- Observe the level of lubricant in the transmission and add *Cobra Power Shift Transmission Lubricant* if necessary.
- Verify that the chain rollers do not have improper wear.
- Inspect the frame, for;
  - Cracks in the metal.
  - Cracking paint which might indicate overly stressed material.
- Verify that the handlebars are tight.
- Check the throttle for;
  - Smooth operation and sound closing.
  - Frayed strands of the cable inside the throttle housing.
- Check for loose bolts and nuts, and re-torque as necessary.
- Verify that the air filter is clean and properly saturated with oil.
- Turn the fuel on by rotating the fuel petcock knob to the vertically downward position (reserve position is horizontally inward).

## CAUTION:

For best results from your Cobra ATV use only the recommended fuels. Testing has shown that most 'race' fuels actually degrade performance.

When your pre-ride inspection is complete the bike may be started. For a cold engine follow this procedure.

1. Reaching down to the carburetor, on the left side of the bike, push down on the black choke lever.
2. Kick start the engine.
3. Rev the engine in short spurts, turning the throttle no more than 1/4 open until the engine will run without the choke.
4. Verify a functional engine shut-off switch by shutting off the engine.
5. Restart the engine and proceed with riding when the engine is sufficiently warm (i.e. the side of the cylinder is warm to touch).

## CAUTION:

Never rev an engine full throttle when it's cold or slightly warmed up. Cobra recommends that you tell your child to take it easy the first couple of minutes in practice until the engine comes up to full operating temperature. Make sure your engine is properly warmed up before racing.

# General Tips

1. Always wear a **helmet** and other **protective riding gear**.
2. Cobra recommends that you tell your child to take it easy the first couple of minutes in practice until the engine comes up to full **operating temperature**.
3. Make sure your riders' foot is not resting on the **rear brake** pedal while they are riding.
4. Evaluate the bikes **jetting** only after it has been warmed up to race temperatures.
5. A **properly maintained** machine is safer, faster, and more fun to ride.
6. When **washing the bike**, be careful to not directly aim the hose at the air filter area.
7. Make sure that there is adequate free play in both the **front lever and rear brake pedal**.
8. Your Cobra ATV has a 10 digit VIN (Vehicle Identification Number). The first three digits indicate the model and the seventh indicates the model year (MY).
  - a. Example, ECXxxx7xxx is a 2007 MY ECX70.

# Maintenance

## Schedule & Tips

It is important that you adhere to this maintenance schedule so as to promote the longevity of your Cobra Motorcycle.

- Between each ride
  - Inspect the fuel filter for contaminates.
  - Check the air filter (clean and re-oil as necessary).
  - Insure the smooth operation of the throttle cable (throttle soundly 'clacks' shut).
  - Check for frayed strands of the throttle cable inside the throttle housing and replace if necessary.
  - Check for adequate tire pressures and adjust if necessary.
  - Check all nuts and bolts for proper torque and re-torque if necessary.
  - Spray all moving parts with WD40 or other light oil.
  - Check drive chain for
    - Proper tension and adjust if necessary.
    - Adequate lubrication and lubricate if necessary.
  - Check the frame for cracks in the metal or cracks in the paint that might indicate that the metal has been stressed beyond it's safe limits. Replace or get properly rewelded as necessary.
- Every 2 hours of operation
  - Replace the transmission oil with *Cobra Power Shift Transmission Lubricant*.
- Every 10 hours of operation
  - Have the shock oil replaced by a Certified Cobra Mechanic.

### CAUTION:

1. If you ever need to weld anything on the bike, disconnect the spark plug cap, unplug the ignition, disconnect the kill switch, scrape the paint bare near the area to be welded and put the ground clamp as close to the area to be welded as possible.

### WARNING

Be sure the fuel tank and carburetor have been removed and safely located away from the welding process.

2. The frame is a low carbon alloy tubing and it is important to weld it with the proper rod and heat settings set as light as possible. Cobra recommends replacing the frame with a new one if the old one becomes damaged.

# M1: Replacing Transmission Lubricant

## Tools needed:

- 530 ml (18 oz) *Cobra Power Shift Transmission Lubricant*
- large flat blade screwdriver
- 13 mm wrench or socket

## Procedure:

1. Begin this procedure with a bike that has been ridden more than 5 minutes but less than 10 minutes. It is desired to have the engine warm enough so that the oil 'runny' but not so hot that there is risk of being burned by the engine or the oil.

### **WARNING**

Hot oil and hot components on the motorcycle may cause burns.

2. Lean bike against something or set on stand with oil drain hole.
3. Using the 13 mm wrench, remove the oil drain bolt located on the right side of the engine (figure 1).

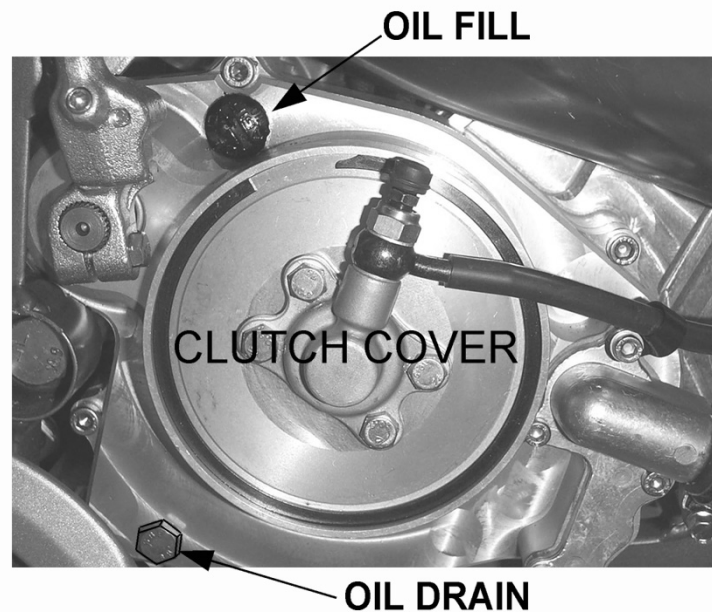

Figure 1

4. After it has drained, reinstall the drain screw with gasket.
5. Remove the oil fill plug and pour in 530 ml (18 oz) 85W 90 gear lubricant.

**NOTE:** Leaning the bike over onto its left hand side will facilitate the oil filling procedure.

6. Reapply the oil fill screw, securely, being sure the gasket is in place.

## M2: Chain adjustment

### Tools needed:

- 13 mm wrench or socket
- 5mm pin (Screw driver or hex key will do)

### Procedure:

1. Loosen the eccentric housing on the swingarm with two 13mm tools.
2. Stick the 5mm pin through the sprocket into the eccentric hole.
3. Push the quad forward or backward, turning the wheels (i.e. the sprocket) in the direction shown until the desired chain tension is achieved (see fig. 2).

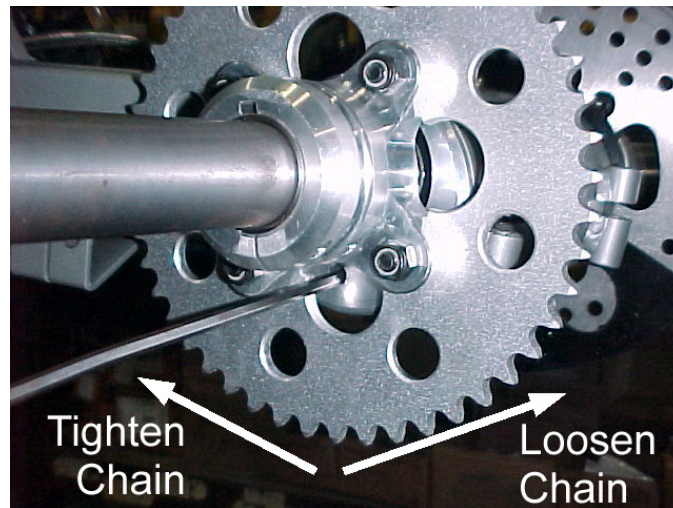

Figure 1

### NOTE:

The location of the pin hole is the 'fattest' part of the eccentric. Restated, if the pin hole is all the way forward, the chain is as tight as possible, and if the pin hole is all the way back, the chain is as loose as possible.

### CAUTION:

Proper chain tension allows no less than ½" (12mm) free play through out the range of rear suspension travel.

### NOTE:

It may be handy to set backwards on the seat and feel the chain as you weight, and unweight, seat to feel for chain free play.

4. After achieving the proper adjustment retighten the two eccentric pinch bolts.

### CAUTION:

Be sure to remove the pin from the eccentric before riding.

## M3: Air Filter Cleaning

This Cobra Motorcycle comes with a unique air filter / air boot unit designed to facilitate motorcycle service.

### Tools recommended for air filter maintenance:

- Screwdriver
- Foam filter oil

### Procedure

1. Removed the filter from the carburetor.
2. Clean the filter with cleaning solvent and then again with hot soapy water.
3. Allow it to dry thoroughly.
4. Saturate with foam filter oil and remove excess.

### WARNING

Do not clean the air filter with gasoline or other highly volatile petroleum product. Cleaning solvent, diesel fuel, or kerosene would be preferred but caution should still be taken.

### NOTE:

The biodegradable air filter oils, greases, and cleansers work acceptably with this Cobra Motorcycle.

### NOTE:

It is very important to keep the air filter clean and properly oiled with high quality water-resistant foam filter oil. It's very important to oil your filter consistently each time because varied amounts of oil will change your carburetor jetting.

### NOTE:

Make sure you change or clean your filter after each moto or significant ride. We recommend carrying three or more filters in your toolbox.

- 1 for practice
- 1 for each moto

### CAUTION:

Dusty conditions will require more frequent cleaning.



## M4: Front end

### Toe in adjustment

Riders and parents have provided feedback that they prefer the toe in adjustment between  $\frac{1}{2}$ " (12mm) out to  $\frac{1}{2}$ " (12mm) in. This is set by adjusting the length of the tie rod assemblies. See figure 3 for direction of turn.

#### **⚠ WARNING**

Adjust both wheels so that they have the same amount of toe in.

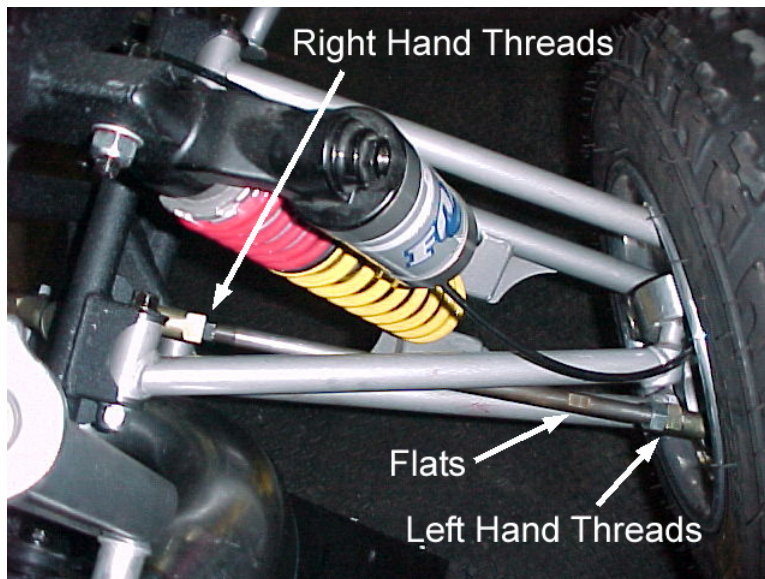

Figure 3

### Steering

The unique Cobra front end will exhibit some free play from the factory and that the seals (it that's what you want to call them) will fall out after the first ride. We have found that this causes no adverse effects and that the looseness does not get significantly worse as long as the bearings are sprayed with a spray lubricant (WD40 or similar) upon each ride.

# Parts

## Parts – Air Inlet System

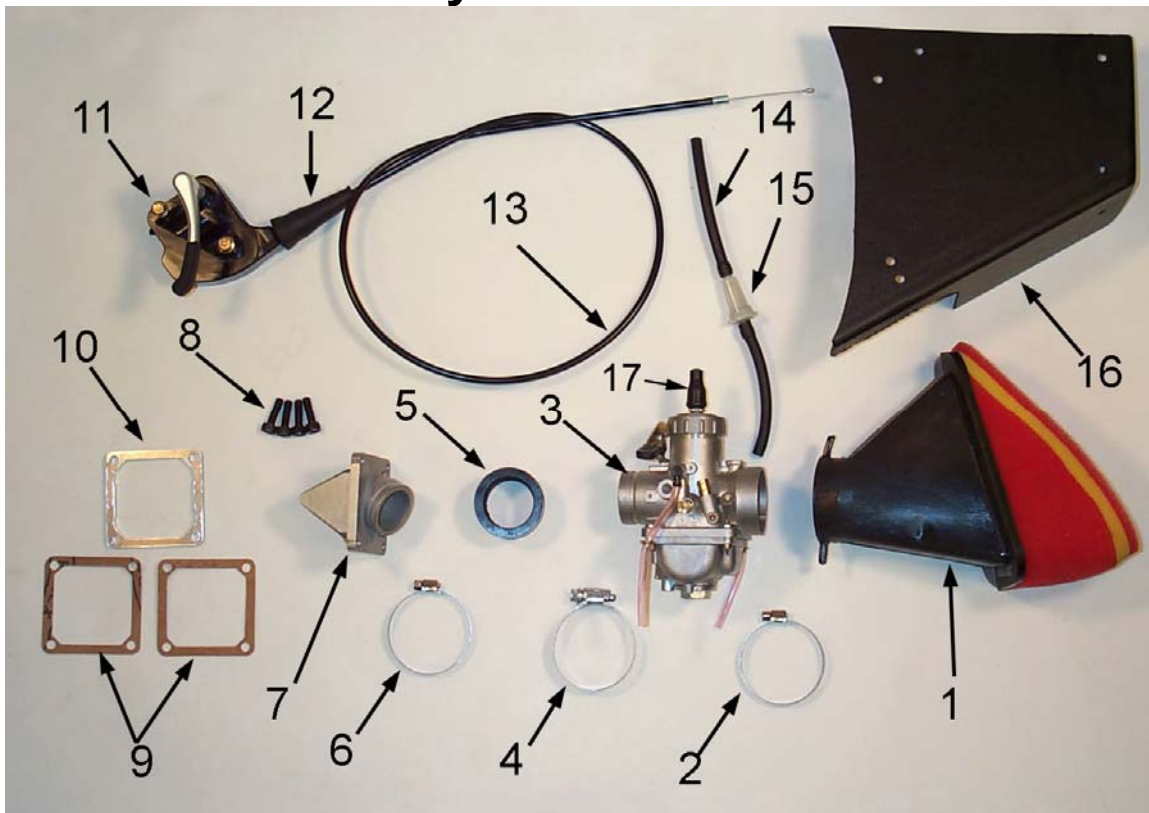

Figure 4

Coolant System		
REF #	PART #	DESCRIPTION
1	RCDC0001	AIR FILTER ASSEMBLY
2	MCKGHO03	HOSE CLAMP – FILTER TO CARB
3	RAEX0026	CARBURETOR 26MM MIKUNI VM
4	MCMUCL10	HOSE CLAMP – CARB TO INLET BOOT (WIDE)
5	ECEX0012	INLET BOOT
6	MCMUCL03	HOSE CLAMP – BOOT TO REED MANIFOLD (NARROW)
7	ECDC0094	INLET MANIFOLD WITH REED ASSEMBLY
		REEDS - REPLACEMENT STOCK
	ECDCRD15	REEDS – SOFT
8	HCBC0602	M6 X 20 SOCKET HEAD CAP SCREW (4 REQ'D)
9	ECDC0093	GASKET – INLET (2 PLACES)
10	RCMU0001	SPACER – REED
11	FCEX0016	THROTTLE, QUAD THUMB STYLE
12	FCPW0004	THROTTLE CABLE END GROMMET
13	RCEX0002	CABLE - THROTTLE
14	RCE50001	FUEL LINE 5 INCH
15	FCDC0093	FILTER, FUEL
16	RCEX0019	COVER, AIR FILTER
17	RCMU0415	CABLE ADJUSTER CAP
	RCMU0022	CARBURETOR VENT HOSE

## Parts – Bars and Steering

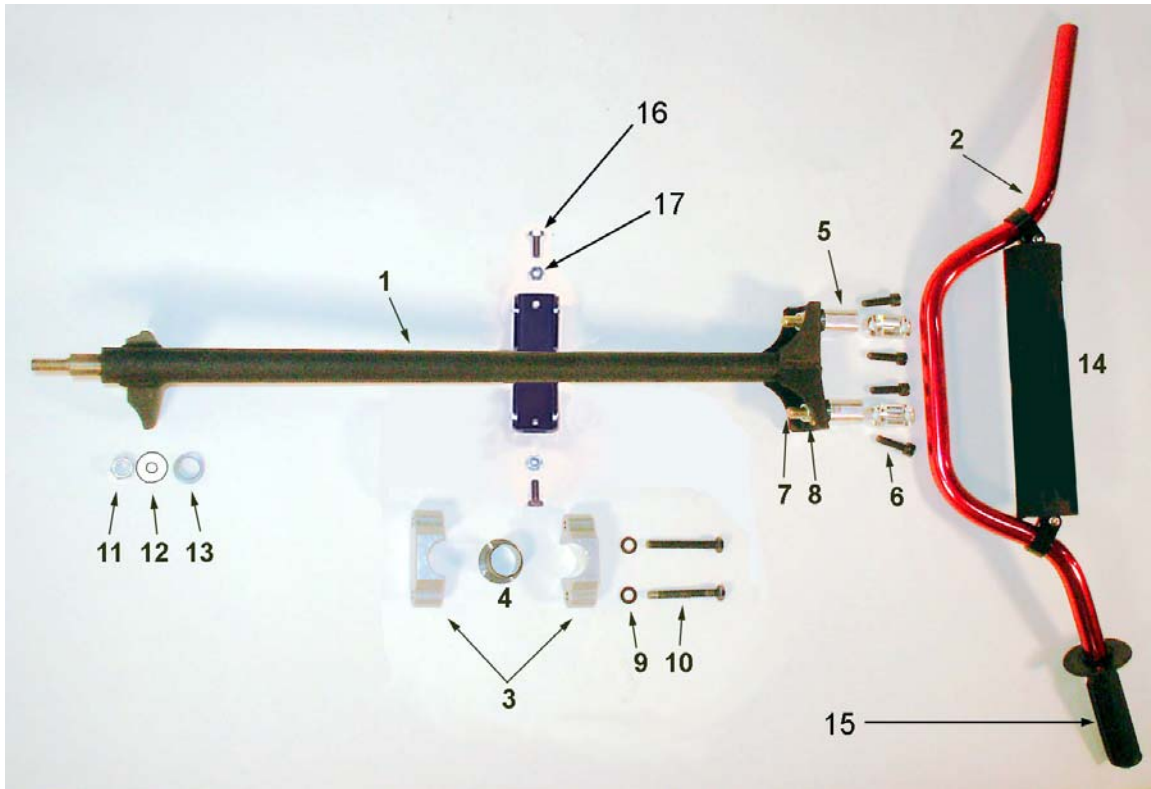

Figure 5

Bars and Steering		
REF #	PART #	DESCRIPTION
1	FAEX0020	STEERING STEM
2	TCMU0009	HANDLEBAR - QUAD
3	FCEX0011	STEERING STEM BLOCK (2 REQ'D)
4	MCEXBR07	STEERING STEM BUSHING – SPLIT
NOT SHOWN	ZCEX0002	O'RING – STEERING STEM SEAL (2 REQ'D)
5	TCMU0404	BAR MOUNT KIT, SHORT – REPLACEMENT (2 REQ'D)
NOT SHOWN	TCMU0403	BAR MOUNT KIT, TALL – OPTIONAL (2 REQ'D)
6	HCBC0806	SOCKET HEAD CAP SCREW M8 X 30 (4 REQ'D)
7	HCBC1001	M10X45 SOCKET HEAD CAP SCREW (2 REQ'D)
8	HCNL1001	M10 LOCK NUT (2 REQ'D)
9	HCWF0801	8MM FLAT WASHER
10	HCBH0810	8MM X 65 HEX HEAD BOLT (2 REQ'D)
11	HCNL1001	10MM LOCK NUT
12	HCWF0010	10MM FLAT WASHER
13	MCEXBR04	STEM PIVOT BUSHING - LOWER
14	MCMU0001	CROSS BAR PAD
15	TCEX0013	GRIPS SET OF TWO
16	HCBH0601	6MM X 16 HEX HEAD BOLT (2 REQ'D)
17	HCNS0601	6MM NUT (2 REQ'D)

## Parts – Bumper, Nerf & Grab Bars

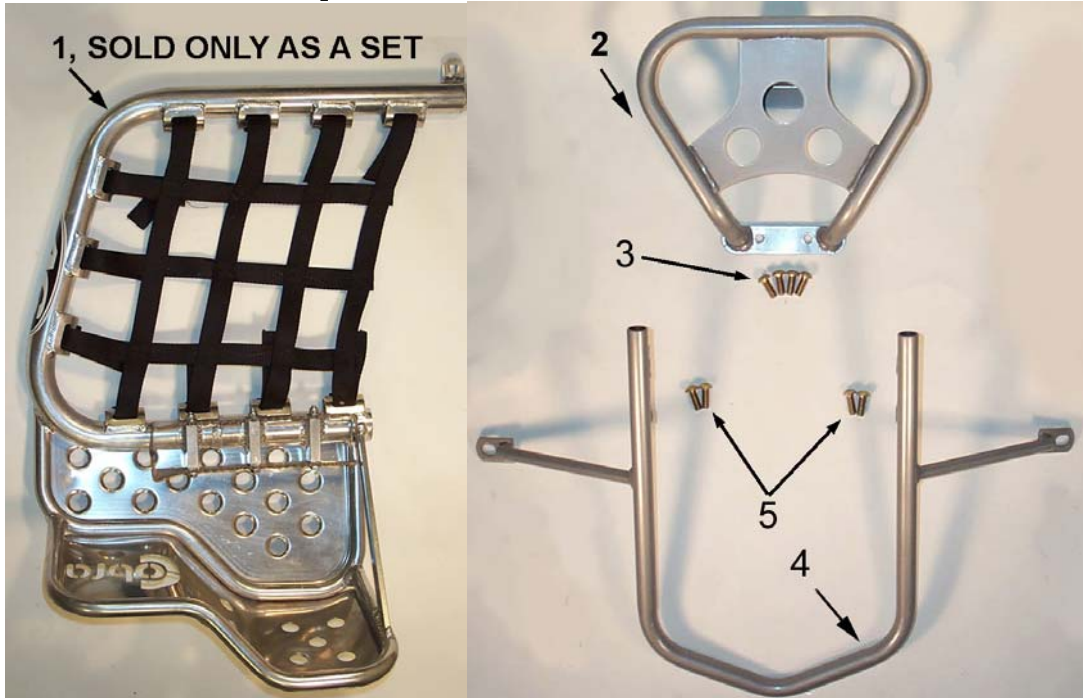

Figure 6

BODY PROTECTION		
REF #	PART #	DESCRIPTION
1	FCEX0024	NERF BARS (LEFT & RIGHT)
	FCEX0067B	NERF NET SET (BLACK)
	FCEX0067R	NERF NET SET (RED)
	FCEX0067Y	NERF NET SET (YELLOW)
NOT SHOWN	HCBH0808	8MM X 30 HEX HEAD BOLT (FRONT MOUNT, 2 PLACES)
NOT SHOWN	HCBH0809	8MM X 50 HEX HEAD BOLT (REAR MOUNT, 2 PLACES)
NOT SHOWN	HCWF0801	8MM FLAT WASHER (2 REQ'D)
NOT SHOWN	HCNL0801	8MM LOCKNUT (2 REQ'D)
2	FAEX0099	FRONT BUMPER
3	HCBB0802	M8 X 20 BUTTON HEAD BOLT (4 REQ'D)
4	FCEX0003	GRAB BAR
5	HCBC0820	M8 X 20 SOCKET HEAD CAP SCREW (4 REQ'D)

# Parts – Carburetor

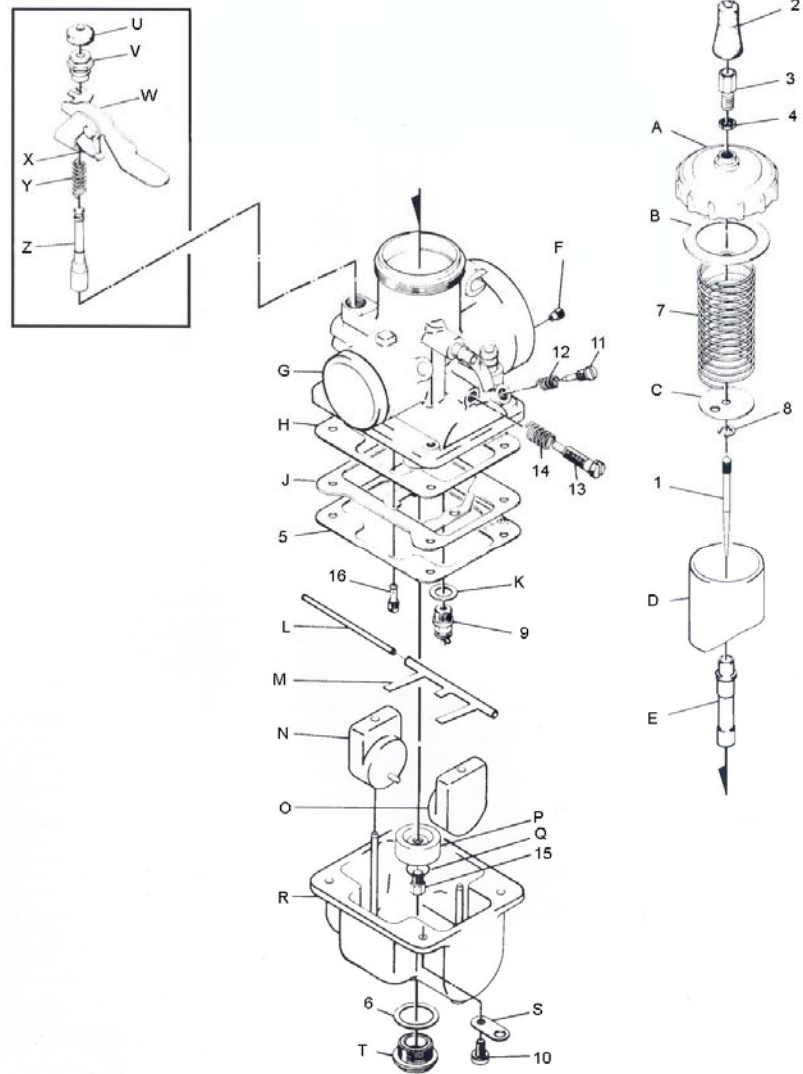

Figure 7

Carburetor accessories		
REF #	PART #	DESCRIPTION
	RAEX0026	CARBURETOR, 26MM MIKUNI VM
	RCEX0001	CABLE, THROTTLE
1	RCEX0017	JET NEEDLE (5F21) STANDARD
	RCEX0018	JET NEEDLE (5F3)
2	RCMU0415	CABLE ADJUSTER CAP
3	RCEX0005	ADJUSTER, THROTTLE CABLE
4	RCEX0006	LOCK NUT, THROTTLE CABLE ADJUSTER
5	RCEX0007	GASKET, CARBURETOR BOWL
6	RCEX0008	PLUG WASHER, MAIN JET
7	RCEX0009	SPRING, THROTTLE VALVE
8	RCEX0010	E-CLIP, NEEDLE
9	RCEX0011	NEEDLE VALVE, SEAT ASSEMBLY
10	RCEX0012	SCREW, FLOAT BOWL
11	RCEX0013	SCREW, AIR ADJUSTING
12	RCEX0014	SPRING, AIR ADJUSTING SCREW
13	RCEX0015	SCREW, IDLE ADJUSTING
14	RCEX0016	SPRING, IDLE ADJUSTING SCREW
15	RCMU0xxx	MAIN JET, xxx DENOTES SIZE (170, 175, 180, 185, 190, 195, 200, 205, 210)
16	RCEX00xx	PILOT JET, xx DENOTES SIZE
	REMU0022	VENT HOSES

# Parts – Clutch Actuation

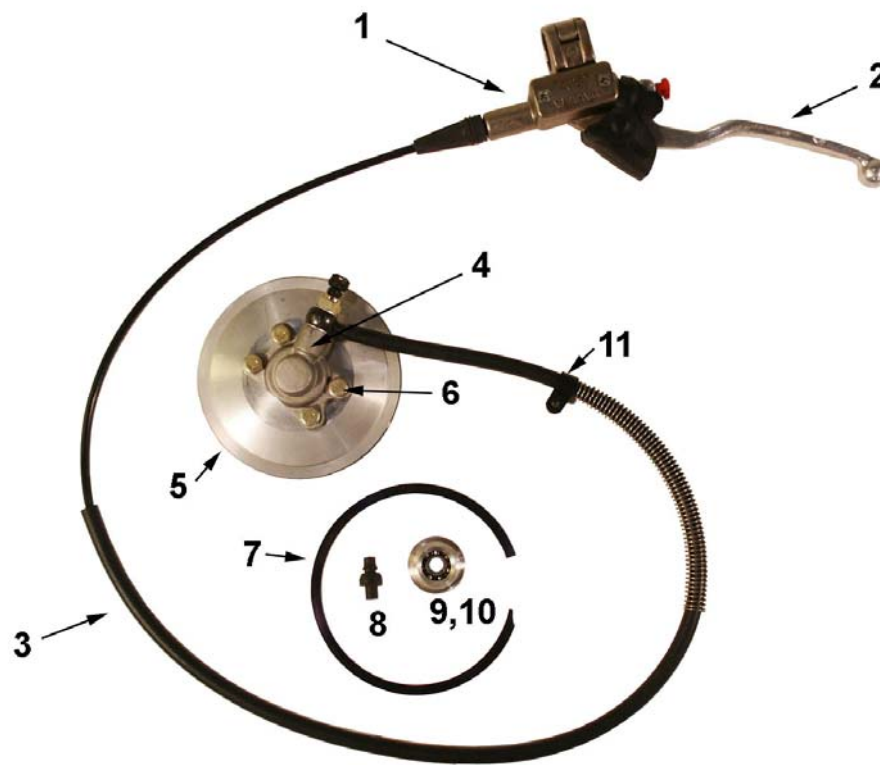

Figure 8

Clutch Actuation		
REF #	PART #	DESCRIPTION
	CADC0001	CLUTCH ACUTATOR ASSEMBLY (Lever, Master Cyl., Line, Slave Cyl.)
1	CCMU0004	MASTER CYLINDER
2	CCDC0001	CLUTCH LEVER
3	FCEX0020	CLUTCH LINE
4	CCDC0002	CLUTCH SLAVE CYLINDER
5	ECDC0074	CLUTCH CAP
6		M6 x 16 Bolt
7	ECDC0082	SNAP RING – CLUTCH CAP
8	ECDC0020	CLUTCH PUSH ROD
9	ECDC0018	CLUTCH THROW-OUT BEARING
10	ECDC0019	CLUTCH BEARING SEAT
11	HCCC0002	CABLE CLAMP
NOT SHOWN	ZCDCOR05	CLUTCH CAP O-RING
NOT SHOWN	ZCDCOR04	SLAVE CYLINDER O-RING

# Parts – Coolant System

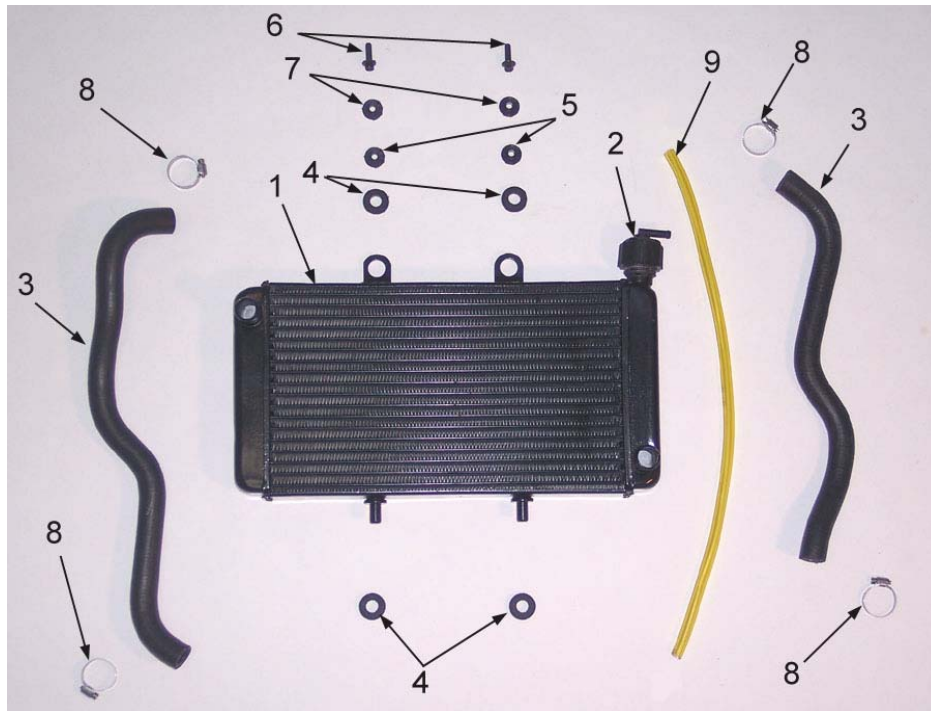

Figure 9

Coolant System		
REF #	PART #	DESCRIPTION
1	FCEX0066	RADIATOR WITH CAP
2	FCMU0020	RADIATOR CAP
3	ECEX0010	RADIATOR HOSE
4	MCEXGR01	GROMMET, RAD MOUNT (4 REQ'D)
5	MCMUGR04	GROMMET, TOP RAD MOUNT (2 REQ'D)
6	HCBF0620	FLANGE HEAD BOLT M6X20 (2 REQ'D)
7	HCWF1478	WASHER RADIATOR MOUNTING
8	MCMUCL07	HOSE CLAMP (4 REQ'D)
9	FCMU0049	RADIATOR OVERFLOW HOSE
Not Shown	MCMUCL05	HOSE CLAMP, OVERFLOW HOSE

# Parts – Electrical System

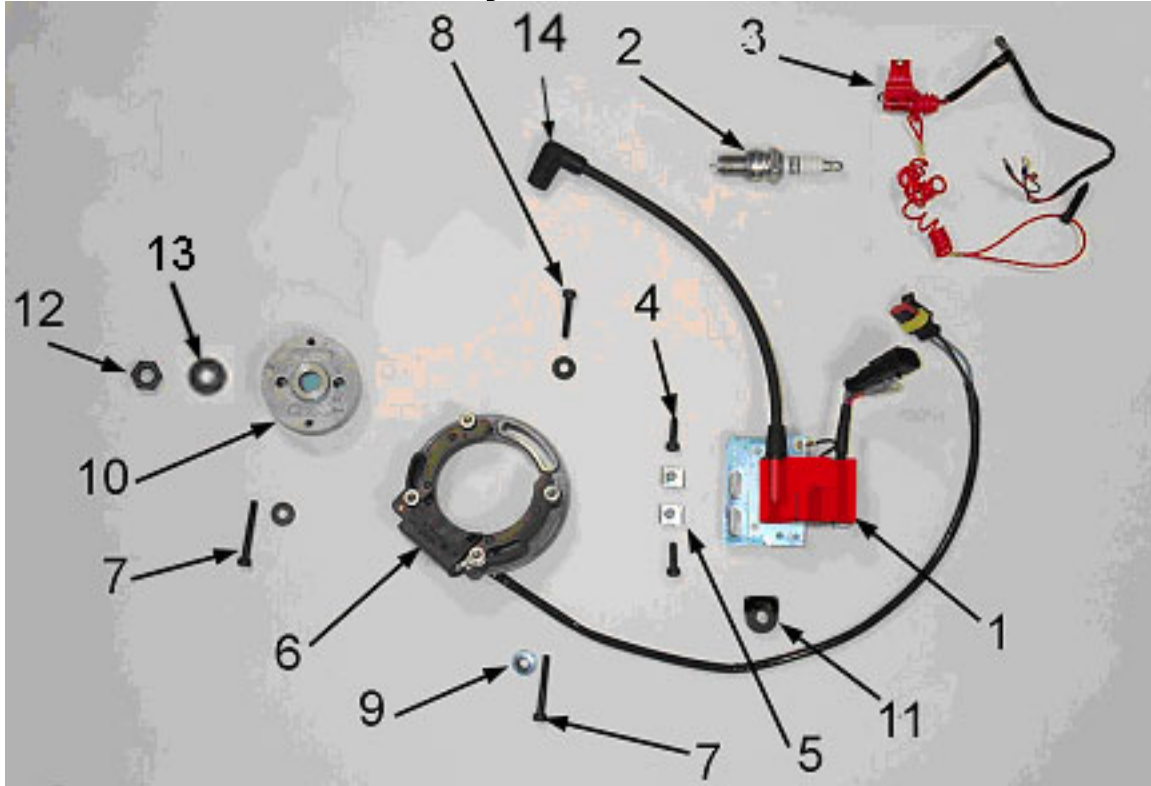

Figure 10

Electrical System		
REF #	PART #	DESCRIPTION
1	ICMU0013	COIL (3 WIRE DIGITAL)
2	ECMU0065	SPARK PLUG, CHAMPION (8339-1)
2H	ECMU0067	OPTIONAL HOTTER PLUG (8332-1)
2C	ECMU0066	OPTIONAL COLDER PLUG (8904-1)
3	IKEX0001	IGNITION KILL TETHER
4	HCBC0516	SCREW, M5 X 16 (2 PER)
5	HCCN0000	5MM CLIP NUT (2 PER)
6	ICMU0018	STATOR 3 WIRE W/ GROMMET
7	HCBC0535	5mm x 35 SOCKET HEAD CAP SCREW (2 REQ'D)
8	HCBC0525	5mm x 25 SOCKET HEAD CAP SCREW
9	HCWF0504	WASHER FOR STATOR (3 REQ'D)
10	ICMU0006	ROTOR
11	ICMUGR01	GROMMET - STATOR LEAD
12	HCNS1001	NUT 10MM
13	HCWF0038	WASHER - FLYWHEEL
14	ICMU0016	SPARK PLUG CAP RESISTIVE
NOT SHOWN	ICMU0012	WOODRUFF KEY
NOT SHOWN	ECDC0085	IGNITION COVER
NOT SHOWN	ZCDC0004	GASKET, IGNITION COVER



# Parts – Engine Clutch

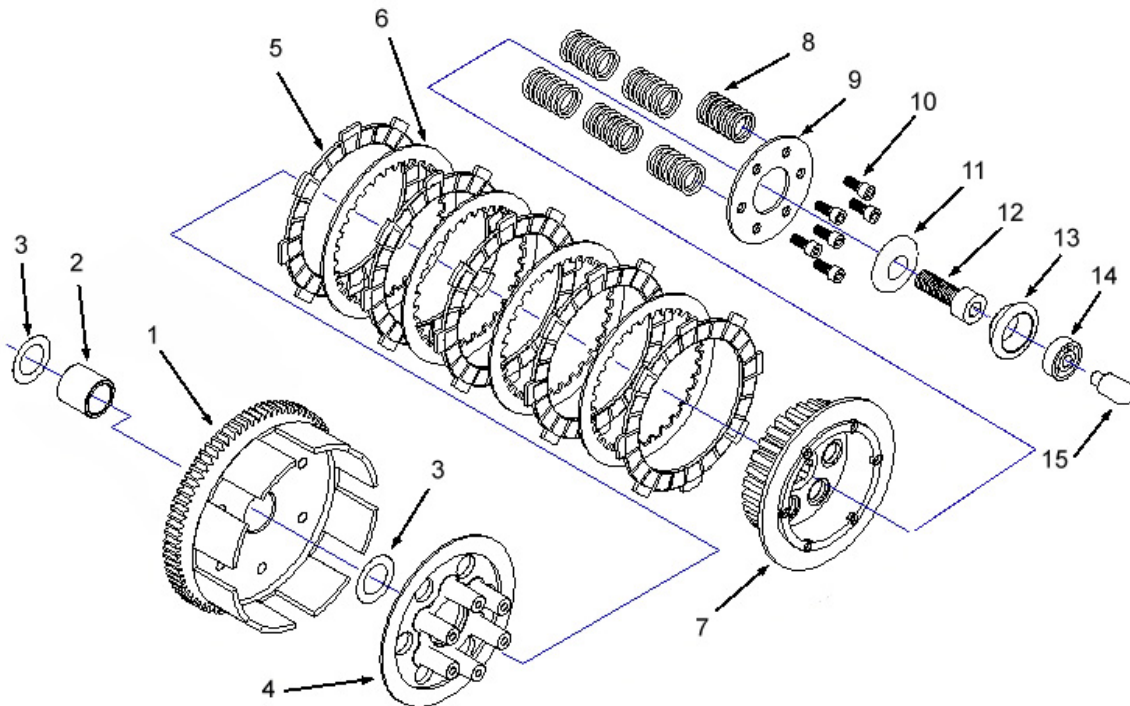

Figure 11

Clutch components		
REF. #	PART #	DESCRIPTION
1	EAEX0003	CLUTCH BASKET ASSEMBLY
2	ECDC0064	CLUTCH BUSHING – INNER / STEEL
NOT SHOWN	ECDC0167	CLUTCH BUSHING - OUTER / BRONZE
3	ECDC0063	CLUTCH WASHER (2 PLACES)
4	ECDC0066	CLUTCH PRESSURE PLATE
5	ECDC0068	CLUTCH DISC-FRICTION – (5 REQ'D)
6	ECDC0067	CLUTCH DISC-STEEL – (4 REQ'D)
7	ECDC0069	CLUTCH HUB
8	ECDC0070	SPRING, CLUTCH – (6 REQ'D)
9	ECDC0224	PLATE, CLUTCH SPRING
10	HCBC0525	5X25 SOCKET HEAD CAP SCREW (6 REQ'D)
11	ECDC0030	SPRING WASHER – CLUTCH
12	HCBC1035	10MM X 35 SHCS BLACK OXIDE
	HCBF1035	10MMX35 FLANGE HEAD BOLT
13	ECDC0019	CLUTCH BEARING SEAT
14	ECDC0018	BEARING,CLUTCH THROW OUT
15	ECDC0020	CLUTCH PUSH ROD

## Parts – Engine – Clutch / Kick Cover

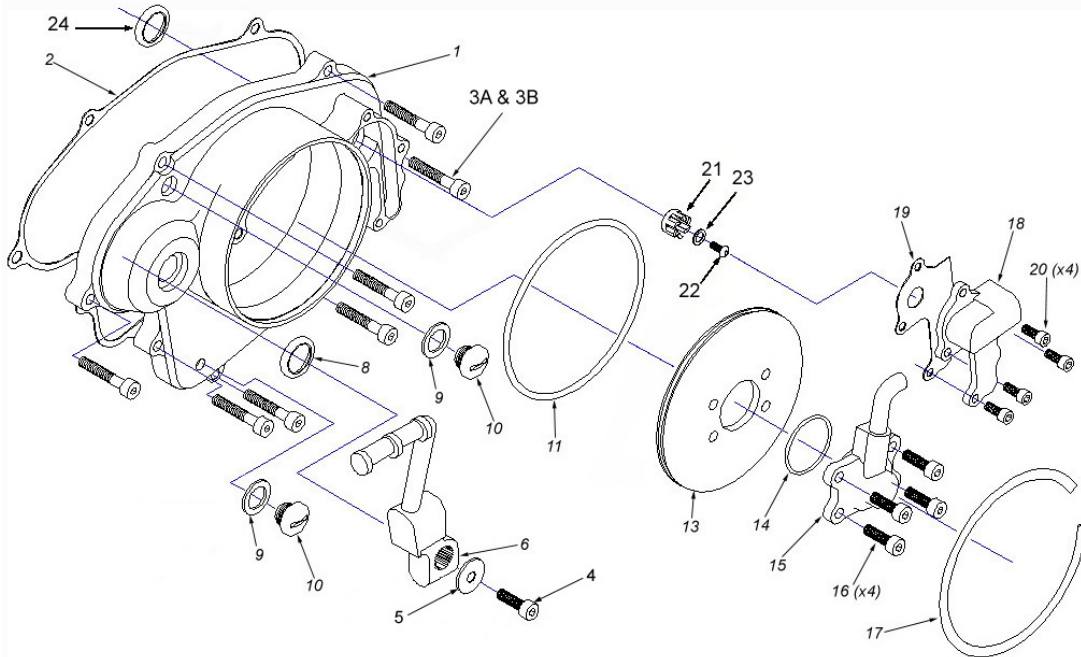

Figure 12

Clutch / kick cover components		
REF. #	PART #	DESCRIPTION
1	ECMU0150	CLUTCH COVER (07 STYLE)
2	ZCMU0014	GASKET-CLUTCHCOVER
3A	HCBF0625	6X25 SOCKET HEAD CAP SCREW (6 REQ'D)
3B	HCBF0630	6X30 SOCKET HEAD CAP SCREW (2 REQ'D)
4	HCBF0612	6X12 FLANGE HEAD BOLT
5	HCWF0618	WASHER - KICK LEVER
6	ECDC0046	KICKSTARTER LEVER
7	HCBB0625	SCREW M6X25 BUTTON HEAD
8	ECDC0078	SEAL,KICKSTARTER
9	ZCMU0005	GASKET-OIL FILL PLUG
10	ECMU0037	OIL FILL/DRAIN BOLT W/GASKET
11	ZCDCOR05	ORING-CLUTCH CAP
13	ECDC0074	CLUTCH CAP
14	ZCDCOR04	ORING,CLUTCH SLAVE CYLINDER
NOT SHOWN	CCEX0009	BALL, CLUTCH ACTUATOR
15	CADC0001	CLUTCH ASSEMBLY
16	HCBC0601	6X16 SOCKET HEAD CAP SCREW
17	ECDC0082	SNAP RING-CLUTCH CAP
18	ECAX0150	IMPELLER COVER
19	ZCC60004	GASKET-IMPELLER COVER <b>(may not be used)</b>
20	HCBC0601	6X16 SHCS
21	ECDC0075	IMPELLER, WATERPUMP
22	HCBC1512	M5 X 12 SHCS STAINLESS
23	HCWF0501	5MM FLAT WASHER
24	ECKG0074	SEAL, WATERPUMP
NOT SHOWN	ECMU0218	RETAINING RING, WATER PUMP SEAL

## Parts - Engine - Ignition Side

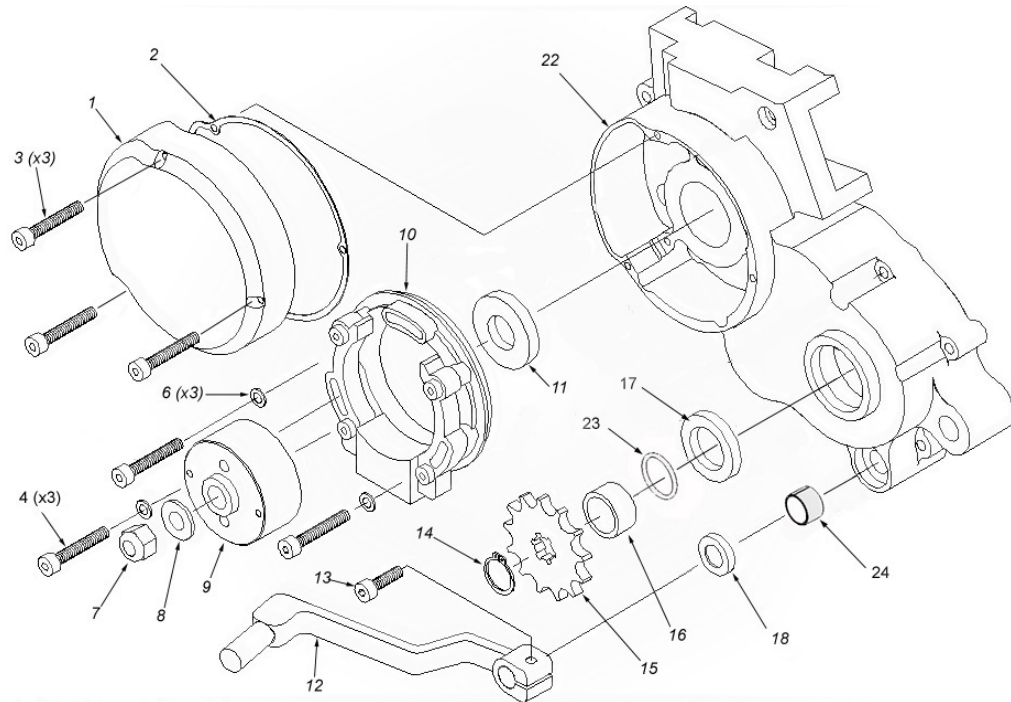

Figure 13

Ignition side engine components		
REF. #	PART #	DESCRIPTION
1	ECDC0085	IGNITION COVER
2	ZCDC0004	GASKET-IGNITION COVER
3	HCBC0402	4X35 SOCKET HEAD CAP SCREW (3 REQ'D)
4	HCBC0525	5X25 SOCKET HEAD CAP SCREW
5	HCBC0535	5X35 SOCKET HEAD CAP SCREW (2 REQ'D)
6	HCWF0501	WASHER FLAT 5MM
7	HCNS1001	NUT M10
8	HCWF0038	3/8 FLAT WASHER
9	ICMU0006	ROTOR
10	ICMU0018	STATOR - 3 WIRE
11	ECDC0024	SEAL, CRANKSHAFT
12	ECDC0087	SHIFTER LEVER
13	HCBH0620	M6 X 20 HEX HEAD BOLT
14	ECKGSR03	SNAP RING-OUTPUT-COBRA
15	PCKG00xx	SPROCKET xx denotes number of teeth
16	ECDC0009	SPACER, SPROCKET
17	ECDC0025	SEAL, OUTPUT
18	ECDC0026	SEAL, SHIFTER
	ICMUGR01	GROMMET-IGNITION
22	EKEX0089	ENGINE CASE SET OF LEFT & RIGHT
23	ZCDCOR01	O-RING, SPROCKET SPACER
24	ECEX0008	BUSHING, SHIFTER SHAFT

## Parts - Engine – Kick Mechanism

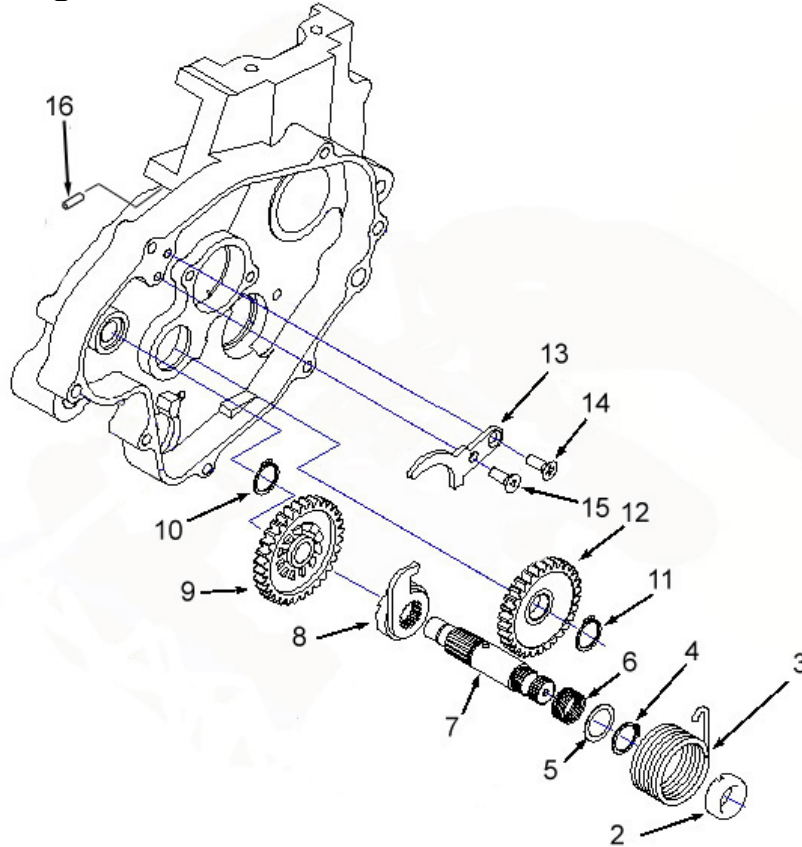

Figure 14

Kick Mechanism		
REF. #	PART #	DESCRIPTION
	EKEX0089	ENGINE CASE SET OF LEFT & RIGHT
1	ECDC0107	SPLASH GUARD
2	ECDC0111	SPACER, KICK START SHAFT
3	ECDC0040	SPRING, KICKSTART RETURN
4	ECDC0036	SNAP RING, EXTERNAL 16MM
5	ECDC0043	WASHER, KICKSTART BACKUP
6	ECDC0042	SPRING, KICKSTART RAMP
7	ECMU0135	SHAFT, KICK START
8	ECDC0038	RAMP GEAR, KICKSTART
9	ECDC0033	GEAR, KICKSTART
10	ECDC0035	SNAP RING, EXTERNAL 12MM
11	ECDC0037	SNAP RING, EXTERNAL 15MM
12	ECDC0032	GEAR, KICK START IDLE
13	ECDC0039	RAMP, KICK START
14	ECDC0060	6MM X 16 PHILLIPS FLAT HEAD SCREW
15	HCB1612	6MM X 12 MM BUTTON HEAD BLACK OXIDE
16	ECMU0533	FITTING, VENT HOSE
NOT SHOWN	ECMU0534	VENT HOSE

## Parts – Engine – Shift Mechanism

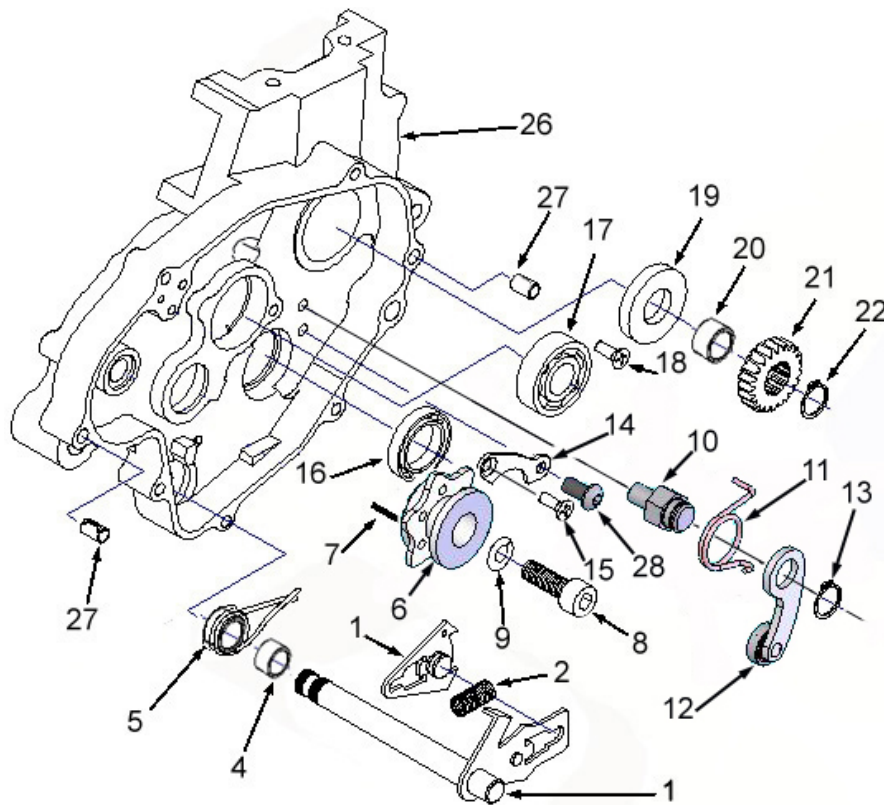

Figure 15

Clutch components		
REF. #	PART #	DESCRIPTION
1	EADC0154	SHIFTER SHAFT (2 COMPONENTS) W/SPRING
2	ECDC0055	SPRING - SHIFTER SHAFT
4	ECDC0110	SPACER, CENTERING SPRING
5	ECDC0099	SPRING, CENTERING
6	ECMU0550	SHIFT CASSETTE (W/O PINS)
7	ECDC0051	DOWEL – SHIFT DRUM INDEX
8	HCBC1825	8MM X 25 SHCS BLACK OXIDE
9	HCWL0802	8MM LOCKWASHER, HI COLLAR
10	ECMU0548	PIVOT, SHIFT ARM
11	ECMU0546	SPRING, SHIFT FOLLOWER ARM
12	ECMU0545	ARM ASSY, SHIFT FOLLOWER
13	ECDC0035	CLIP, ARM RETAINER
14	ECDC0056	BEARING RETAINER PLATE
15	ECDC0060	6MM X 16 FLAT HEAD PHILLIPS SCREW
16	ECDC0022	BEARING, SHIFT DRUM
17	ECMU0216	BEARING, PRIMARY SHAFT CLUTCH SIDE
18	HCBB1612	6MM X 12 BUTTON HEAD BLACK OXIDE
19	ECDC0024	SEAL, CRANKSHAFT
20	ECDC0112	SPACER, CRANK DRIVE GEAR
21	ECDC0073	CRANK DRIVE GEAR
22	ECDC0036	SNAP RING, EXT 16MM
26	EKC62008	ENGINE CASE SET W/B&S CX65 08
27	ECDC0031	DOWEL, HOLLOW (2 PLACES)
28	HCBB1612	6MM X 12 BUTTON HEAD

## Parts – Engine – Top End

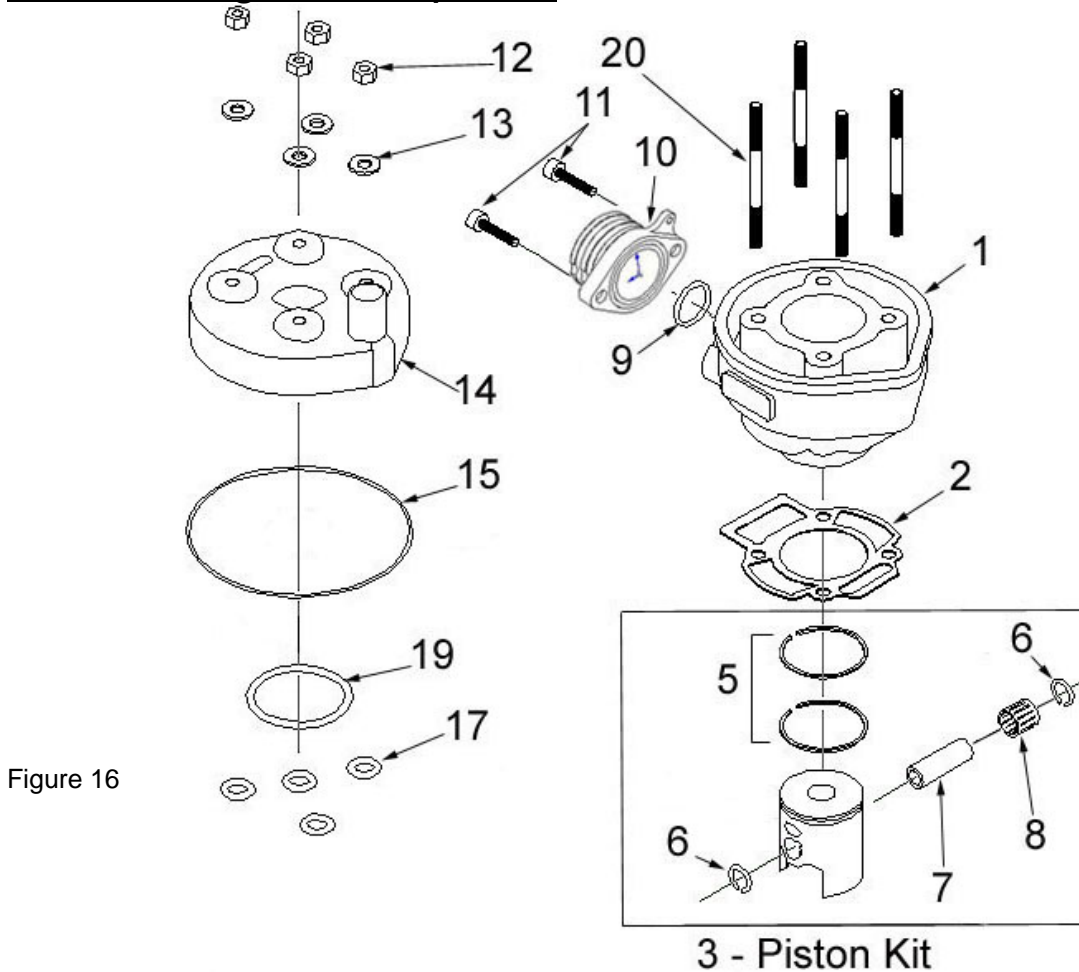

Figure 16

### 3 - Piston Kit

Engine – Top End		
REF #	PART #	DESCRIPTION
1	ECE80002	CYLINDER KIT (INCLUDES PISTON KIT)
2	ZCKG0501	BASE GASKET 0.015" (0.4mm thick) For other Base Gaskets refer to <b>Base Gasket Selection</b> section of this manual
3	ECE90002x	PISTON KIT (xx denotes piston size, A, or AB, etc...)
5	ECE90004	PISTON RING
6	ECMUSR00	SNAP RING FOR PISTON (2 REQ'D)
7	ECDC0090	WRIST PIN
8	ECDC0061	BEARING, WRIST PIN
9	ZCMUOR07	O-RING, EXHAUST FLANGE
10	ECMU0074	EXHAUST FLANGE
NOT SHOWN	ZCMOTE11	O-RINGS – PIPE TO FLANGE (2 REQ'D)
11	HCBC0612	M6X12, EXHAUST FLANGE SCREW (2 REQ'D)
12	HCNS0702	7MM NUT HIGH STRENGTH
13	HCWS1401	FLAT WASHER - HARDENED
14	ECE90006	CYLINDER HEAD 1 PIECE INNER / OUTER
15	ZCMUOR02	O-RING, CYLINDER HEAD LARGE
17	ZCMUOR10	O-RING CYLINDER STUD (4 REQ'D)
19	ZCE90001	O-RING CYLINDER HEAD MEDIUM (1 PIECE HEAD)
20	ECMU0147L	STUD, CYLINDER 7mm LONG

# Parts - Engine - Transmission

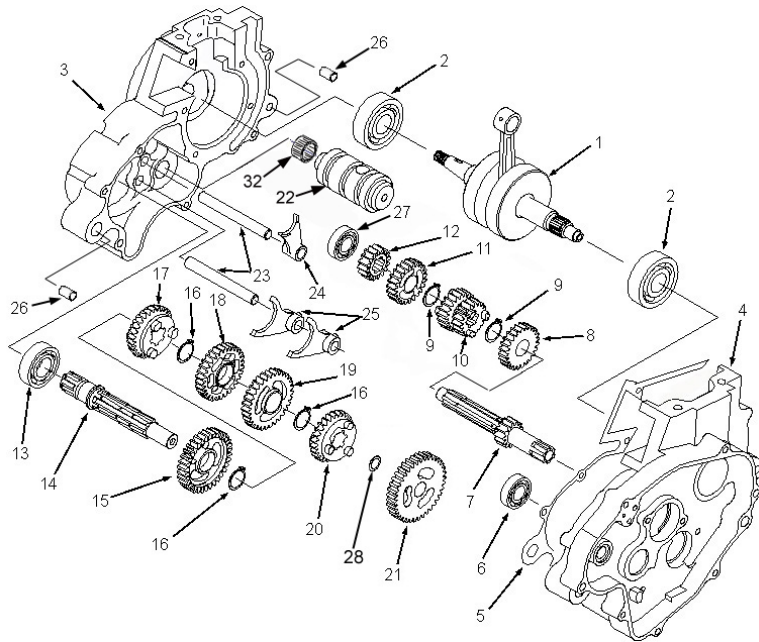

Figure 17

Transmission		
REF #	PART #	DESCRIPTION
1	ECEX0015	CRANKSHAFT, '09
ACCESSORY	EKEX0001	ROD KIT
2	ECDC0023	BEARING, CRANKSHAFT
3	EKEX0089	ENGINE CASE SET OF LEFT & RIGHT
4	EKEX0089	ENGINE CASE SET OF LEFT & RIGHT
5	ZCEX0004	GASKET, CRANKCASE CENTER, '08
Left Case Screws	HCBC0604	6X35MM SOCKET HEAD CAP SCREW (4 REQ'D)
Right Case Screws	HCBC0603	6X30MM SHCS (7 REQ'D)
Right Case Screws	HCBC0607	6X50 SHCS
6	ECDC0021	BEARING, OUTPUTSHAFT CLUTCH SIDE
7	ECDC0001	SHAFT, TRANSMISSION PRIMARY (1 <sup>ST</sup> GEAR), 13T
8	ECDC0002	GEAR, 6 <sup>TH</sup> PRIMARY 24T
9	ECDC0003	SNAP RING, EXTERNAL 17 MM (2 REQ'D)
10	ECDC0004	GEAR, 3 <sup>RD</sup> /4 <sup>TH</sup> PRIMARY, 18/21T
11	ECDC0005	GEAR, 5 <sup>TH</sup> PRIMARY, 23T
12	ECDC0006	GEAR, 2 <sup>ND</sup> PRIMARY, 16T
13	ECKGBR01	BEARING, OUTPUT IGNITION SIDE
14	ECDC0007	SHAFT, TRANSMISSION OUTPUT
15	ECDC0014	GEAR, 2 <sup>ND</sup> OUTPUT, 31T
16	ECDC0017	SNAP RING, EXTERNAL 18MM (3 REQ'D)
17	ECDC0013	GEAR, 5 <sup>TH</sup> , OUTPUT, 30T
18	ECDC0011	GEAR, 4 <sup>TH</sup> OUTPUT, 28T
19	ECDC0010	GEAR, 3 <sup>RD</sup> OUTPUT, 34T
20	ECDC0015	GEAR, 6 <sup>TH</sup> OUTPUT, 26T
21	ECDC0016	GEAR, 1 <sup>ST</sup> OUTPUT, 37T
22	ECDC0047	SHIFT DRUM
23	ECDC0050	SHIFT ROD (2 REQ'D)
24	ECDC0048	SHIFT FORK, INPUT
25	ECDC0049	SHIFT FORK, OUTPUT (2 REQ'D)
26	HCDP1401	DOWEL, SOLID CENTERING (2 REQ'D)
27	ECKG0031	BEARING, PRIMARY SHAFT IGNITION SIDE
28A	ECMU0040	SHIM TRANSMISSION 0.030" (0.48mm) THICK
28B	ECMU0040T	SHIM TRANSMISSION 0.015" (0.4 mm) THICK
NOT SHOWN	ECMU0146	BUSHING, SWINGARM PIVOT ENGINE MOUNT (2 REQ'D)
32	ECMU0549	BEARING, NEEDLE, SHIFT DRUM LEFT SIDE

# Parts – Exhaust System

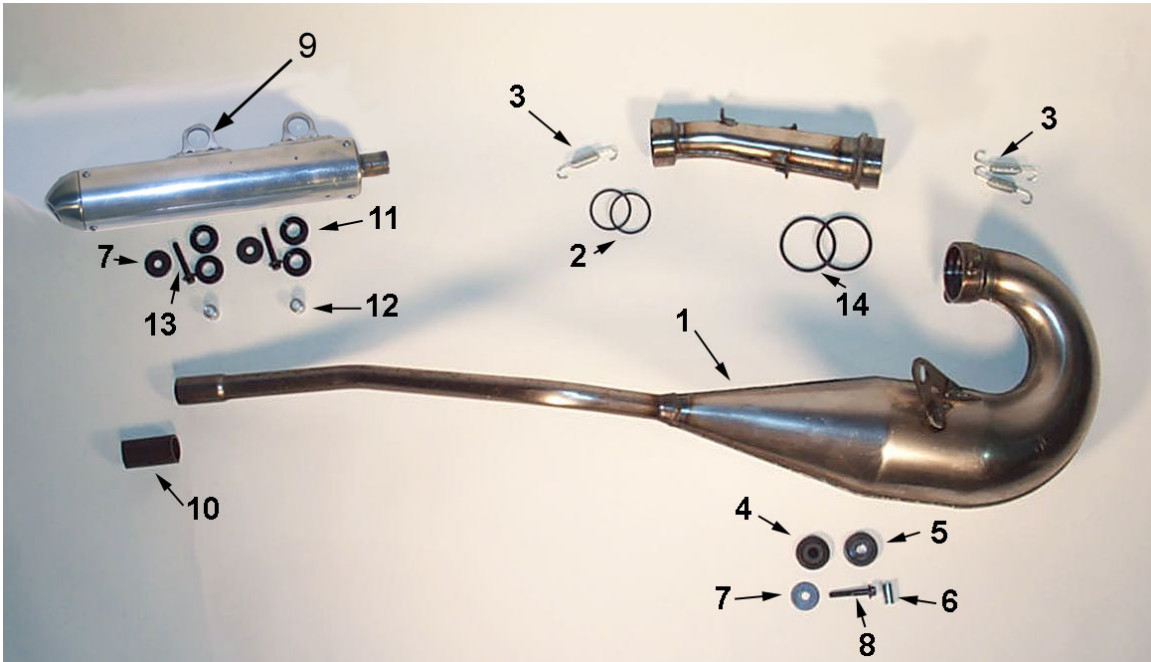

Figure 18

Exhaust System		
REF #	PART #	DESCRIPTION
1	XAEX2005	ECX70 EXHAUST PIPE
2	ZCMOTE11	HEADER PIPE O-RINGS (2 REQ'D)
3	XCMU0005	SPRING, EXHAUST – SHORT
NOT SHOWN	XCMU0030	COVER, EXHAUST SPRING
4*	MCMUGR02	PIPE GROMMET MALE (ONLY AVAILABLE IN MCMUGR02 GROMMET KIT)
5*	MCMUGR10	PIPE GROMMET FEMALE
6*	MCMUGR02	PIPE GROMMET SPACER (ONLY AVAILABLE IN MCMUGR02 GROMMET KIT)
7*	HCWF1478	PIPE GROMMET WASHER (2 REQ'D)
8*	HCBF0635	M6X35 FLANGE HEAD BOLT
	MCMUGR02	GROMMET KIT
NOT SHOWN	HCNL0601	6MM LOCK NUT – FOR FRONT PIPE MOUNT
9	XCMU0032	SILENCER
NOT SHOWN	XAEX0001	SILENCER – ‘STAR’ REINFORCED
NOT SHOWN	XCMU0026	SILENCER PACKING
NOT SHOWN	HCBB0408	M4 X 8 SILENCER SCREW
10	XCKG0009	PIPE / SILENCER SEAL
11	MCMUGR03	MOUNTING GROMMET (4 REQ'D TOTAL, 2 PER BOLT)
12	TCKG0001	SPACER (2 REQ'D)
13	HCBF0630	M6X30 FLANGE HEAD BOLT (2 REQ'D)
14	ZCEX0001	PIPE COUPLING O-RING (2 REQ'D)

\*Parts are included in MCMUGR02 grommet kit.



# Parts - Front A-Arms & Steering Upright

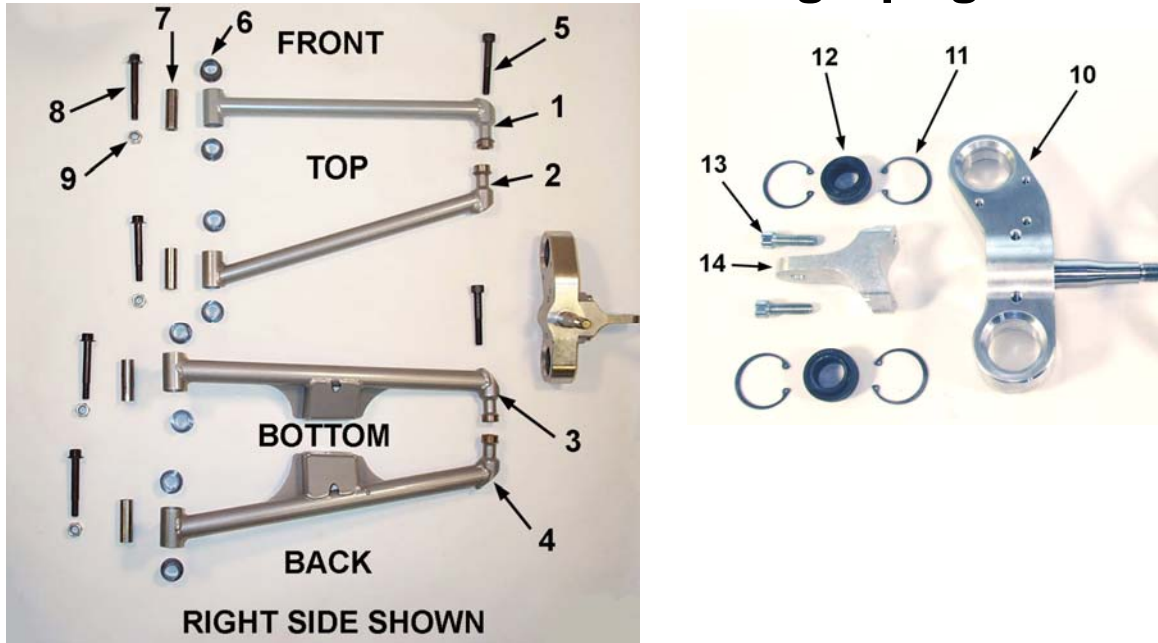

Figure 19

A-arms & steering upright		
REF #	PART #	DESCRIPTION
1	GAEX0001	A-ARM FRONT TOP (SAME PIECE FROM LEFT TO RIGHT)
2	GAEX0002	A-ARM BACK TOP (SAME PIECE FROM LEFT TO RIGHT)
3	GAEX0007	A-ARM FRONT BOTTOM RIGHT
	GAEX0006	A-ARM FRONT BOTOTM LEFT
4	GAEX0009	A-ARM BACK BOTTOM RIGHT
	GAEX0008	A-ARM BACK BOTTOM LEFT
5	HCBC1065	10MM X 65 SOCKET HEAD CAP SCREW (BLACK OXIDE)
6	MCEXBR05	BUSHING, A-ARM
7	GCEX0006	SPACER, A-ARM PIVOT TUBE
8	HCBF1070	10MM X 70 FLANGE HEAD BOLT
9	HCNL1001	10MM LOCKNUT
10	GAEX0003/4	UPRIGHT WITH SPINDLE, 03 Right, 04 Left
NOT SHOWN	GCEX0032	GREASE FITTING
11	MCEXCL01	SNAP RING, 1-3/8 INTERNAL
12	MCEXBR01	BEARING, SPHERICAL
13	HCBC0806	8MM X 30 SOCKET HEAD CAP SCREW (2 REQ'D)
14	GCEX0009	STEERING ARM

# Parts – Front Brakes

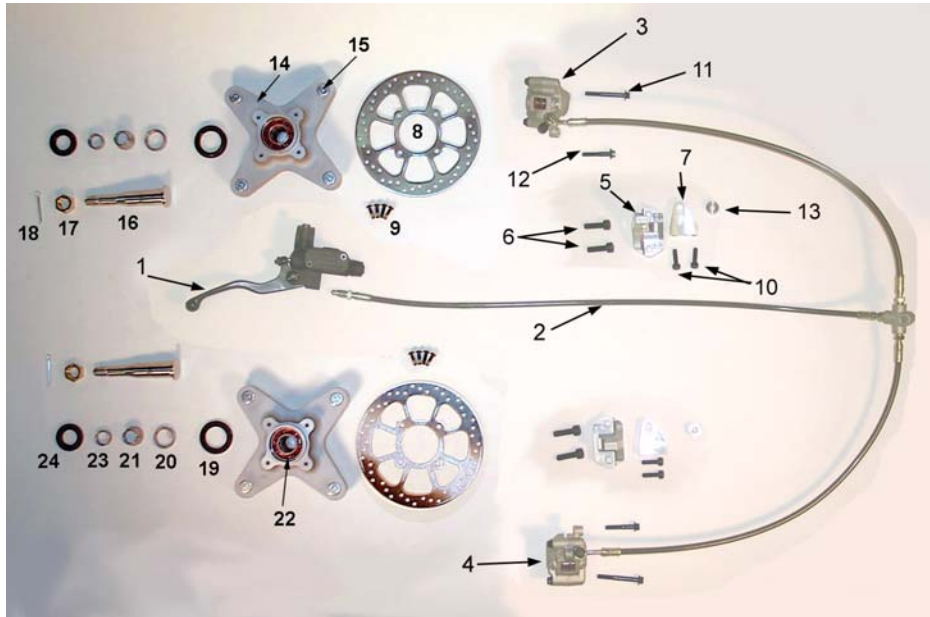

Figure 20

Front Brakes		
REF #	PART #	DESCRIPTION
	BAEX0004	BRAKE SYSTEM COMPLETE
	BCEX0024	BANJO BOLT
	BCEX0025	BRAKE PADS
	BCEX0029	CRUSH WASHER
1	BCDC0003	MASTER CYLINDER
2	BCEX0026	REPLACEMENT LINE
3	BCEX0028	CALIPER LEFT
4	BCEX0027	CALIPER RIGHT
5	BCEX0020	BRAKE ARM
6	HCBC0825	M8 X 25 SHCS
7	BCEX0021	BRAKE MOUNT
8	BCEX0019	BRAKE ROTOR
Not Shown	HCWF0504	BRAKE ROTOR SPACER (4 REQ'D PER ROTOR)
9	HCBB0516	ROTOR BOLT
10	HCBC0602	M6 X 20 SHCS
11	HCBF0640	M6 X 40 FLANGE HEAD BOLT
12	HCBF0635	M6 X 35 FLANGE HEAD BOLT
13	BCEX0022	BRAKE MOUNT SPACER
14	WCEX0001	FRONT HUB WITH WHEEL STUDS
16	GCEX0008	WHEEL SPINDLE (SAME L&R)
17	HCNS1400	M14 CASTLE NUT (SAME L&R)
18	HCCP0002	COTTER PIN (SAME L&R)
19	GCEX0022	INNER HUB SEAL (SAME L&R)
NOT SHOWN	ECKGBR01	INNER HUB BEARING
20	WCEX0301	INNER HUB BUSHING
21	WCEX0300	CENTER HUB SPACER
22	ECMU0001	OUTER HUB BEARING
23	WCEX0302	OUTER HUB BUSHING
24	GCEX0023	OUTER HUB SEAL
		BRAKE FLUID

## Parts – Front Shock

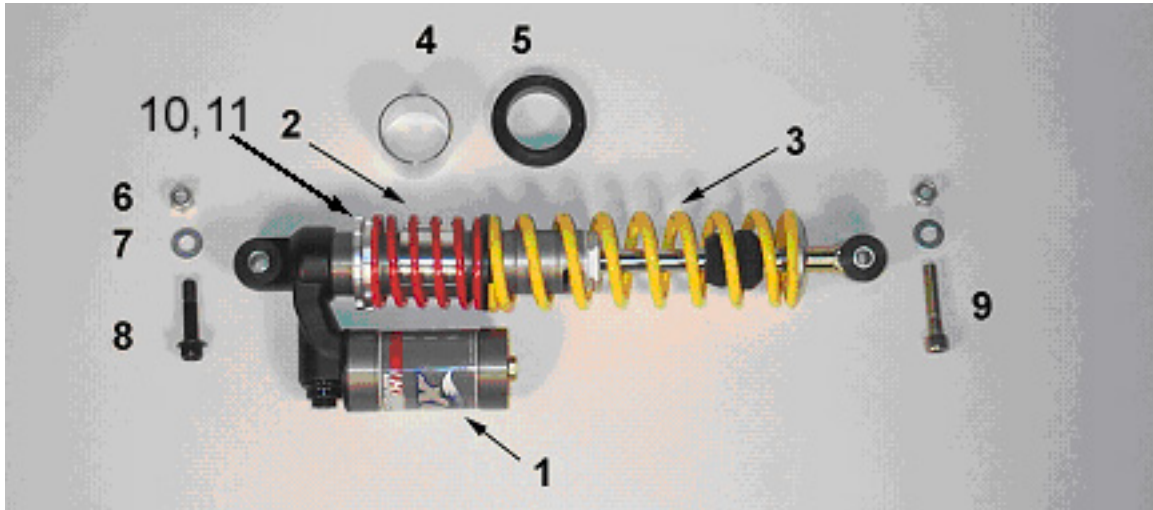

Figure 21

Front Shock		
REF #	PART #	DESCRIPTION
1	SAEX2005	SHOCK ECX70 – FRONT (2 REQ'D)
2	SCEX1080	SPRING, HELPER, 80 LB/IN (STANDARD)
		<i>See Optional Components section of this manual for other springs</i>
3	SCEX1145	SHOCK SPRING, STANDARD (RED, 145 LB/IN)
		<i>See Optional Components section of this manual for other springs</i>
4	SCSP0001	TRAVEL LIMITER (1.50")
	SCSP0002	TRAVEL LIMITER (1.25")
	SCSP0003	TRAVEL LIMITER (1.00")
5		TOP SPRING PERCH
6	HCNL1001	10MM LOCK NUT (2 REQ'D)
7	HCWF0010	10MM FLAT WASHER
8	HCBF1040	10MM X 44 SHOCK BOLT
9	HCBC1002	10MM X 50 SOCKET HEAD CAP SCREW
10	SCKGFX04	PRELOAD RING BOTTOM
11	SCKGFX05	PRELOAD RING TOP (LOCK RING)

## Parts – Miscellaneous

If you couldn't find it in one of the other pictures try the table below.

PART #	DESCRIPTION
WCEX0005	REAR WHEEL WITH TIRE
WCEX0004L	LEFT FRONT WHEEL WITH TIRE
WCEX0004R	RIGHT FRONT WHEEL WITH TIRE
FAEX2006	FRAME
FCEX0002	CHAIN SLIDER SPLIT BUSHING
HCBC1120	M10 X 120 (FRONT ENGINE MOUNT BOLT)
HCWF0010	10MM FLAT WASHER (2 REQ'D)
HCNL1001	10MM LOCK NUT
FCEX0038R	SPACER, FRONT ENGINE MOUNT RIGHT
FCEX0038L	SPACER, FRONT ENGINE MOUNT LEFT
FAE70001	ENGINE MOUNT – BOLT ON (2 REQ'D)
HCBC0816	8X16MM SOCKET HEAD CAP SCREW (4 REQ'D)

# Parts – Plastic Bodywork & Seat

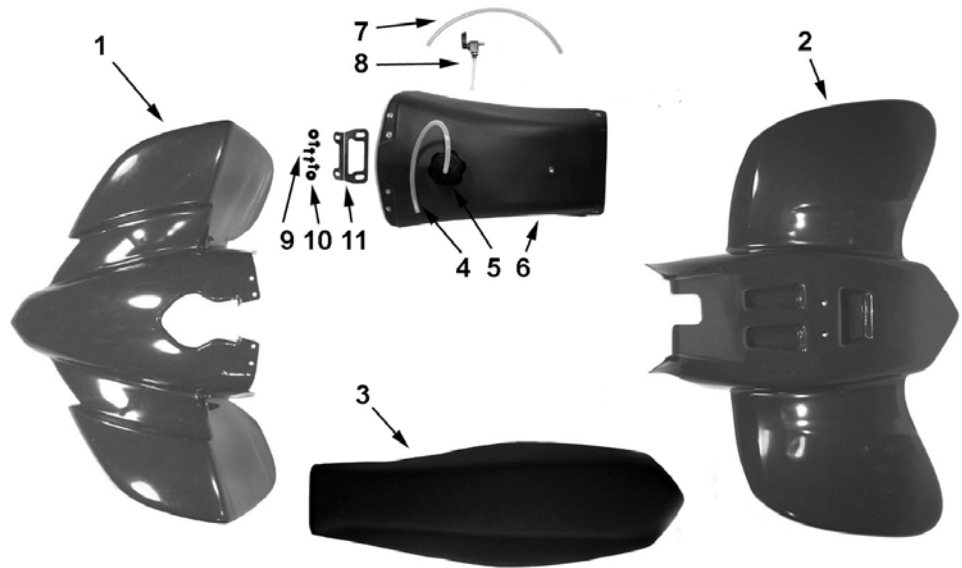

Figure 22

Plastic and Bodywork		
REF #	PART #	DESCRIPTION
1	TCEX0001Y	FRONT CLIP - YELLOW
NOT SHOWN	HCBB0616	M6 X 16 BUTTON HEAD (4 REQ'D AT BACK)
NOT SHOWN	HCWF0601	6 MM FLAT WASHER (4 REQ'D AT BACK)
NOT SHOWN	HCBB0625	M6 X 25 BUTTON HEAD (2 REQ'D AT FRONT)
NOT SHOWN	HCWF0601	6MM FLAT WASHER (2 REQ'D AT FRONT)
NOT SHOWN	MCMUGR10	GROMMET, (2 REQ'D AT FRONT)
NOT SHOWN	HCWF1478	WASHER, FENDER (2 REQ'D AT FRONT)
NOT SHOWN	HCNL0601	6MM LOCK NUT (2 REQ'D AT FRONT)
2	TCEX0002Y	REAR DECK - YELLOW
NOT SHOWN	HCBB0625	M6 X 25 BUTTON HEAD (2 REQ'D PLASTIC TO GRAB BAR)
NOT SHOWN	HCWF0601	6MM FLAT WASHER (2 REQ'D PLASTIC TO GRAB BAR)
NOT SHOWN	MCMUGR10	GROMMET, (2 REQ'D PLASTIC TO GRAB BAR)
NOT SHOWN	HCWF1478	WASHER, FENDER (2 REQ'D PLASTIC TO GRAB BAR)
NOT SHOWN	HCNL0601	6MM LOCK NUT (2 REQ'D PLASTIC TO GRAB BAR)
NOT SHOWN	HCBB0616	6MM BUTTON HEAD (2 REQ'D AT FRONT)
NOT SHOWN	HCWF0601	6MM FLAT WASHER (2 REQ'D AT FRONT)
3	TAEX0011	SEAT
NOT SHOWN	HCBB0635	M6 X 35 BUTTON HEAD (1 REQ'D SEAT TO PLASTIC)
NOT SHOWN	MCMUGR04	GROMMET (1 REQ'D SEAT TO PLASTIC)
NOT SHOWN	HCWF1478	WASHER, FENDER (1 REQ'D SEAT TO PLASTIC)
NOT SHOWN	HCNL0601	6MM LOCK NUT (1 REQ'D SEAT TO PLASTIC)
4	RCE50002	FUEL VENT HOSE
5	TCHA0002	FUEL CAP
6	TCEX0019	FUEL TANK (NO PETCOCK, CAP, OR BRACKET)
7	RCE50001	FUEL LINE
8	TCMU0000	FUEL PETCOCK ('06 LEVER)
9	HCBC0601	M6 X 16 SOC. HEAD BOLT (2 REQ'D)
10	MCMUGR04	GROMMET (2 REQ'D)
11	TCEX0110	FUEL TANK BRACKET
NOT SHOWN	TCHA0005	TANK MOUNT REAR
NOT SHOWN	HCFH0620	M6 X 20 FLAT HEAD
NOT SHOWN	HCBF0616	M6 X 16 FLANGE HEAD BOLTS (2 REQ'D)
NOT SHOWN	HCBF0620	M6 X 20 FLANGE HEAD BOLT (1REQ'D AT THE REAR)
NOT SHOWN	TCKG0001	SPACER, TANK MOUNT (1REQ'D AT THE REAR)
NOT SHOWN	TCEX2009	GRAPHICS

# Parts – Rear Brake

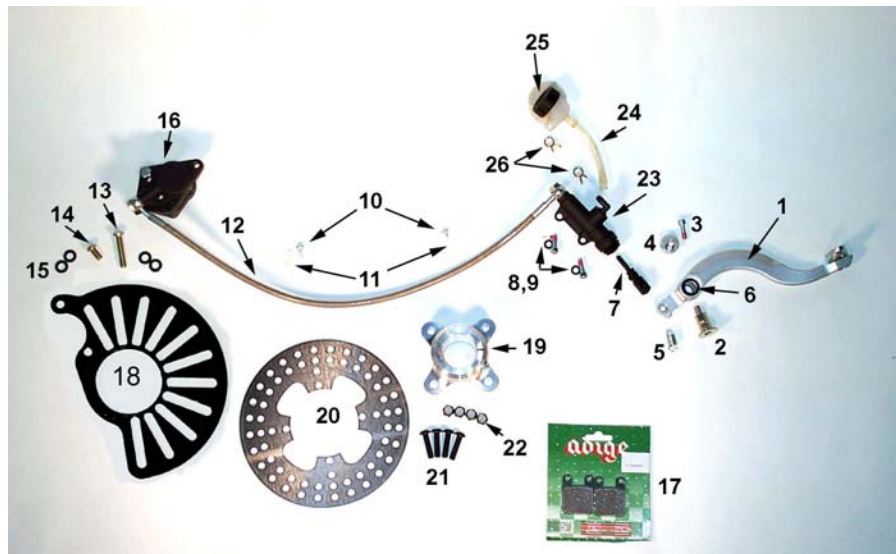

Figure 23

Rear Brake System		
REF #	PART #	DESCRIPTION
	BADC0001	BRAKE COMPLETE
1	BCEX0007	BRAKE PEDAL
2	BCDC0009	BRAKE PIVOT BOLT
3	HCBC0601	M6X16 SOC. HEAD BOLT
4	FCEX0018	BRAKE ADJUST ECCENTRIC
5	BCEX0012	BRAKE RETURN SPRING
6	BCMU0501	SEAL – BRAKE PEDAL (2 REQ'D)
7	BCDC0004	PUSH ROD, REAR BRAKE
8	HCBC0601	M6X16 SOC. HEAD BOLT (2 REQ'D)
9	HCWF0601	6MM FLAT WASHER (2 REQ'D)
10	HCPP0832	BRAKE HOSE CLAMP FASTENER (2 REQ'D)
11	HCCC0000	BRAKE HOSE CLAMP (2 REQ'D)
12	BCDC0151	REAR BRAKE HOSE
13	HCBC0850	M8X50 SOCKET HEAD CAP SCREW
14	HCBC0825	M8X25 SOCKET HEAD CAP SCREW
NOT SHOWN	BCEX0032	SPACER – CALIPER MOUNT
15	BCEX0014	CALIPER SPACER (2 REQ'D)
16	BCDC0002	CALIPER – REAR BRAKE
17	BCDC0007	BRAKE PAD KIT – ORGANIC
17	BCEX0013	BRAKE PAD KIT – SINTERED METAL
18	BAEX0006	REAR BRAKE CARRIER, FULL ADJUSTABLE
NOT SHOWN	GCEX0016	SPACER BRAKE HUB
NOT SHOWN	WCX0006	SNAP RING, BRAKE CARRIER RETAINER
19	GCEX0014	BRAKE/SPROCKET HUB
20	BCEX0004	BRAKE ROTOR REAR QUAD
NOT SHOWN	HCBC0625	6MM X 25 SOCKET HEAD CAP SCREW (2 REQ'D)
21	HCBB0830	8MM X 30 BUTTON HEAD (4 REQ'D)
22	HCNL0801	8MM LOCKNUT (4 REQ'D)
23	BCDC0005	MASTER CYLINDER - REAR
24	BCDC0012	BRAKE LINE – RESERVOIR TO MASTER CYLINDER
NOT SHOWN	HCBC0601	M6X16 SOC. HEAD BOLT
NOT SHOWN	WCMU0006	SPACER – RESERVOIR MOUNT
25	BCDC0006	BRAKE FLUID RESERVOIR
26	MCMUCL05	LINE CLAMP (2 REQ'D)
NOT SHOWN	BCDC0152	BANJO BOLT
NOT SHOWN	BCDC0153	CRUSH WASHER

## Parts – Rear Drive

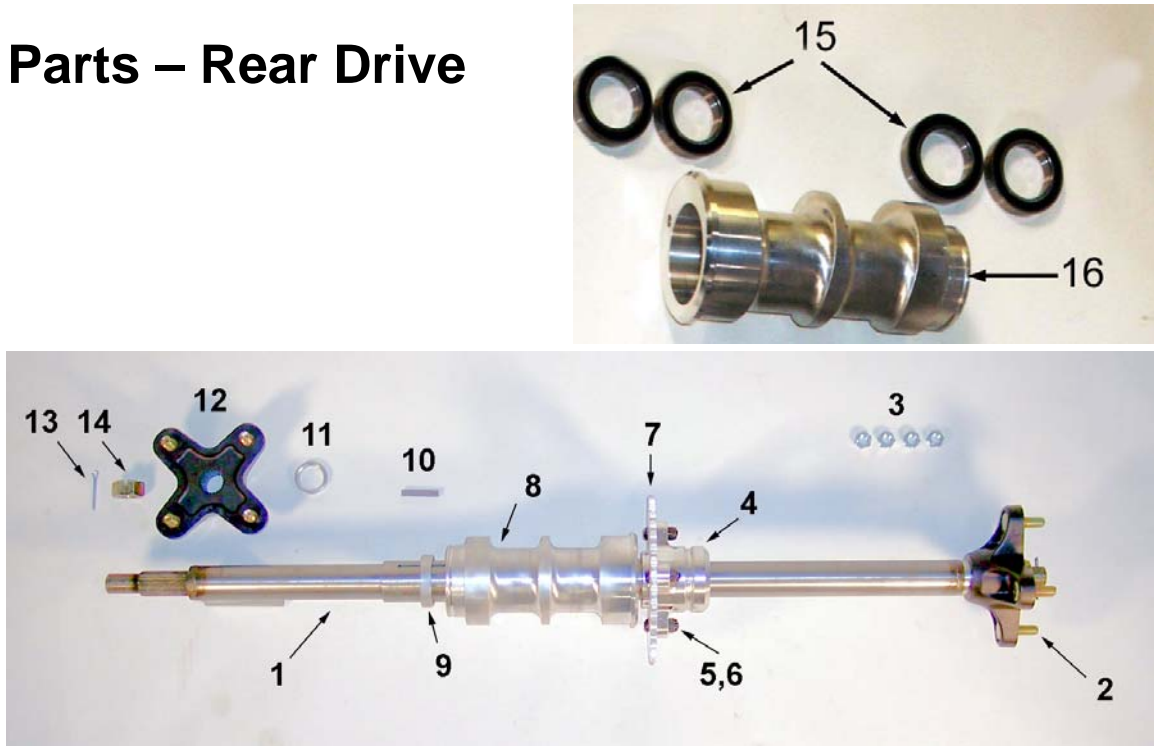

Figure 24

Rear Drive		
REF #	PART #	DESCRIPTION
1	GAEX0033	REAR AXLE -SOLID
2	WCEX0003	WHEEL LUG (8 REQ'D)
3	HCNS1001	LUG NUT (8 REQ'D)
NOT SHOWN	HCWF0010	LUG WASHER (8 REQ'D)
4	GCEX0014	BRAKE/SPROCKET HUB (2 REQ'D)
NOT SHOWN	HCBC0625	M6 X 25 HUB PINCH BOLT (2 PER HUB)
5	HCBH0808	M8 X 30 HEX HEAD BOLTS (4 REQ'D)
6	HCNL0801	M8 LOCK NUT (4 REQ'D)
7	PCDC00XX	SPROCKET (37T – 51T) – XX DENOTES # OF TEETH
9	GCEX0016	BRAKE HUB SPACER
10	HCKW0001	HUB KEY
11	GCEX0024	REAR WHEEL HUB SPACER (2 REQ'D)*
12	GCEX0011	REAR WHEEL HUB (2 REQ'S)
13	HCCP0002	COTTER PIN (2 REQ'D)
NOT SHOWN	PCMU0104	420 CHAIN – 104 LINK
14	HCNC0020	20 MM X 1.5 NUT CASTLE
15	MCEXBR03	BEARING, REAR AXLE (4 TOTAL, 2 PER SIDE)
16	GCEX0015	ECCENTRIC

- UP TO TWO HUB SPACERS CAN BE USED PER SIDE TO ADJUST TRACK WIDTH. USING THREE HUB SPACERS MAY CAUSE THE SPLINES TO STRIP.

## Parts – Rear Shock

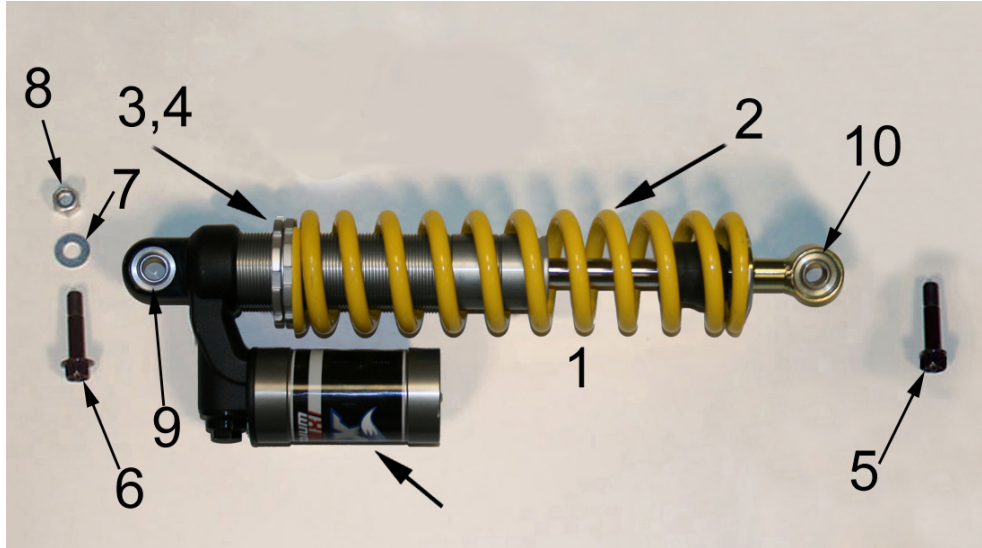

Figure 25

Rear Shock		
REF #	PART #	DESCRIPTION
1	SAE72009	SHOCK, REAR QUAD FOX
2	SCEX2375	SHOCK SPRING, STANDARD (WHITE, 375 LB/IN)
	SCEX2350	SHOCK SPRING, LIGHT (350 LB/IN)
	SCEX2400	SHOCK SPRING, HEAVY (400 LB/IN)
3	SCKGFX04	PRELOAD RING BOTTOM
4	SCKGFX05	PRELOAD RING TOP (LOCK RING)
5	HCBC1050	10MM X 50 SHCS
6	HCBF1040	10MM X 44 SHOCK BOLT
7	HCWF0010	10MM FLAT WASHER
8	HCNL1001	10MM LOCKNUT
9	SCKGFX01	TOP WIDTH REDUCER FOR BEARING STYLE END
9	ZCMU0114	TOP O-RING FOR BEARING STYLE END
10	SCEX0008	BOTTOM WIDTH REDUCER FOR BEARING STYLE END
10	ZCMUB208	BOTTOM O-RING FOR BEARING STYLE END



# Parts – Swingarm Assembly

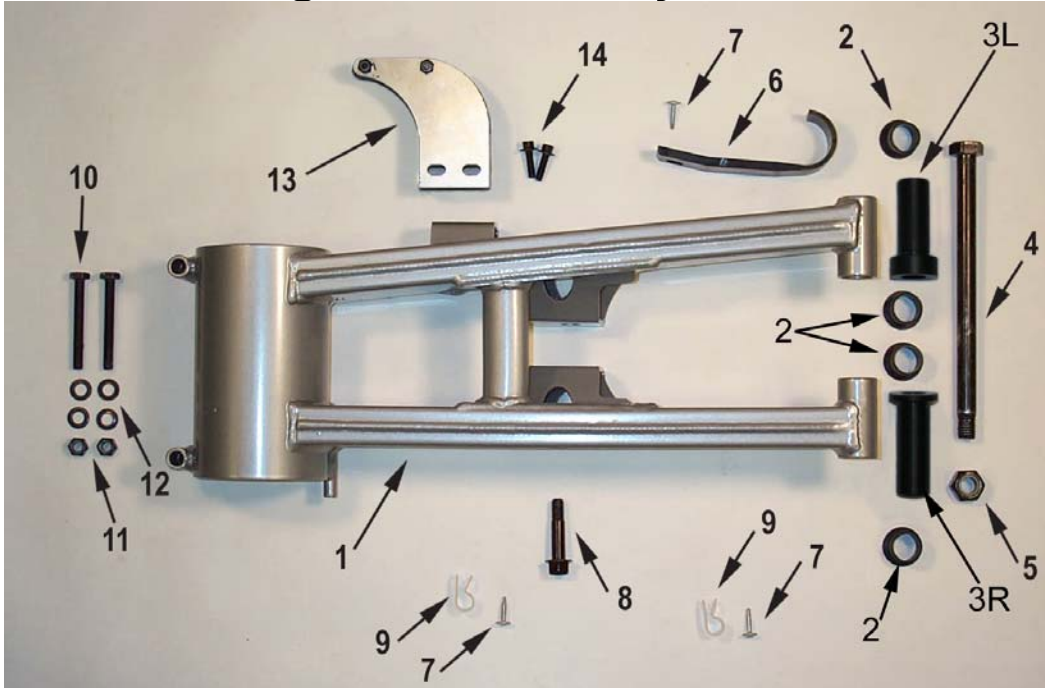

Figure 26

Swingarm		
REF #	PART #	DESCRIPTION
1	GAEX2009	SWINGARM
2	GCMU0030	BUSHING, SWINGARM (4 PER)
3R	GCE70005	SPACER, PIVOT TUBE (RIGHT SIDE / STEPPED SPACER WITH GROOVE)
3L	GCE70004	SPACER, PIVOT TUBE (LEFT SIDE / STEPPED SPACER WITHOUT GROOVE)
4	HCBH1421	SWINGARM PIVOT BOLT (M14 X 1 HEX HEAD)
5	HCNL1402	SWINGARM LOCK NUT (M14 X1)
6	GCEX0050	TOP SWINGARM GUARD – ECX70
7	HCPP0834	SELF TAPPING SCREW
8	HCBF1040	BOLT, SHOCK
9	HCCC0000	BRAKE HOSE CLAMP (2 REQ'D)
10	HCBH0810	ECCENTRIC PINCH BOLT (2 REQ'D)
11	HCNL0801	8MM LOCK NUT (2 REQ'D)
12	HCWF0801	8MM FLAT WASHER (4 REQ'D)
13	PAEX0001	CHAIN GUIDE ASSEMBLY COMPLETE W/ ALUMINUM PLATE
14	HCBF0620	6MM X 20 FLANGE HEAD BOLT (2 REQ'D)

# Parts – Tie Rod Assembly

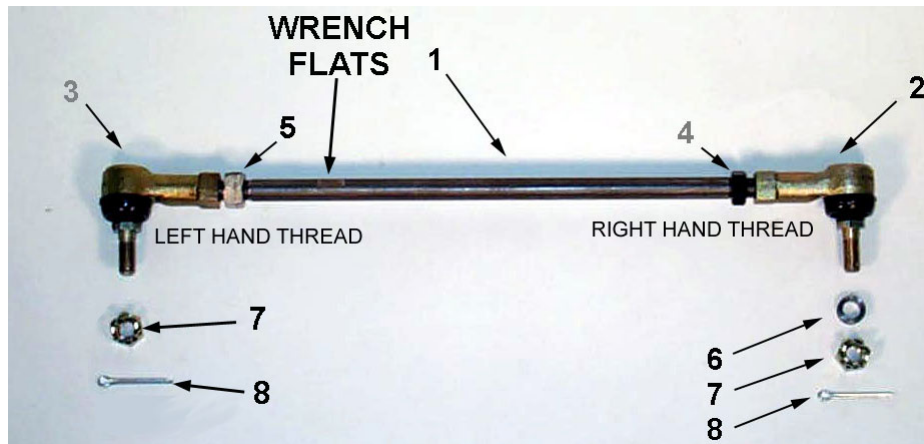

Figure 27

Tie Rod Assembly		
REF #	PART #	DESCRIPTION
1	FAEX0002	TIE ROD
2	MCEXBR02R	RH TIE ROD END
3	MCEXBR02L	LH TIE ROD END
4	HCNJ120L	LH JAM NUT
5	HCNJ120R	RH JAM NUT
6	GCEX0002	SPACER, BALL JOINT
7	HCNC0010	10MM CASTLE NUT (2 REQ'D)
8	HCCP0003	COTTERPIN 3/32" X 3/4" (2 REQ'D)

# Engine Parts / Service

Trained technicians with precision gauging and proper assembly fixtures carefully assemble all Cobra engines to specific tolerances. If you feel you have the skills, and the appropriate tools, to perform the following service tasks please follow the instructions closely. The part numbers are listed throughout to help you when ordering parts from your local Cobra dealer.

If you don't feel comfortable with the service work, log on to [www.cobramotorcycle.com](http://www.cobramotorcycle.com) to find a Cobra dealer or Call 517 437 9100.

## Engine Service

One method for determining whether the top end of your engine needs rebuilt is to perform a WOT (Wide Open Throttle) kicking compression test. Before performing the procedure please read the caution notes below.

### CAUTION:

- There appears to be a wide range of variability in reading compression gauges across the country.
- The head volume of this Cobra Motorcycle is very small and so requires many kicks ~20 before you establish the most accurate reading possible.
- Because of the geometry of the spark plug used in this Cobra Motorcycle, the adapter used with your compression tester must have a similar volume protruding into the combustion chamber to establish an accurate value.
- Length of hose on the compression tester will affect the reading. The shorter the hose length the more accurate your reading will be.

Because of these difficulties in measuring an *absolute* compression value, a useful *relative* value can be achieved by testing your bike's compression with your own particular gauge after a new top end or when the bike is new so that you know what your particular gauge reads on a 'fresh' engine. When it has dropped to 90% of its original value the engine will be down on power and would benefit from a rebuild. When it's dropped to 80% it really needs rebuilt! Using the table below will help you determine monitor the condition of your top end.

	Engine is Fresh Measured Value	Engine Down on Power Measured Value * 0.9	Engine NEEDS Rebuilt Measured Value * 0.8
Example	110 psi	110 psi * 0.9 = 99 psi	110 psi * 0.8 = 88 psi
Your Values			

## Procedure for Compression Testing

1. Shut off the fuel petcock.
2. Install the compression gauge into the spark plug hole.
3. Hold the throttle to wide open, and kick repeatedly (approximately 20 times) or until the gauge reading does not increase in value with each kick.

## Base Gasket Selection

### Tools required

- 17mm wrench
- 1mm flexible solder material
- measurement calipers

When rebuilding the 'top end' of your Cobra motorcycle, care must be taken to ensure the proper squish clearance. Squish clearance is defined as the minimum distance between cylinder head and piston at TDC, and there are negative effects of either having too much or too little clearance. Since parts like the crank, connecting rod, cylinder head, piston, and crankcases all have varying tolerances, Cobra offers several different base gasket thickness' to ensure that you can always set the squish clearance of your engine to factory specifications.

For base gasket replacement use the code (see figure 21 for location) along with the table on the following page reorder the correct thickness gasket.

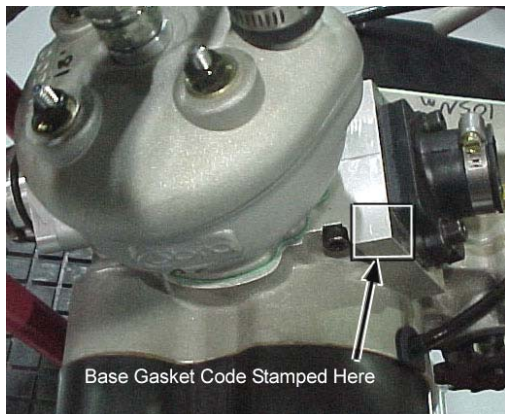

Figure 21

Code	Supplied Base Gasket Thickness		Cobra #
	#	mm	inch
2	0.2	0.008	ZCMU0702
	0.25	0.010	ZCMU0011
3	0.3	0.012	ZCMU0703
4	0.4	0.015	ZCKG0501
5	0.5	0.020	ZCMU0705
6	0.6	0.024	ZCMU0706
7	0.7	0.028	ZCMU0707
8	0.8	0.031	ZCMU0708
9	0.9	0.035	ZCMU0015
1	1.0	0.039	ZCMU0016

**NOTE**

Tolerances will affect the actual gasket thicknesses.

If during the course of the maintenance more parts than the base gasket are changed, the squish clearance should be measured, and possibly a different base gasket will be required.

The easiest way to measure squish clearance is with 1mm to 1.5mm thick flexible solder wire (available through most popular electronic stores). The process is as follows:

- Assemble the top end of the engine with either; 1) the crankcase stamp recommended base gasket or, 2) if assembling with a new set of cases assemble with a 0.4mm (0.015”) base gasket, and torque the head nuts to the proper torque specifications leaving off the spark plug and ignition cover (piston rings can be left off to ease assembly).
- Carefully insert the solder wire through the spark plug hole, into the cylinder far enough such that the tip of the wire touches the left or right side cylinder wall (not the front or back as the piston will rock more and give incorrect measurement).
- Hold the wire at this position and rotate the crankshaft, by the flywheel nut (or kick lever) three revolutions to ‘smush’ the solder wire.

**CAUTION:**

If you rotate the flywheel nut in a counterclockwise direction there is a risk of loosening the nut.

- Pull out the wire and measure the solder thickness at the thinnest location near its tip accurately with the thin tips of calipers.
- Adjust base gasket thickness as necessary to get the desired value.

Upon completion, your final assembly squish clearance should agree with the chart below

## Measured Squish Clearance (minimum)

(These numbers only apply when measured as described above)

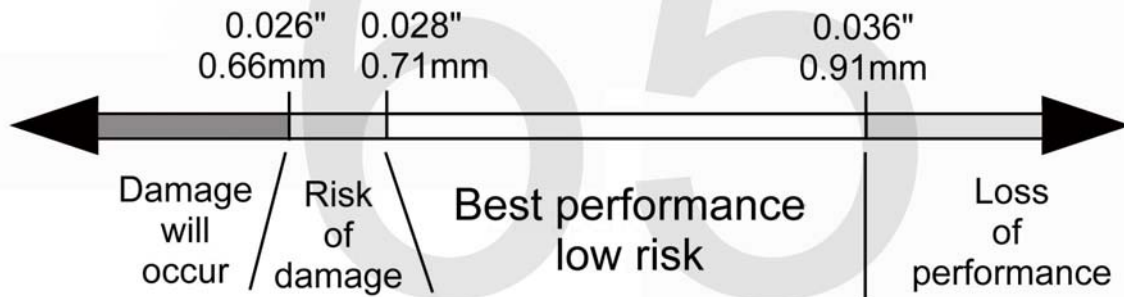

## Fuel & Air System

### Reeds

#### CAUTION:

- The reeds must lay flat on the reed cage.
- If the reed tips aren't lying flat, replace them immediately.
- The reeds must have a tight seal on the reed cage.
- If the reed is damaged in any way, replace it. This means cracks, chips, and ruptures. Anything abnormal, replace the reeds.

Take the reed cage out and hold it up to the light and look in through the cage. If you see light between the reed pedals and the frame, then replace the reeds. If you do not see light, then the reeds should be ok. (See figure 28)

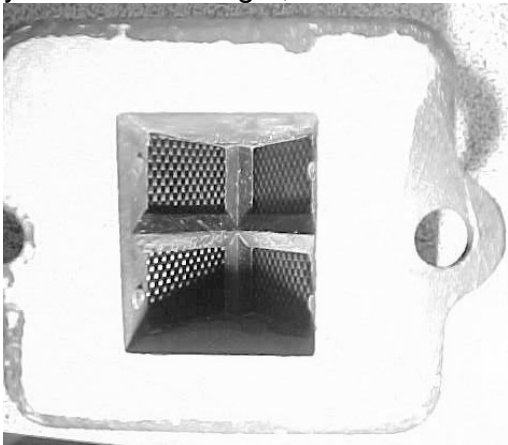

Figure 28, The presence of light indicates that the reeds should be replaced, or possibly turned over.

## Carburetor Cleaning

### **WARNING**

Clean the carburetor in a well-ventilated area, and take care that there is no spark or flame anywhere near the working area; this includes any appliance with a pilot light. Because of the danger of highly flammable liquids, do not use gasoline or low flash-point solvent to clean the carburetor.

1. Make sure the fuel is shut off.
2. Remove the carburetor.
3. Drain the fuel in the carburetor.
4. Disassemble the carburetor.

### **CAUTION:**

Do *not* use compressed air on an assembled carburetor. Or the pressure may deform the float. Do not use a strong carburetor cleaning solution, which could attack the parts of the carburetor; instead, use a mild high cleaning solution safe for plastic parts.

5. Immerse all the metal parts in a carburetor cleaning solution.
6. Rinse the parts in water.
7. After the parts are cleaned, dry them with compressed air.
8. Blow out the fuel passages with compressed air.
9. Assemble the carburetor
10. Install the carburetor onto the motorcycle.

## **Exhaust**

The pipe is a crucial element to a two-stroke engine. Any kinks, dents, or damage done to the pipe will result in a performance loss.

### **NOTE:**

Be sure to take the pipe off, and remove any carbon that may be built up. Carbon build up is created from exhaust. Exhaust has oils in it, and the oils cling to the walls of the inside of the pipe. Over a long period of time, the diameter of the pipe will decrease, due to carbon build up. So it is essential to clear the residue.

### **CAUTION:**

For optimum performance it is important to repack the silencer. Signs of your silencer needing to be repacked are:

- The bike is louder than normal.
- A loss of power.

# Tuning

## Carburetor

### Jetting Decisions

---

Although your Cobra is sent from the factory with the carburetor jetted for optimal performance, you may find it necessary to adjustment your particular jetting due to current weather conditions, altitude, fuel variations, and/or engine modifications.

**CAUTION:**

Proper jetting is very important for engine performance and engine life. Symptoms of improper jetting are listed below.

- Symptoms of incorrect oil or oil / fuel ratio
  - Poor acceleration
  - Misfire at low engine speeds
  - Excessive smoke
  - Spark plug fouling
  - Excessive black oil dripping from exhaust system
- Symptoms of too rich a fuel mixture
  - Poor acceleration
  - Engine will not 'rev' out, blubbers on top
  - Misfire at low engine speeds
  - Excessive smoke
  - Spark plug fouling
  - Wet, black, or overly dark spark plug (when removed for inspection)
- Symptoms of too lean a fuel mixture
  - Pinging or rattling
  - Erratic acceleration
  - Same actions as running out of fuel
  - High engine temperature
  - White spark plug (when removed for inspection)

**NOTE:**

When inspecting the spark plug to evaluate jetting, a properly jetted machine will produce a spark plug that is dry and light tan in color.

<b>Environmental and altitude related mixture adjustments</b>		
<b>Condition</b>	<b>Mixture will be</b>	<b>Required adjustment</b>
Cold air	Leaner	Richer
Warm air	Richer	Leaner
Dry air	Leaner	Richer



Very humid air	Richer	Leaner
Low altitude	Standard	None
High altitude	Richer	Leaner
Low barometric pressure	Richer	Leaner
High barometric pressure	Leaner	Richer

**NOTE:**

- Before making any carburetor jetting changes verify that:
  - You are using the proper fuel and oil
  - The fuel is fresh and uncontaminated
  - The oil and fuel have been mixed in the proper ratio
  - The carburetor is clean (no plugged jets)
  - The air filter is properly clean and oiled
  - The float height is within proper specification (proper measuring technique is described later in this section)

**NOTE:**

Perform all jetting changes on a motorcycle that has been warmed up to proper operating temperature.

The carburetor on your Cobra motorcycle is quite adjustable. Figure 8 shows its range of adjustment and in particular what adjustable component affects what range of operation (specifically throttle position).

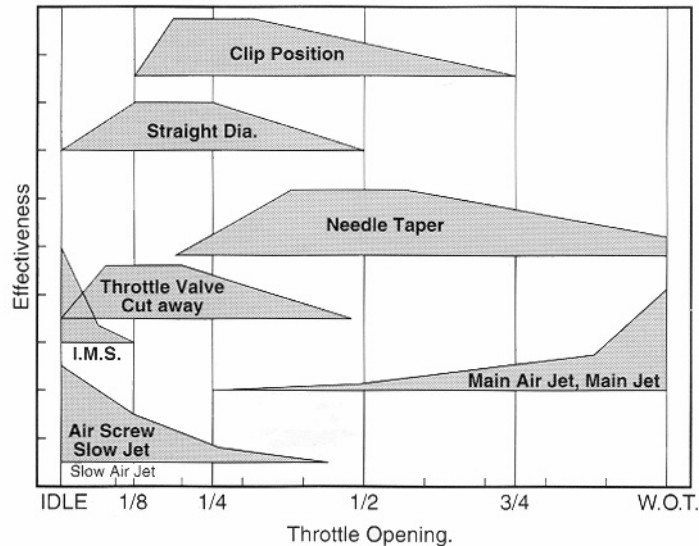

**Figure 29**

**AIR SCREW ADJUSTMENT:**

**Adjust for maximum idle speed**

The air adjustment screw is located on the left side of the carburetor. It is the smaller of the two adjustment screws and requires the use of a small flat blade screw driver for adjustment. After adjusting for maximum idle speed, use the idle screw to adjust the desired idle speed.

**NOTE:**

If the air screw requires more than 3 turns out, replace the pilot jet for one that is one size leaner (smaller number) then readjust the air screw.

**IDLE ADJUSTMENT:****Adjust for desired idle speed**

The idle speed screw is located on the left side of the carburetor. It is the larger of the two screws on the side of the carburetor and is unique with its knurled head for easy fingertip adjustment. To raise the idle, turn the screw in, clockwise, (in 1/4 turn increments) and rev the engine after each adjustment. To lower the idle, turn the screw counter-clockwise.

**TOP END JETTING:****Adjust for clean full throttle acceleration**

Jet your top end (main jet) based on the acceleration of your Cobra Motorcycle on the longest straight at the track. Observe any of the lean or rich symptoms (spark plug appearance and bike performance) listed above and change your jetting accordingly.

**PART THROTTLE****Adjust for desired acceleration**

Using an area of the track that allows the rider to operate and mid throttle and transition (accelerate, or 'roll on') from closed, or mostly closed throttle, to a larger throttle opening. Observe the rich and lean symptoms listed above. Adjust the jet needle position by moving the clip from its current position (move the clip higher on the needle to make the bike run leaner, or move the clip lower on the needle to make the bike run richer) to one higher or lower.

# Troubleshooting

## **1) Engine not behaving properly**

- a) Carburetor top is installed backwards (happens a lot)
- b) The carburetor slide indexing pin is missing

## **2) Engine is down on power**

- a) Clutch engagement is not set properly
- b) Jetting is incorrect
- c) Silencer needs repacked
- d) Exhaust pipe
  - i) Has excess carbon buildup
  - ii) Has large dent in it
- e) Compression is low
  - i) Piston
  - ii) Rings
- f) Reeds are damaged
- g) Ignition timing is incorrect

## **3) Engine is excessively loud**

- a) Silencer needs repacking

## **4) Engine 'blubbers' at high RPMs**

- a) Jetting too rich

## **5) Engine won't start**

- a) Fuel
  - i) None in tank
  - ii) Is sour or bad
- b) Carburetor is dirty
- c) Ignition
  - i) Spark plug fouled
  - ii) Spark plug cap off
  - iii) Engine Shut-off 'kill' switch is shorted
  - iv) Bad electrical ground
  - v) Stator winding damaged
- d) Exhaust is plugged

## **6) Engine won't idle**

- a) Idle knob needs adjusted
- b) Carburetor jets are dirty

# Index

A-arms .....	31	Parts .....	30
Air Filter .....	16	Fenders .....	35
Maintenance.....	14	Frame Parts .....	34
Axle.....	37	Front Brake .....	32
Bars and Controls .....	17	Fuel	
Base Gasket Selection.....	42	Petcock.....	9
Break-In .....	8	Fuel System	
Bumper .....	18	Parts list.....	44
Carburetion		Service.....	44
Specifications .....	3	Gas Tank.....	35
Carburetor.....	19	General Tips.....	10
Chain		Grab Bar.....	18
Adjustment .....	13	Hardware	
Chassis		Frame .....	34
Specification .....	3	Plastic.....	35
Torque.....	6	Jetting	
Clutch.....	23	Stock.....	3
Clutch Cover .....	24	Troubleshooting .....	46
Clutch Lubricant		Kick Mechanism .....	26
Replacing .....	12	Lubrication	
Compression test.....	42	Recommended .....	3
Cylinder.....	28	Maintenance	
Eccentric .....	37	Schedule.....	11
Electrical		Tips.....	11
Parts.....	22	Nerf Bars .....	18
Engine		Oil	
Parts List .....	41	Recommended .....	3
Specifications .....	3	Optional Components.....	6
Torque.....	5	Parts	
Engine Mount Front .....	34	Inlet.....	44
Exhaust.....	45	Reeds .....	44

Petcock .....	9	Steering Stem .....	17
Piston .....	28	Steering Upright .....	31
Plastic .....	35	Swingarm Parts .....	39
Radiator .....	21	Throttle .....	16
Rear Brake		Tie Rod.....	40
Parts .....	36	Tips .....	10
Rear Drive.....	37	Toe In Adjustment .....	15
Rear Shock		Top End	
Parts .....	38	Parts .....	28
Reeds .....	44	Torque	
Parts .....	16	Chassis.....	6
Rings.....	28	Engine .....	5
Seat .....	35	Transmission.....	29
shift drum.....	29	Specifications .....	3
shift forks .....	29	Transmission Lubricant	
Shift Mechanism .....	27	Replacing.....	12
Shock.....	33	Troubleshooting	
Spark Plug		General.....	49
Recommended .....	3	Jetting.....	46
Specifications.....	3	VIN reading .....	10
Torque Values.....	5	WARNING .....	0
Spherical Steering Bearing .....	15	Water Pump Cover.....	24
Starting .....	9	Wheels .....	34