

2004 CM50



Owners / Service / Parts



“CHAMPIONS START HERE”

For **parts orders** contact your local dealer

To locate your closest Cobra dealer
log on to

www.cobramotorcycle.com

or call

(517) 437 9100

If you need **technical assistance**
contact your local dealer or call
the Cobra Technical Support Hotline at
(517) 437-9100



Cobra Motorcycle MFG., Inc.
240 Uran Road
Hillsdale, MI 49242

DISCLAIMER OF WARRANTY

This motorcycle is sold "as is" with all faults, obvious or not. There are no warranties expressed or implied, including any warranty of merchantability and warranty of fitness for any particular purpose.

"WARNING"

THE COBRA CM50 IS A COMPETITION MODEL ONLY AND IS NOT MANUFACTURED FOR, NOR SHOULD IT BE USED ON PUBLIC STREETS, ROADS OR HIGHWAYS.

THE USE OF THIS BIKE SHOULD BE LIMITED TO PARTICIPATION IN SANCTIONED COMPETITION EVENTS UPON A CLOSED COURSE BY A SUFFICIENTLY SKILLED RIDER AND SHOULD NOT BE USED FOR GENERAL OFF-ROAD RECREATIONAL RIDING.

IMPROPER USE OF THIS MOTORCYCLE CAN CAUSE INJURY OR DEATH.

THIS BIKE IS INTENDED FOR EXPERIENCED RACERS ONLY AND NOT FOR BEGINNERS.

IT IS YOUR RESPONSIBILITY AS THE OWNER OF THIS COBRA MOTORCYCLE OR AS THE PARENT, OR LEGAL GUARDIAN OF THE OPERATOR, TO KEEP THIS COBRA MOTORCYCLE IN PROPER OPERATING CONDITION.

THIS BIKE WAS DESIGNED FOR RIDERS THAT WEIGH LESS THAN 80 LBS WITH FULL RIDING GEAR AND SHOULD NOT BE OPERATED BY RIDERS THAT WEIGH MORE THAT.

BE SURE THAT THE RIDER ALWAYS WEARS ADEQUATE SAFETY GEAR EVERYTIME HE OR SHE RIDES THEIR COBRA MOTORCYCLE.

IMPORTANT SAFETY NOTICE

WARNING

Failure to follow WARNING instructions could result in severe injury or death to the machine operator, a bystander, or a person inspecting or repairing the machine.

CAUTION:

A CAUTION indicates special precautions that must be taken to avoid damage to the machine.

NOTE:

A NOTE provides key information to make procedures easier or clearer.

MCCM2004.5

Table Of Contents

Specifications - General.....	5
Specifications - Torque Values	7
Optional Components	8
Break-In Procedure.....	9
Starting Procedure	10
General Tips	11
Maintenance	12
Schedule & Tips	12
M1: Replacing Transmission / Clutch Lubricant	13
M2: Chain adjustment	14
M3: Front brake adjustment	15
M4: Rear brake adjustment	15
M5: Air Filter Cleaning.....	16
M6: Fork Oil Replacement.....	17
Parts	19
Parts – Airbox and Inlet System	19
Parts – Bars and Controls	20
Parts - Carburetor.....	21
Parts – Coolant System.....	22
Parts – Electrical System	23
Parts – Engine – Bottom End and Transmission	24
Parts – Engine – Clutch and Kick Starter.....	25
Parts – Engine – Ignition and Water Pump.....	26
Parts – Engine – Top End.....	27
Parts – Exhaust System	28
Parts – Forks & Triple Clamps.....	29
Parts – Forks – Leg Assembly	30
Parts – Frame – Mounting Hardware I	31
Parts – Frame – Mounting Hardware II.....	32
Parts - Frame – Mounting Hardware III.....	33
Parts – Front Brakes	34

Parts – Front Wheel	35
Parts – Plastic Bodywork & Seat	36
Parts – Rear Brake	37
Parts – Rear Wheel	38
Parts – Shock	39
Parts – Swingarm Assembly	40
Service	41
Engine Service	41
Engine Removal	42
Complete Engine Disassembly Procedure	43
Top End Disassembly Procedure	43
Splitting the Cases	44
Engine assembly	45
Clutch	51
Ignition	57
Cooling System	59
Fuel & Air System	63
Exhaust	66
Wheels & Tires	67
Suspension	69
Troubleshooting	70
Index	71

Specifications - General

Items	CM 50
Dimensions	
Wheelbase	35.75" (908mm)
Wheel size	10" (254mm)
Seat height	23.9" (607 mm) Stock #TCHJ0001 22" (559 mm) Optional # TCHO0001
Engine	
Type	2-stroke, single cylinder, reed valve
Cooling system	Liquid-cooled
Displacement	49.8 cc
Bore and stroke	39 mm x 41.7 mm
Ignition system	Electronic
Spark plug	Champion 8339-1, 8332-1 hotter, 8904-1 colder
Gap	0.023" – 0.025" (0.58 – 0.64 mm)
Ignition timing	0.050" (1.3 mm) Before To Dead Center (BTDC)
Fuel type	High octane pump gasoline RACE FUELS ARE NOT RECOMMENDED
Oil type	<i>Cobra Venom 2-cycle Race Oil</i>
Fuel / oil mix ratios	Between 32:1 and 40:1 (after engine Break-In)
Carburetion	14 mm Dell'Orto
Main Jet	92
Slow (Pilot) jet	55
Float Height	16mm ± 0.5mm (0.63" ± 0.020")
Transmission	
Speed	Single
Clutch	Cobra 3 shoe
Final drive ratio	13/37 T
Chain	88 links 420
Transmission / clutch oil type	<i>Cobra Venom 3 Shoe Clutch Milk</i> , or Dexron III
Quantity	235 ml (8.0oz)

Chassis		
Front tire		2.50 - 10
	Pressure	15 psi minimum
Rear tire		2.75 - 10
	Pressure	15 psi min. (20 psi for hard pack or rocky conditions)
Front fork		Marzocchi 32mm
	Fork oil type	SAE 20 weight
	Fork oil amount	200 ml (6.8 oz) oil change, 220 ml (7.4 oz) rebuild
	Collapsed fork oil height	70 mm (2.75") spring in, no spacer

Specifications - Torque Values

Fastener	Torque Value			Size &
	ft-lb	in-lb	Nm	Remarks
Cylinder head nuts	8.8	105	12	1/4"
Crankcase bolts	8.8	105	12	6 x 1.0
Spark plug	(SP)	(SP)	(SP)	14 x 1.25
Stator bolts	2.1	25	2.8	#8
Stator cover bolts	1.7	20	2.3	#8
Clutch cover bolts	5.8	70	7.9	6 mm
Clutch	40	480	54	10 x 1.25***
Engine mount bolts	22	265	30	8 mm
Swingarm Pivot	21	250	28	14 mm
Intake manifold bolts	4.6	55	6.2	6 mm
Ignition rotor nut	40	480	54	10 x 1.25 mm**
Rear Sprocket Bolts	18	216	24	7 mm
Rear shock mounts	40	480	54	10 x 1.5
Rear Axle Bolt	25	300	34	12 mm

** Use green (wicking / bearing retainer) thread locker, with primer, on the flywheel / crankshaft taper but none on the threads.

*** Use green (wicking / bearing retainer) thread locker, with primer, on the crankshaft / clutch taper but use red (high strength) thread locker, with primer, on the nut.

(SP) To apply the proper torque to the spark plug when inserting, one must first screw the spark plug in until the metal gasket ring causes resistance and then turn another 1/8 to 1/4 turn.

Optional Components

Call your dealer, or the factory, for details

- Carburetor jets
- Sprockets
 - Front
 - Rear
- Suspension Springs

Weight of Rider (lb)	Fork Spring	Shock Spring
Less than 38 (light)	KCMZ0012A	SCMUOH04 (275 lb/in) red
38 – 45 (std)	KCMZ0012	SCMUOH05 (285 lb/in) yellow
46 to 55 (stiff)	KCMZ0012B	SCMU0H06 (295 lb/in) white

Break-In Procedure

Your Cobra CM50 is a close-tolerance high performance machine and break-in time is very important for maximum life and performance. The CM50 can be ridden hard after the first ½ hour break-in time but it is recommended that no adjustments are made to the carburetion or suspension until the full 8 hours of bike break-in has elapsed. Also, after the engine, transmission, and drive train have been broken-in for the full 8 hours, the bike will be faster!

Use a fuel / oil mixture of 32:1 for the full 8 hour break-in period. Be sure to use high octane pump gas with Cobra's specially formulated *Cobra Venom 2-cycle Race Oil*. (Part # MCMUOL02)

CAUTION:

Failure to use proper fuel, oil, or fuel/oil mixture may result in premature engine wear or damage to the machine.

Adhering to the following break-in schedule will result in long lasting high performance machine.

- First ½ hour of operation
 - Follow the starting procedure listed in this manual.
 - Avoid prolonged operation at Wide Open Throttle.
- After 1 hour of operation
 - Check for loose bolts and nuts on the bike and retighten as necessary (proper torque values are listed under Specifications).
 - Clean the carburetor bowl.
 - Change the transmission / clutch lubricant.
- After 8 hours of operation
 - Change the fork oil.
 - Have a Certified Cobra Mechanic change the shock oil.
- Your bike is now ready for the highest level of competition!

NOTE:

During break-in the bike will likely lose some engine coolant through the radiator overflow hose. Losing up to 4 oz (120 ml, ½ cup) is normal. Proper coolant level will cover the top of the radiator cores. Removing the radiator cap and looking inside is the only way to check the coolant level.

WARNING

Never open the radiator cap of a machine that has a hot or warm engine or one that has recently been ridden. Burning and scalding could occur.

CAUTION:

It is important that the radiator cap is installed correctly and completely otherwise engine damage could occur.

Starting Procedure

Before starting the machine inspect the following:

- Check for proper tire pressure in both tires.
- Observe the chain tension and adjust if necessary.
- Observe the coolant level and fill if necessary.
- Verify that the chain rollers do not have improper wear.
- Verify that the handlebars are tight.
- Check the throttle for smooth operation and sound closing.
- Check for loose bolts and nuts, and re-torque as necessary.
- Verify that the air filter is clean and properly saturated with oil.
- Insure that the fuel tank contains an adequate volume of fuel / oil mixture to complete the distance required. (High octane pump gas with Cobra's specially formulated *Cobra Venom 2-cycle Race Oil*)
- Turn the fuel on by rotating the fuel petcock knob to the vertically downward position (reserve position is horizontally forward)

CAUTION:

For best results from your Cobra Motorcycle use only the recommended fuels. Testing has shown that most 'race' fuels actually degrade performance.

When your pre-ride inspection is complete the bike may be started. For a cold engine follow this procedure.

1. Place the motorcycle on a stand of sufficient strength that positions the motorcycle in a level upright position with the rear wheel off the ground.
2. Pull up the choke knob and turn it to lock it.
3. Kick start the engine.
4. Rev the engine in short spurts, turning the throttle no more than 1/4 open until the engine will run without the choke.
5. Verify a functional engine shut-off switch by shutting off the engine.
6. Restart the engine and proceed with riding when the engine is sufficiently warm (i.e. the side of the cylinder is warm to touch).

CAUTION:

Never rev an engine full throttle when it's cold or slightly warmed up. Cobra recommends that you tell your child to take it easy the first couple of minutes in practice until the engine comes up to full operating temperature. Make sure your engine is properly warmed up before racing.

General Tips

1. Always wear a helmet and other protective riding gear.
2. Cobra recommends that you tell your child to take it easy the first couple of minutes in practice until the engine comes up to full operating temperature.
3. Make sure your riders' foot is not resting on the foot brake while they are riding.
4. Evaluate the bikes jetting only after it has been warmed up to race temperatures.
5. A properly maintained machine is safer, faster, and more fun to ride.
6. Cobra offers a carburetor inlet cover RCMU0109 to keep water and dirt from getting into the carburetor when the bike is being washed.
7. Your Cobra Motorcycle has a 10 digit VIN (Vehicle Identification Number). The first two digits indicate the model and the seventh indicates the model year (MY).
 - a. Example, CMxxxx4xxx is a 2004 MY CM50.

Maintenance

Schedule & Tips

It is important that you adhere to this maintenance schedule so as to promote the longevity of your Cobra Motorcycle.

- Between each ride
 - Check the air filter (clean and re-oil as necessary).
 - Insure the smooth operation of the throttle cable (throttle soundly 'clacks' shut).
 - Check for frayed strands of the throttle cable inside the throttle housing and replace if necessary.
 - Check for adequate tire pressures and adjust if necessary.
 - Check all nuts and bolts for proper torque and re-torque if necessary.
 - Spray all moving parts with WD40 or other light oil.
 - Check drive chain for
 - Proper tension and adjust if necessary.
 - Adequate lubrication and lubricate if necessary.
 - Insure that the ignition stator and rotor are clean and dry.
 - Check the frame for cracks in the metal or cracks in the paint that might indicate that the metal has been stressed beyond it's safe limits. Replace or get properly rewelded as necessary.
 - Inspect the rear sprocket damper plate for bending or warping. Straighten or replace if more than 1/16" (1.6 mm) from flat.
- Every 2 hours of operation
 - Replace the transmission oil.
- Every 10 hours of operation
 - Replace the fork oil.
 - Have the shock oil replaced by a Certified Cobra Mechanic.

CAUTION:

1. Because of the amount of heat generated by the clutch and engine during extended periods of riding, it is advisable to remove the ignition cover afterward to allow the ignition to cool off. The heat transfers through the cases and can damage the stator as it cools off because of lack of airflow around the stator.
2. If you ever need to weld anything on the bike, disconnect the spark plug cap, unplug the ignition, disconnect the kill switch, scrape the paint bare near the area to be welded and put the ground clamp as close to the area to be welded as possible.

⚠ WARNING

Be sure the fuel tank and carburetor have been removed and safely located away from the welding process.

3. The frame is 4130 Chrome Moly and it is important to weld it with the proper rod and heat settings set as light as possible. Cobra recommends replacing the frame with a new one if the old one becomes damaged.
4. If your kick-starter lever does not return to the rubber bumper, use WD-40 or light penetrating oil under the plastic cover behind the spring on the shaft. The shaft is a very close fit to the case and also has an O ring in it and is difficult to get lubrication to which may cause binding. If it does not loosen up, remove the kick-starter cover and kicking assembly. Grease the shaft.

M1: Replacing Transmission / Clutch Lubricant

Tools needed:

- 225 ml (7.6 oz) *Cobra Venom 3 Shoe Clutch Milk* (Part # MCMUGF01), or Dexron III Automatic Transmission Fluid.
- 13 mm combination wrench

Procedure:

1. Begin this procedure with a bike that has been ridden more than 5 minutes but less than 10 minutes. It is desired to have the engine warm enough so that the oil 'runny' but not so hot that there is risk of being burned by the engine or the oil.

⚠ WARNING

Hot oil and hot components on the motorcycle may cause burns.

2. Lean bike against something or set on stand with oil drain hole.
3. Using a 13 mm wrench, remove the oil drain bolt located on the right side of the engine, on the clutch cover, near the brake lever (Item 2, figure 1).

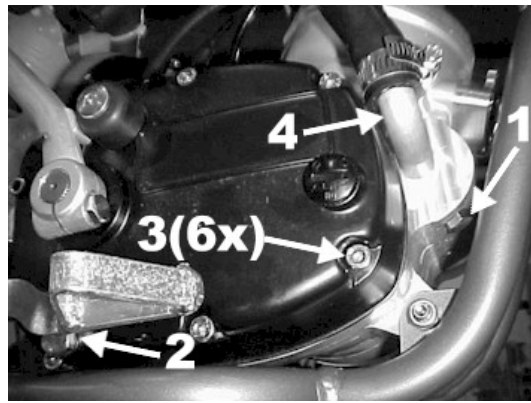

Figure 1

NOTE: You may need to adjust the brake pedal (up or down) to gain access to the drain bolt.

4. After it has drained, reinstall the bolt being sure that the copper gasket is in place. Torque to 15 Nm (11 ft-lb).
5. Reapply oil from oil fill plug 235 cc *Cobra Venom 3 Shoe Clutch Milk*, or Dexron III Automatic Transmission Fluid, thru the fill plug.

NOTE:

Lean bike over onto it's left hand side so that the clutch cover is up unless you have a squeeze bottle.

6. Reapply the oil fill bolt, hand tight, being sure the fiber gasket is in place.

CAUTION:

Cobra has spent considerable time and money developing the proper lubrication to handle the harsh environment of the automatic clutch and transmission of this motorcycle. Cobra's specially developed *Cobra Venom 3 Shoe Clutch Milk* (Part # MCMUGF01) was formulated to provide superior lubrication and cooling capability over extended periods of time and is the recommended lubricant for your Cobra motorcycle.

M2: Chain adjustment



Figure 2

1. Make sure that the rear wheel is aligned properly.
2. Push down on the seat, compressing the suspension down to where the chain is tightest.
3. The chain should not be too tight but not too loose. A minimum of 2.5 in. of slack should be between the swing arm and the chain.

M3: Front brake adjustment

Tools recommended for front brake maintenance:

- 10mm open end wrench



Figure 3, from the brake lever

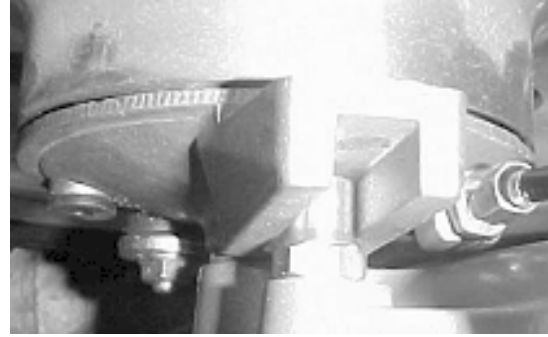

Figure 4, from the brake hub

From the brake lever:

1. Loosen the locking nut on the brake lever.
2. Adjust the bolt to desirable position.
3. Tighten the locking nut.

From the brake hub:

1. Loosen the 10mm nut on the hub.
2. Adjust the brake cable to desirable position
3. Tighten the 10mm nut.

CAUTION:

If you tighten the front brake up too much, the brakes may hang up causing the brake pads to wear incorrectly and prematurely.

M4: Rear brake adjustment

Tools recommended for rear brake maintenance:

- 10mm open end wrench

There are 2 adjustments on the brake.



Figure 5, adjust brake lever free height



Figure 6, adjust brake lever 'free play'

From the brake lever:

4. Loosen the 10mm nut on the back of the brake pedal.
5. Adjust the bolt to desirable position
6. Tighten the 10mm nut.

From the brake hub:

1. Adjust the wing nut up to desirable position.

CAUTION:

If you tighten the wing nut up too much, the brakes may hang up. If so, the brake pads will burn up, and need replaced.

M5: Air Filter Cleaning

Tools recommended for air filter maintenance:

- #2 Phillips head screwdriver
- 4 mm hex key (Allen)
- Foam filter oil

Procedure

1. Removed the seat with the 4 mm hex key
2. Remove the filter/air inlet boot from the back of the carburetor with a flat screwdriver
3. Pull the filter / boot assembly back, up, and out the top of the airbox.
4. Clean the filter in a nonflammable solvent to remove the filter oil.

 WARNING

Do not clean the air filter with gasoline or other highly volatile petroleum product. Diesel fuel or kerosene would be preferred but caution should still be taken. Hot soapy water works well.

5. Clean the filter in hot soapy water to remove all dirt particles.
6. Allow it to dry thoroughly.
7. Saturate with filter oil and remove excess.

NOTE:

The Cobra is equipped with a special designed Air box. It is very important to keep the air filter clean and properly oiled with high quality water-resistant foam filter oil. It's very important to oil your filter consistently each time because varied amounts of oil will change your carburetor jetting.

8. **Reinstall** the filter / boot assembly by pushing it down and forward into the airbox making sure the letters "PW" are visible between the carburetor and airbox (figure 8).



Figure 8

NOTE:

Make sure you change or clean your filter after each moto. We recommend carrying multiple filters in your toolbox, one for each practice session and moto.

M6: Fork Oil Replacement

Tools required

- 5 & 6 mm Allen wrench
- 19 mm wrench or socket (two required)
- Spring clip remover

Disassembly

1. Remove the front wheel.
2. Remove the fork legs from the triple clamps.
3. Perform the following on one leg at a time.
4. Using your hands, remove the black rubber plug from the top of the fork leg exposing the white plastic cap.
5. Secure the fork leg assembly in a vice by gripping the leg across the flats through which the axle bolt goes through.
6. Depress the white plastic cap inwards (down) and remove the wire spring clip from its groove.
7. Remove the white cap, the fork spring preload sleeve, and the fork spring.

NOTE: Depressing the fork leg will facilitate removing the white cap.

8. The fork can now be turned upside down and drained.

Assembly

1. Fill the leg with 200 cc (6.8 oz) 20 wt fork oil.
2. Standard fork oil level is 70 mm (2.75") from the top edge with the fork collapsed.

NOTE: Remove the preload sleeve but leave the spring in for the measurement.

3. Install the preload sleeve.
4. Install and depress the white cap while installing the spring clip.
5. Fork may be reinstalled.

Parts

Parts – Airbox and Inlet System

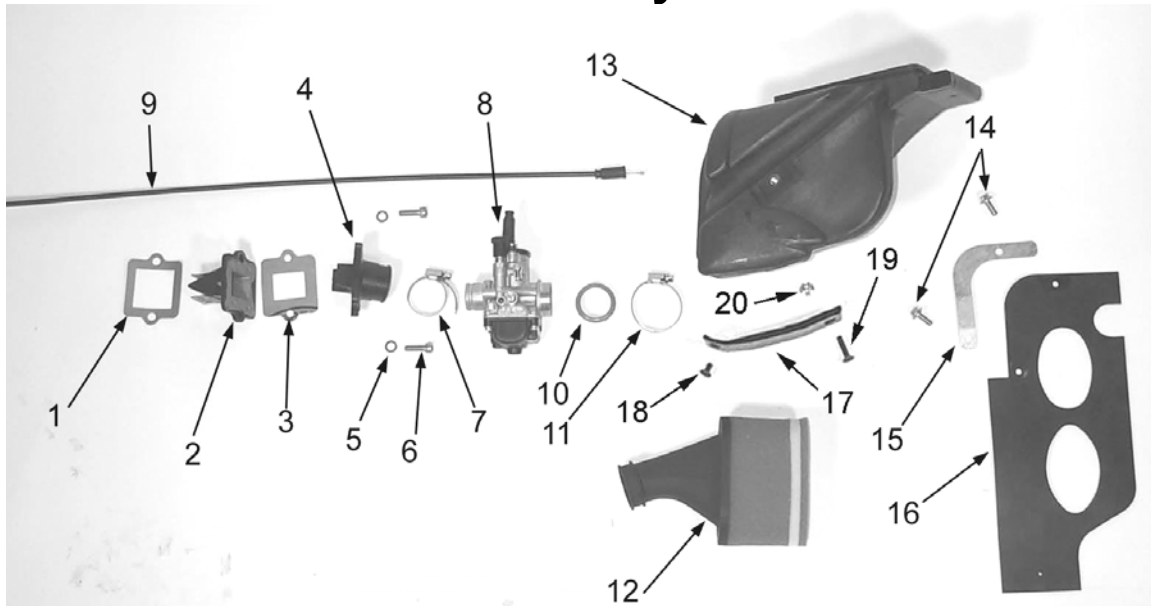

Figure 7

Airbox and Inlet System		
REF #	PART #	DESCRIPTION
1	ZCMU0032	GASKET – REED TO CYLINDER
2	ECKG0205	REED VALVE
3	ZCMU0031	GASKET – MANIFOLD TO REED
4	ECKG0203	INLET MANIFOLD
5	HCWF0601	6MM FLAT WASHER
6	HCBC0625	M6X25 SOCKET HEAD CAP SCREW
7	MCKGHO01	HOSE CLAMP – CARBURETOR TO MANIFOLD
8	RACM0002	CARBURETOR 14MM
9	FCMU0019	THROTTLE CABLE
10	RCCM1301	VELOCITY STACK
11	MCKGHO01	HOSE CLAMP – AIR BOOT TO CARBURETOR
12	RCMU0403	AIR FILTER WITH BOOT
13	RCMU0405	AIR BOX – CM
14	HCBB0612	M6X12 BUTTON HEAD BOLT (2 REQ'D)
15	RCMU1407	BRACKET – MUD FLAP
16	RCMU0406	MUD FLAP – CM

Parts – Bars and Controls

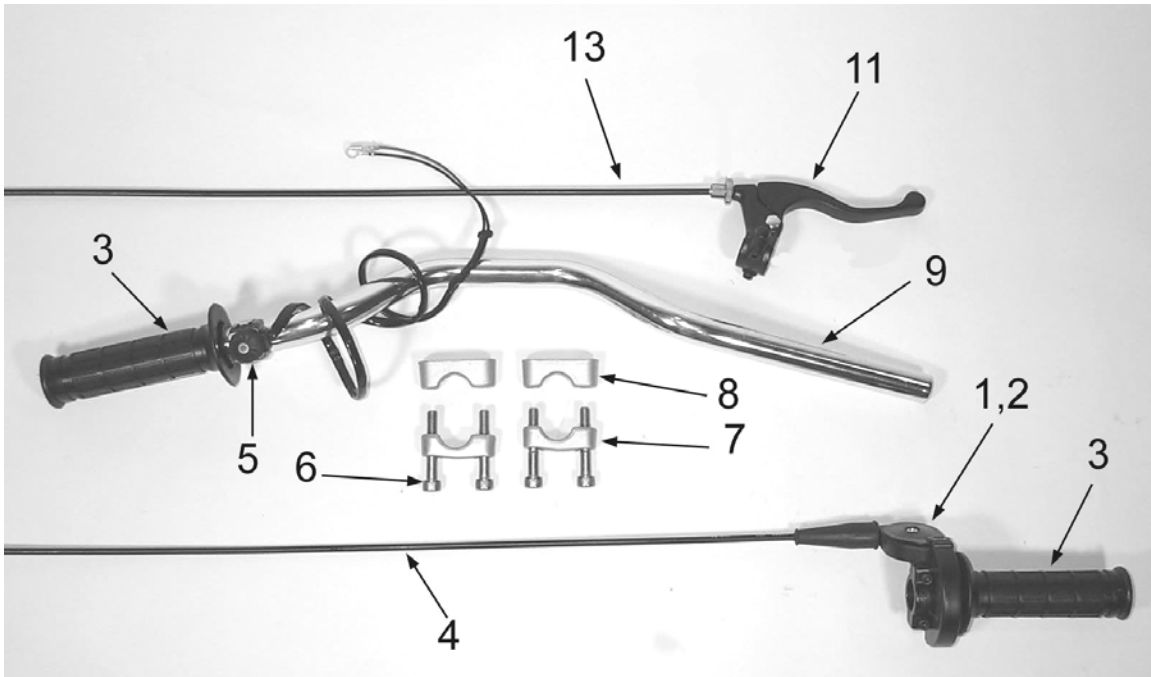

Figure 8

Bars and Controls		
REF #	PART #	DESCRIPTION
1	FCMU0066	THROTTLE ASSEMBLY
2	FCMU0068	THROTTLE COVER
3	TCMU0008	GRIPS (SET OF TWO)
4	FCMU0019	THROTTLE CABLE
5	FCMU0033	KILL SWITCH ASSEMBLY
6	KCMZ0001	M8X50 SOCKET HEAD CAP SCREW (4 REQ'D)
7	KCMZ0003	LOWER HANDLE BAR CLAMP (2 REQ'D)
8	KCMZ0002	TOP HANDLE BAR CLAMP (2 REQ'D)
9	TCMU0019	HANDLEBAR - ALUMINUM
11	BCMU0100	BRAKE LEVER / PERCH ASSEMBLY WITH ADJUSTER
13	BCMU0108	FRONT BRAKE CABLE

Parts - Carburetor

Carburetor		
REF. #	PART #	DESCRIPTION
	RCCM0001	COMPLETE CARBURETOR 14MM
1	RCMU0305	CARB SLIDE
2	RCMU0601	NEEDLE
3	RCMU0002	ATOMIZER
4	RCMU0092	MAIN JET
5	RCMU0055	PILOT JET
6		CHOKE JET
7	RCMU0301	FLOAT
8	RCMU0102	RUBBER CABLE CAP SEAL
9	RCMU0003	CABLE ADJUSTER
11	RCMU0006	TOP CARB SCREW
12	RCMU0106	CARB TOP
13	ZCMU0007	TOP CARB GASKET
14	RCMU0004	SLIDE SPRING
15	RCMU0028	NEEDLE RETAINER PLATE
16	RCMU0007	NEEDLE CLIP
17	RCMU0204	CHOKE ASS'Y. 2001 CM
20	RCMU0009	FUEL MIXTURE SCREW
21	RCMU0011	IDLE ADJUSTMENT SCREW
25	RCMU0103	FLOAT BOWL GASKET
26	RCMU0107	FLOAT NEEDLE
27	RCMU0012	DIFFUSER
28	RCMU0016	FLOAT RETAINER PIN
29	RCMU0108	FLOAT BOWL
30	HCWF0401	WASHER 4MM FLAT
31	RCMU0201	SCREW FLOAT BOWL
33	RCCM1301	VELOCITY STACK
	RCCM0314	14MM CARB RESTRICTOR

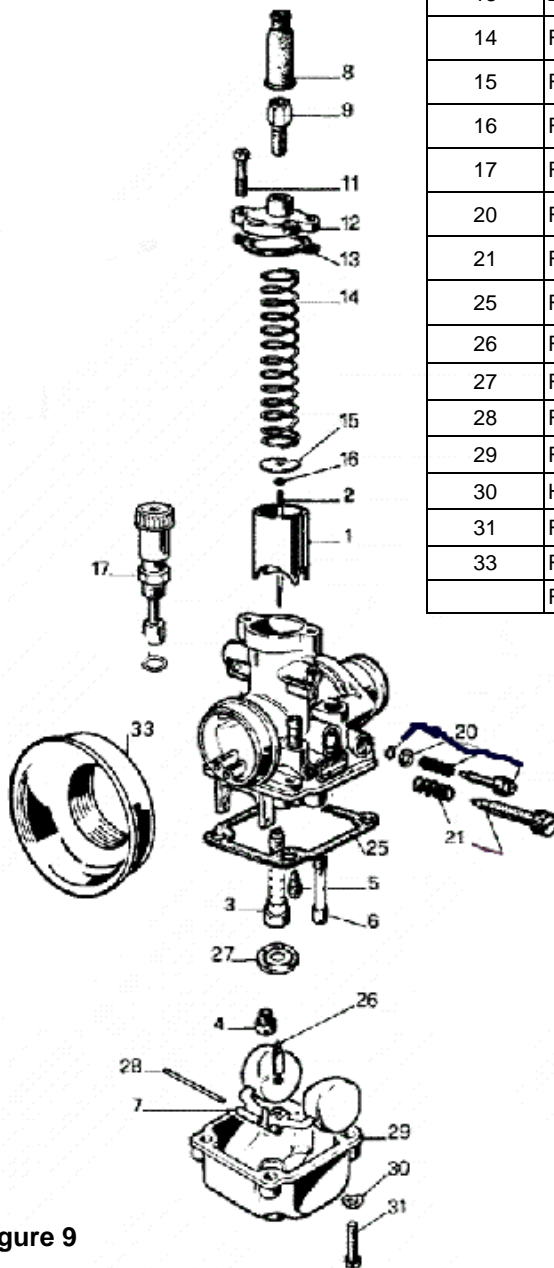

Figure 9

Parts – Coolant System

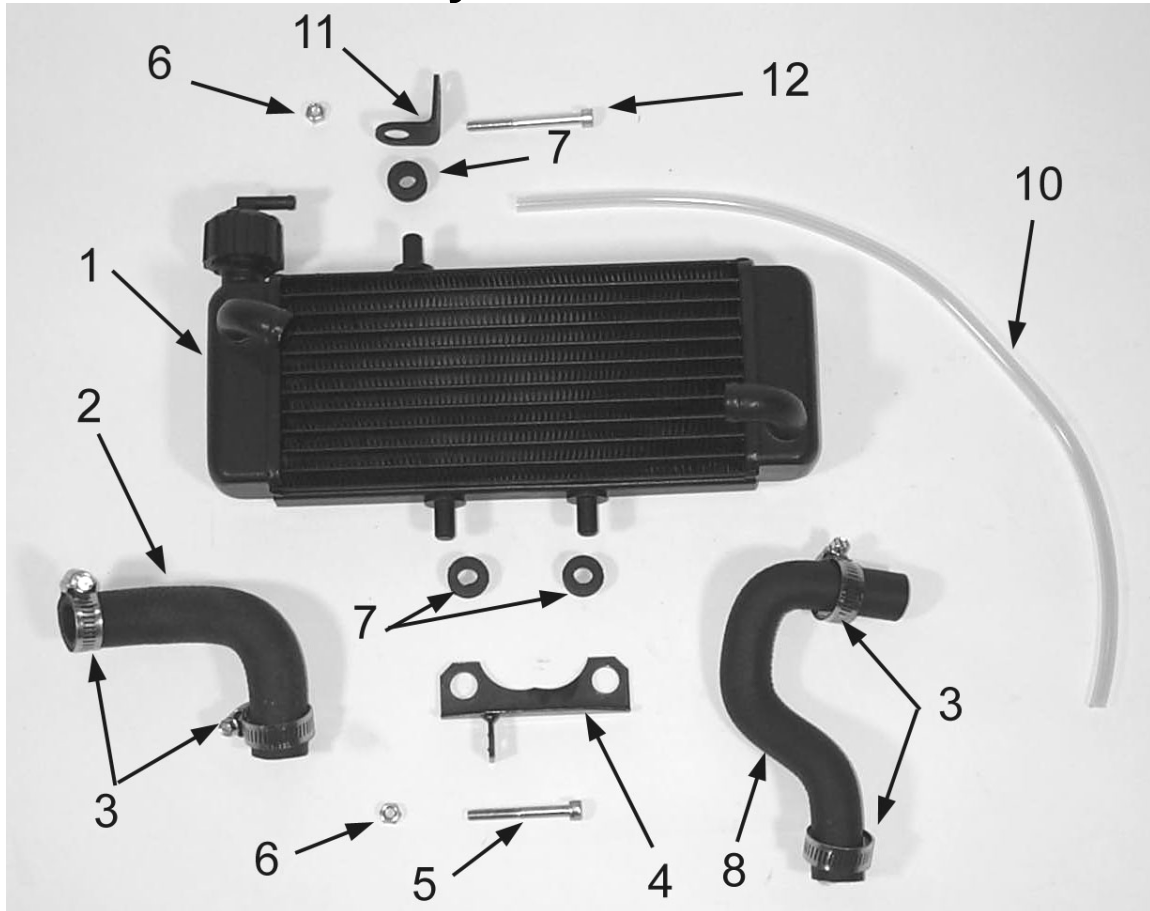

Figure 10

Coolant System		
REF #	PART #	DESCRIPTION
1	ECMU0061	RADIATOR WITH CAP
2	MCMUHO02	RADIATOR HOSE LEFT
3	MCMUCL02	HOSE CLAMP
4	ECHA0003	MOUNTING BRACKET – RADIATOR BOTTOM
5	HCBC0607	M6X50 SOCKET HEAD CAP SCREW
6	HCNL0601	6MM LOCK NUT
7	MCKGGR00	GROMMET – RADIATOR MOUNTING
8	MCMUHO03	RADIATOR HOSE RIGHT
10	ECHA0002	OVERFLOW HOSE
NOT SHOWN	MCMUCL05	HOSE CLAMP FOR OVERFLOW HOSE
11	ECHA0109	MOUNTING BRACKET – RADIATOR TOP
12	HCBC0660	M6X60 SOCKET HEAD CAP SCREW

Parts – Electrical System

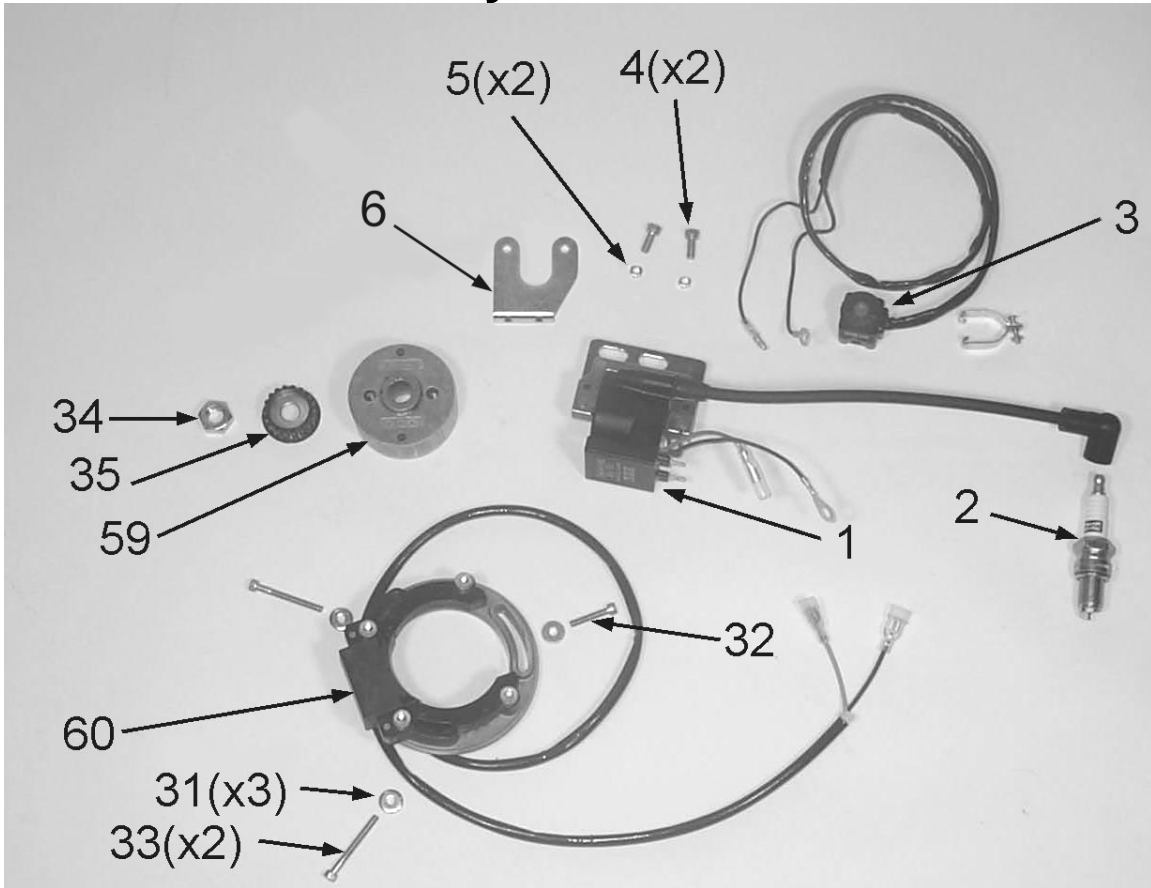

Figure 11

Electrical System		
REF #	PART #	DESCRIPTION
1	IAMU0001	COIL W/SPARK PLUG CAP
2	ECMU0065	SPARK PLUG, CHAMPION (8339-1)
2H	ECMU0067	OPTIONAL HOTTER PLUG (8332-1)
2C	ECMU0066	OPTIONAL COLDER PLUG (8904-1)
3	FCMU0033	KILL SWITCH ASSEMBLY
4	HCBC0516	SCREW, M5 X 16 (2 PER)
5	HCNL0601	6MM LOCK NUT
6	ECMU1210	BRACKET – COIL MOUNT
31	HCWP0001	WASHER FOR STATOR (3 PER)
32	HCBC8312	SOCKET HEAD CS, 8-32X1
33	HCBC0801	SOCKET HEAD CS, 8-32X 1-1/2 (2 PER)
34	HCNS1001	NUT 10MM
35	ECKG0042	PULLEY, WATERPUMP CRANK
59	ICMU0006	ROTOR
60	ICMU0007	STATOR
NOT SHOWN	MCKGGR00	GROMMET - STATOR LEAD
NOT SHOWN	ICMU0012	ROTOR SHAFT KEY

Parts – Engine – Bottom End and Transmission

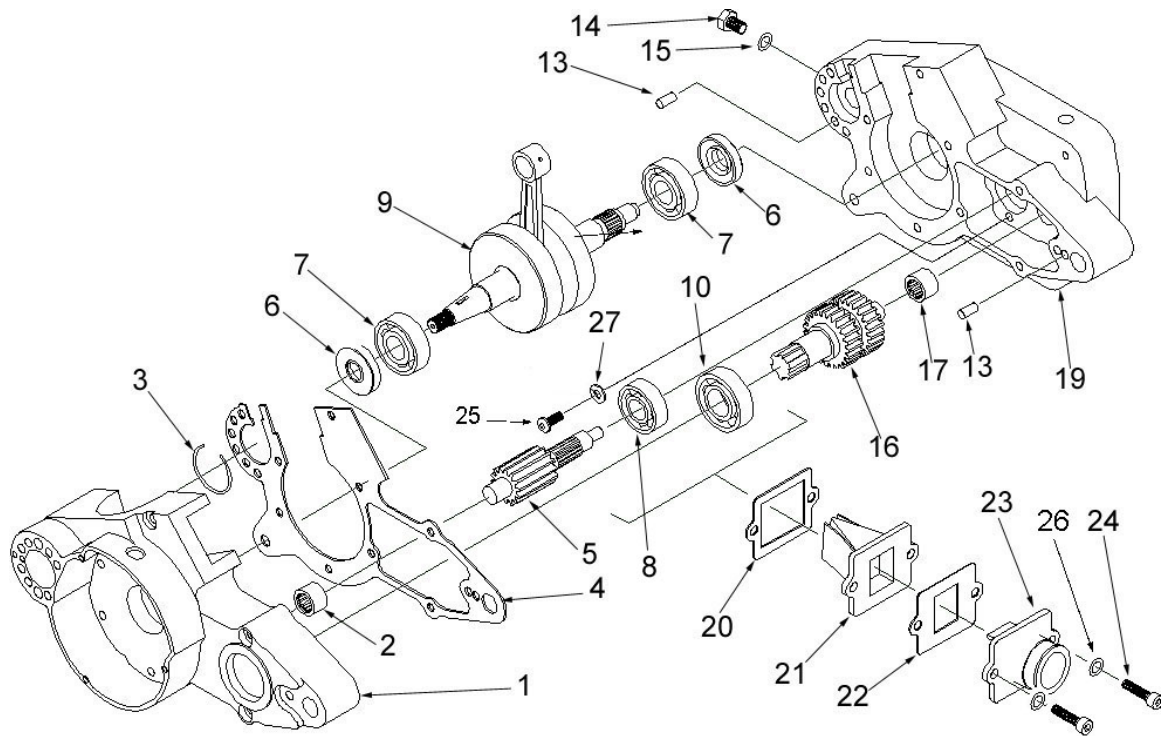

Figure 12

Engine Bottom End and Transmission		
REF #	PART #	DESCRIPTION
1	EKMU2004	CRANKCASE SET NO B&S 2004
2	ECMU0020L	BEARING, TRANSMISSION PRECISION
3	ECKG0004	SNAP RING, WATER PUMP
4	ZCKG2001	GASKET, CRANKCASE
5	ECMU0103	SECONDARY SHAFT, TRANSMISSION WITH GEAR
6	ECMU0017	SEAL, CRANKSHAFT
7	ECMU0016	BEARING, CRANKSHAFT
8	ECMU0001	BEARING, TRANSMISSION SECONDAY SHAFT
9	ECMU0038	CRANKSHAFT
10	ECKGBR01	BEARING, TRANSMISSION OUTPUT SHAFT
13	HCDP1401	DOWEL, ENGINE CASE ALIGNEMENT
14	HCBH0805	M8X12 SCREW
15	HCWC0000	COPPER GASKET
16	ECMU0104	OUTPUT SHAFT, TRANSMISSION WITH GEAR
17	ECMU0020	BEARING, TRANSMISSION PRECISION
19	EKMU2004	CRANKCASE SET NO B&S 2004
20	ZCMU0032	GASKET, REED TO CASE
21	ECKG0202	REED ASSEMBLY
NOT SHOWN	ECKG0205	REED KIT
22	ZCMU0031	GASKET, INTAKE TO REED
23	ECKG0203	INTAKE MANIFOLD
24	HCBC0602	SCREW M6X20
25	HCBH0612	M6X12 HEX HEAD BOLT - BEARING RETAINER
26	HCWF0601	6MM FLAT WASHER
27	HCWL0601	6MM LOCK WASHER

Parts –
Engine –
Clutch
and Kick
Starter

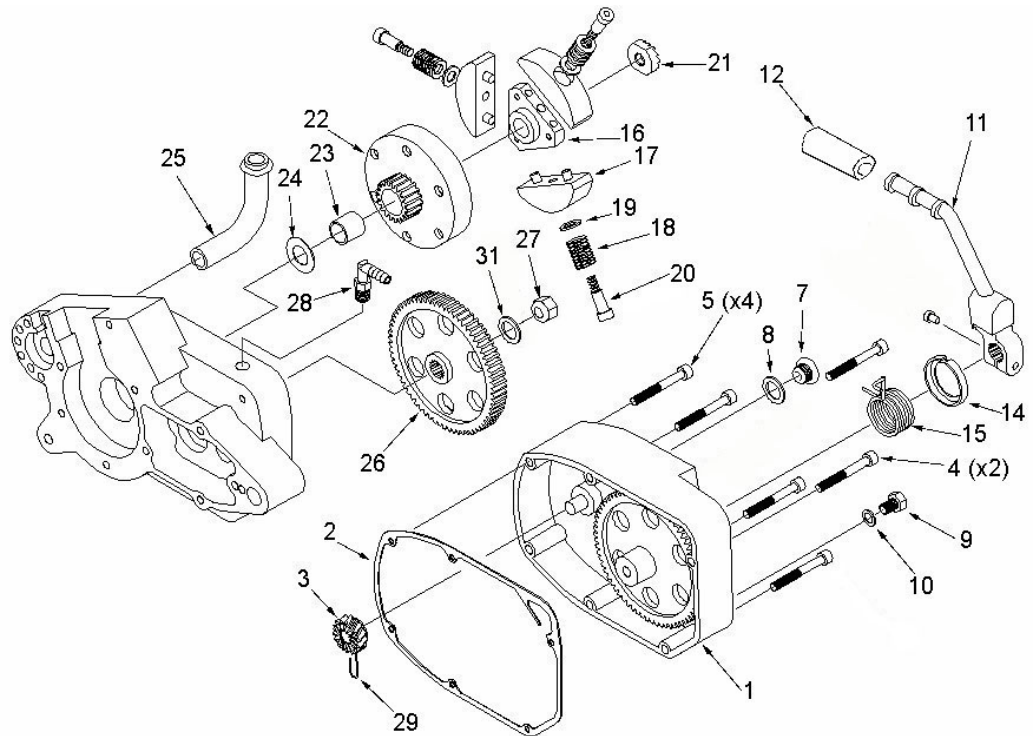

Figure 13

Engine – Clutch and Kick Starter		
REF #	PART #	DESCRIPTION
1	ECMU0027	CLUTCH COVER COMPLETE WITH KICK LEVER
2	ZCMU0030	CLUTCH COVER GASKET
3	ECMU0207	KICKSTART GEAR SMALL
4	HCBC0608	M6X55 SHCS CLUTCH CVR SCREW LNG (2 REQD) CENTER
5	HCBC0606	M6X45 SHCS CLUTCH COVER SCREW SHORT (4 REQD)
7	ECMU0037	OIL FILL PLUG
8	ZCMU0001	OIL FILL PLUG GASKET
9	HCBH0805	M8X12 OIL DRAIN SCREW
10	HCWC0000	COPPER GASKET
11	ECMU0202	LEVER – KICK START
12	ECMU0205	RUBBER – KICK START LEVER
14	ECMU0204	KICK START DUST COVER
15	ECMU0403	SPRING – KICK LEVER
16	CCMU0031	CLUTCH ARBOR
17	CAKG0005	CLUTCH SHOE (SET OF 3)
NOT SHOWN	CAKG0004	SET OF 3 CLUTCH SHOES WITH SPRINGS, WASHER & BOLT
NOT SHOWN	CAKG0002	CLUTCH ASSY W/ ARBOR, SHOES, SPRINGS, WSHR & BOLT
18	CCMU0129	SPRING, CLUTCH (SINGLE PIECE)
19	HCWS0801	WASHER, CLUTCH (SINGLE PIECE)
NOT SHOWN	CAMU0008	SPRINGS, WASHER, & BOLT (COMPLETE SET FOR 3 SHOES)
20	HCBS5603	BOLT, CLUTCH CENTER (SINGLE PIECE)
21	ECMU0018	NUT, CLUTCH SPECIAL
22	ECMU0033	CLUTCH BASKET NON WELDED WITH BUSHING
23	ECMU0003	BUSHING, CLUTCH BASKET
24	ECMU0040	SPACER, CLUTCH BASKET (1 - 3 REQD)
25	ECMU0131	WATER ELBOW
26	ECMU0105	GEAR, PRIMARY TRANSMISSION
27	HCNS1202	NUT, 1/2-20 LEFT HAND THREAD
28	ECDC0105	ELBOW, CASE VENT
NOT SHOWN	ECDC1106	HOSE – CRANKCASE VENT
29	ECMUSP01	KICK START DOG SPRING (PAPER CLIP)
31	HCWB0042	SPRING WASHER

Parts –
Engine –
Ignition
and Water
Pump

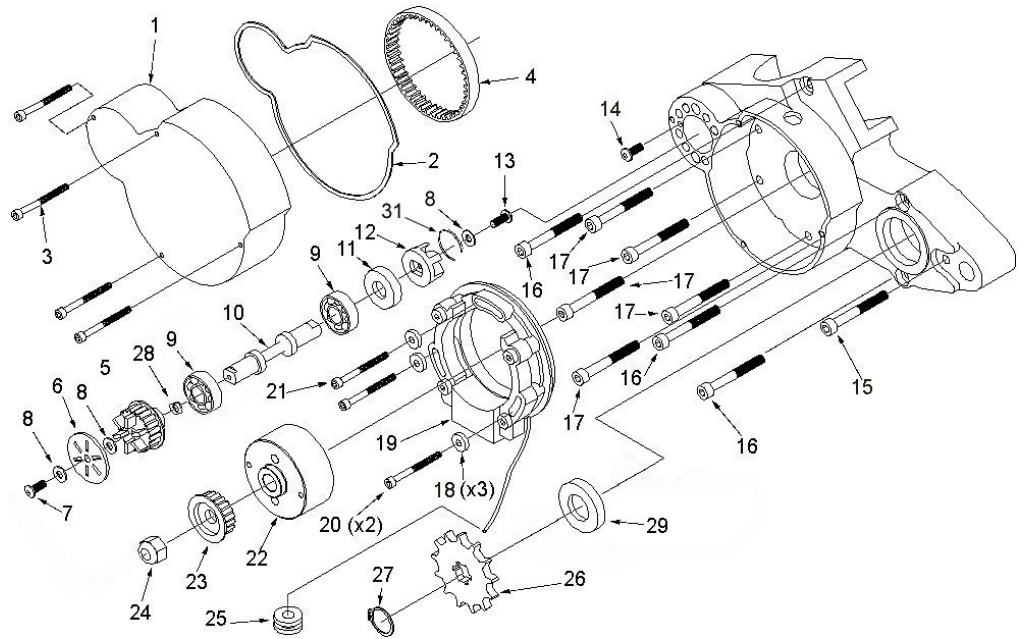

Figure 14

Engine – Ignition and Water Pump		
REF #	PART #	DESCRIPTION
1	ECKG0001	IGNITION COVER
2	ZCKG0101	IGNITION COVER GASKET
3	HCBC0802	COVER SCREW, SHCS 802X1-3/4
4	ECKG0070	WATER PUMP BELT
5	ECKG0075	WATER PUMP PULLEY, FAN TYPE - DRIVEN
6	ECMU0080	BELT RETAINER
7	HCBC1033	PULLEY SCREW, SHCS 10-32X3/4
8	HCWF0501	FLAT WASHER
9	ECKG0072	BEARING, WATER PUMP
10	ECKG0141	SHAFT, WATER PUMP
11	ECKG0074	SEAL, WATER PUMP SHAFT
12	ECKG0073	IMPELLER, WATER PUMP
13	HCBB0001	IMPELLER SCREW, SHCS 10-32X1/2
14	HCSS8201	RETAINING SCREW, SHCS 8-32X3/8
15	HCBC0603	CASE SCREW, SHCS M6X30
16	HCBC0606	CASE SCREW, SHCS M6X45 (3 REQD)
17	HCBC0604	CASE SCREW, SHCS M6X35 (5 REQD)
18	HCWP0001	WASHER, STATOR (3 REQD)
19	ICMU0007	STATOR
20	HCBC0801	STATOR SCREW, SHCS 8-32X1-1/2 (2 REQD)
21	HCBC8321	STATOR SCREW, SHCS 8-32X1
22	ICMU0006	ROTOR
NOT SHOWN	ICMU0012	WOODRUFF KEY – FLYWHEEL / CRANKSHAFT
23	ECKG0042	WATER PUMP PULLEY, CRANK
24	HCNS1001	NUT 10MM
25	MCKGGR00	GROMMET
26	PCKG0013	SPROCKET, 13T COUNTERSHAFT
27	ECKGSR03	SNAP RING, COUNTERSHAFT SPROCKET
28	HCWF0503	SPACER – WATER PUMP PULLEY
29	ECKGSE01	SEAL, COUNTERSHAFT
31	ECKG0004	RETAINER, WATER PUMP ASSEMBLY

Parts –
Engine – Top
End

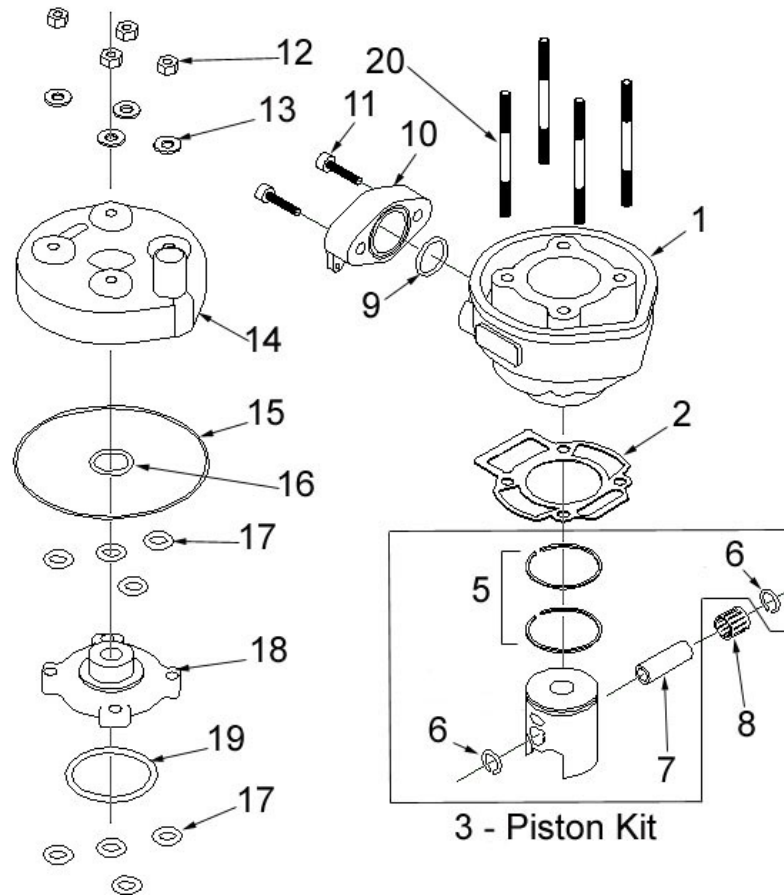

Figure 15

Engine – Top End		
REF #	PART #	DESCRIPTION
1	ECKG0041	CYLINDER
2	ZCKG0002	BASE GASKET
3	ECMU0043	PISTON KIT
5	ECMU0055	PISTON RINGS (2 PER SET)
6	ECMUSR00	SNAP RING FOR PISTON (2 REQ'D)
7	ECKG0012	WRIST PIN
8	ECMU0077	BEARING, WRIST PIN
9	ZCMUOR07	O'RING, EXHAUST FLANGE
10	ECKG0015	EXHAUST FLANGE
11	HCBC0612	M6X20, EXHAUST FLANGE SCREW (2 REQ'D)
12	HCNS1401	NUT, CYLINDER HEAD 1/4-20 (4 REQ'D)
13	HCWF1401	FLAT WASHER, 1/4" (4 REQ'D)
14	ECKG0026	CYLINDER HEAD OUTER
15	ZCMUOR02	O'RING, CYLINDER HEAD LARGE
16	ZCMUOR08	O'RING CYLINDER HEAD SMALL
17	ZCMUOR03	O'RING CYLINDER STUD (8 REQ'D)
18	ECKG1121	CYLINDER HEAD, INSERT
19	ZCMUOR05	O'RING CYLINDER HEAD MEDIUM
20	ECMU0008	STUD, CYLINDER

Parts – Exhaust System

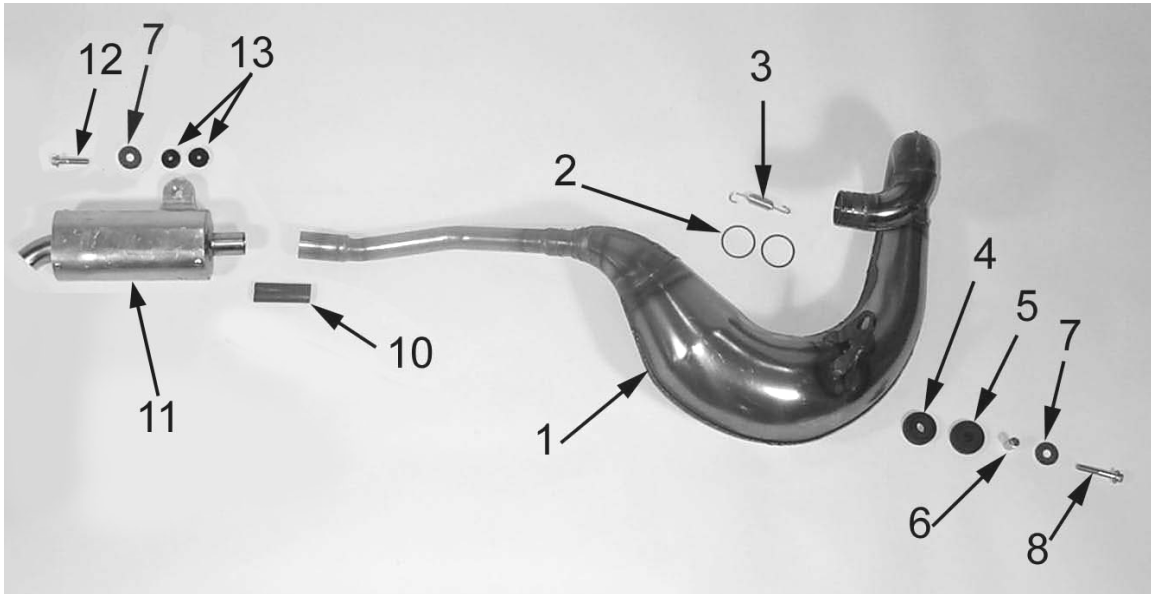

Figure 16

Exhaust System		
REF #	PART #	DESCRIPTION
1	XCCM2004	2004 CM EXHAUST PIPE
2	ZCMUOR30	HEADER PIPE O-RINGS (2 REQ'D)
3	XCMU0005	EXHAUST SPRING - SHORT
4	MCMUGR06	PIPE GROMMET MALE
5	MCMUGR07	PIPE GROMMET FEMALE
6	MCMUSP02	PIPE GROMMET SPACER
7	HCWF1478	PIPE GROMMET WASHER
8	HCBF0635	M6X35 FLANGE HEAD BOLT
10	XCKG0009	PIPE / SILENCER SEAL
11	XCKG0003	SILENCER
NOT SHOWN	XCMU0027	SILENCER PACKING KIT
12	HCBF0630	M6X30 FLANGE HEAD BOLT
13	MCMUGR04	GROMMET – SILENCER MOUNTING (2 REQ'D)

Parts – Forks & Triple Clamps

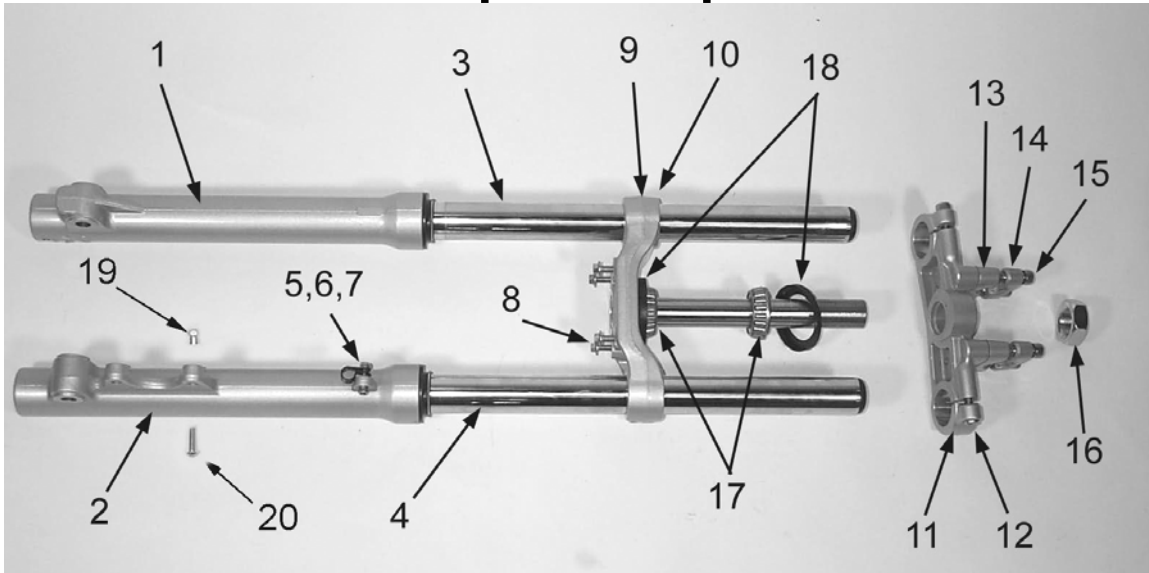

Figure 17

Front Forks and Triple Clamp		
REF #	PART #	DESCRIPTION
1	KCMZ0029	OUTER FORK LEG – RIGHT (NON BRAKE) SIDE
NOT SHOWN	KCMZ0131	OUTER FORK LEG ASSY – RIGHT WITH SEAL & SWIPER
2	KCMZ0020	OUTER FORK LEG – LEFT (BRAKE) SIDE
NOT SHOWN	KCMZ0121	OUTER FORK LEG ASSY – LEFT WITH SEAL & SWIPER
3	KCMZ0026	INNER FORK LEG – RIGHT (COMPRESSION) SIDE
4	KCMZ0027	INNER FORK LEG – LEFT (REBOUND) SIDE
5	HCCC0001	CLAMP – BRAKE CABLE
6	HCBC0502	M5X20 SOCKET HEAD CAP SCREW
7	HCNL0501	5MM LOCK NUT
8	HCBF0616	FENDER BOLT, M6X16 FLANGE HEAD (4 REQD)
9	KCMZ0025	TRIPLE CLAMP – LOWER WITH STEM
10	HCBC0625	M6X25 SOCKET HEAD CAP SCREW (4 REQD)
11	KCMZ0005	TRIPLE CLAMP – UPPER (NO BAR MOUNTS)
12	HCBC0806	M8X30 SOCKET HEAD CAP SCREW (2 REQD)
13	KCMZ0003	BAR MOUNT – LOWER (2 REQ'D)
14	KCMZ0002	BAR MOUNT – UPPER (2 REQ'D)
15	KCMZ0001	M8X50 SOCKET HEAD CAP SCREW
16	HCNJ0101	STEERING HEAD NUT 1X14
17	FCMU0004	STEERING HEAD BEARING (2 REQD)
18	FCMU1103	DUST COVER (2 REQD)
19	BCMU0007	BRAKE STOP
20	HCBH0808	M8X30 BUTTON HEAD SCREW

Parts –
Forks –
Leg
Assembly

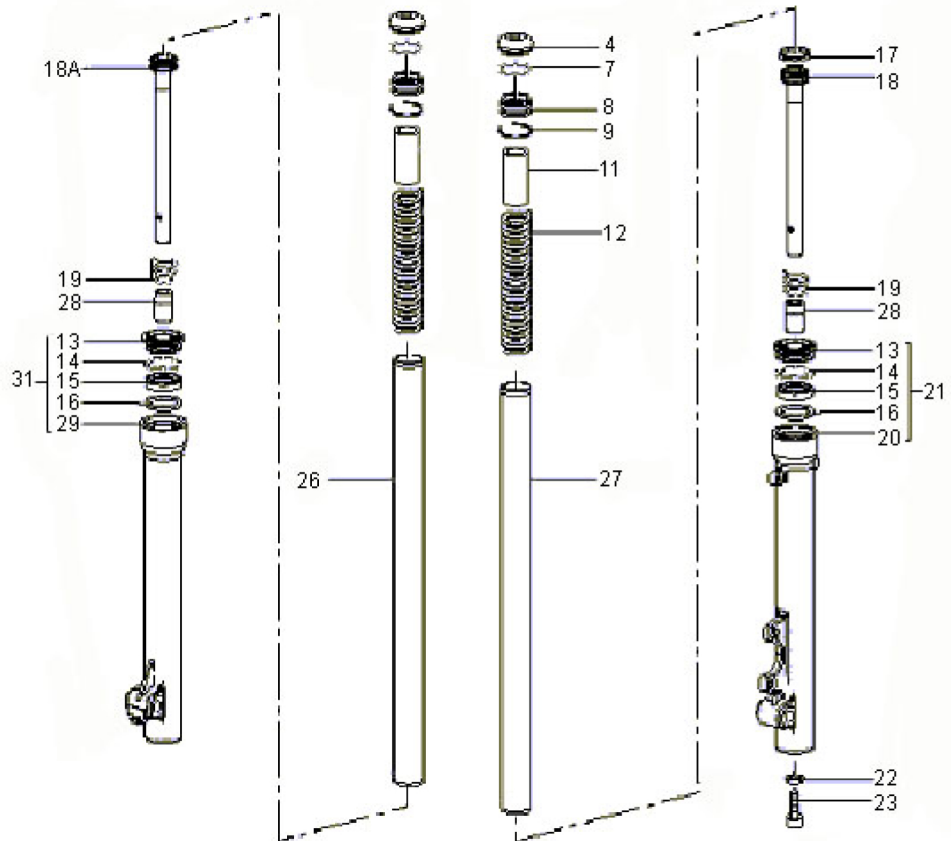

Figure 18

REF #	PART #	DESCRIPTION
4	KCMZ0004	FORK PLUG – BLACK
7	KCMZ0007	SNAP RING FOR FORK CAP
8	KCMZ0008	INNER FORK CAP - WHITE
9	KCMZ0009	O-RING UNDER FORK CAP
11	KCMZ0111	PRELOAD SLEEVE
12	KCMZ0012	FORK SPRING
13	KCCS0004	FORK SEAL & SWIPER KIT
14	KCMZ0014	SNAP RING
15	KCCS0004	FORK SEAL & SWIPER KIT
16	KCMZ0016	WASHER
17	KCMZ0017	SEALING RING FOR REBOUND PISTON
18	KCMZ0118	PISTON ROD - REBOUND
18A	KCMZ0118A	PISTON ROD - COMPRESSION
19	KCMZ0019	REBOUND SPRING
20	KCMZ0020	FORK LEG OUTER LEFT
21	KCMZ0021	FORK LEG – 5 PIECE UNIT – LEFT
22	HCWC0000	WASHER
23	HCBC0806	8 X 30 CS
26	KCMZ0026	FORK TUBE – INNER RIGHT
27	KCMZ0027	FORK TUBE – INNER LEFT
28	KCMZ0028	TOP OUT BUMPER
29	KCMZ0029	FORK LEG – OUTER RIGHT
31	KCMZ0031	FORK LEG – 5 PIECE UNIT – RIGHT
32	HCBC0609	6 X 20 CS

Parts – Frame – Mounting Hardware I

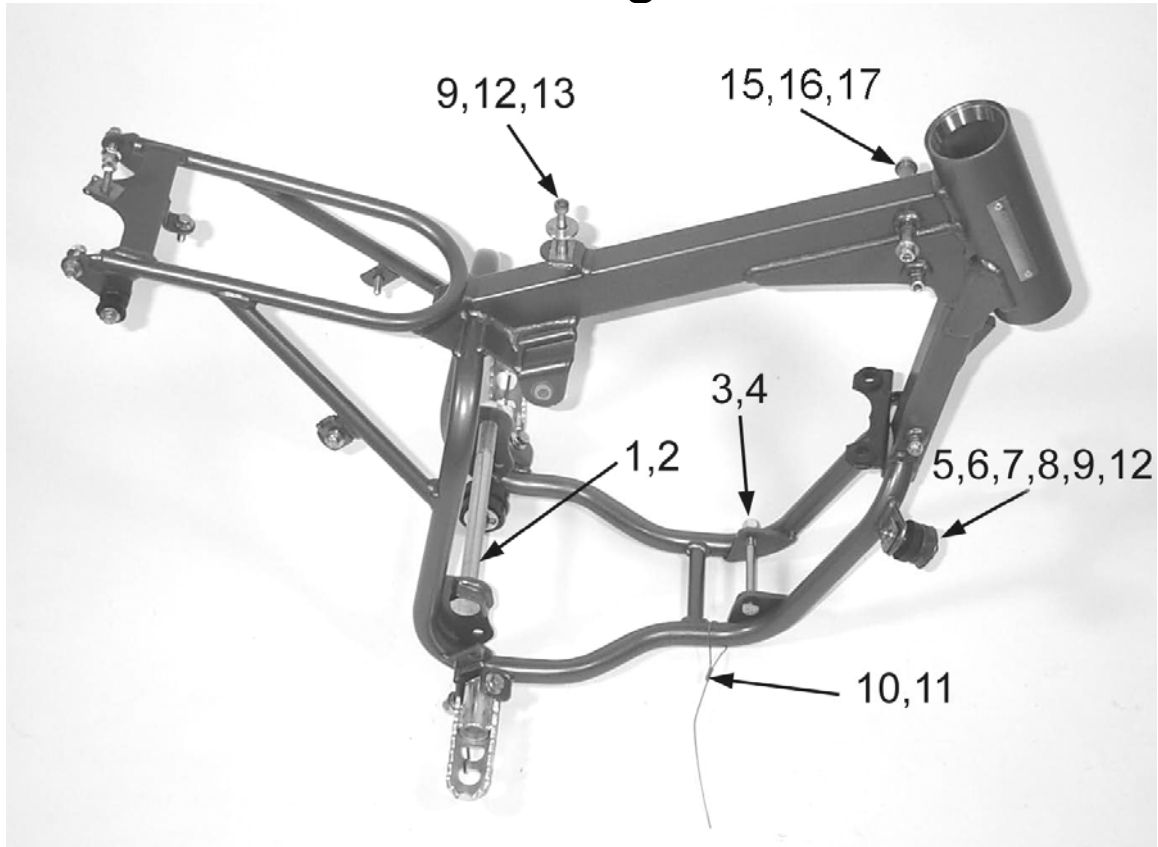

Figure 19

Frame – Engine, Tank, and Pipe Mounts, Brake Snake		
REF #	PART #	DESCRIPTION
	FAMU0004	FRAME 2004 CM50
1	HCBH1403	SWINGARM BOLT
2	HCNL1402	SWINGARM LOCK NUT (M14X1)
3	HCBH0880	M8X80 SOCKET HEAD CAP SCREW
4	HCNL0801	8MM LOCKNUT
5	MCMUGR06	PIPE GROMMET MALE
6	MCMUGR07	PIPE GROMMET FEMALE
7	MCMUSP02	PIPE GROMMET SPACER
8	HCWF1478	PIPE GROMMET WASHER
9	HCHA0003	6MM CLIPNUT
10	BCMU0008	CABLE – BRAKE SNAKE
11	BCMU0009	CRIMP – BRAKE SNAKE
12	HCBF0635	M6X35 FLANGE HEAD BOLT
13	TCHA0004	BUSHING – REAR TANK MOUNTING
15	HCNL0601	6MM LOCKNUT
16	TCHA0006	BUSHING – FRONT TANK MOUNT (2 REQ'D)
17	HCBF0685	M6X85 SHCS

Parts – Frame – Mounting Hardware II

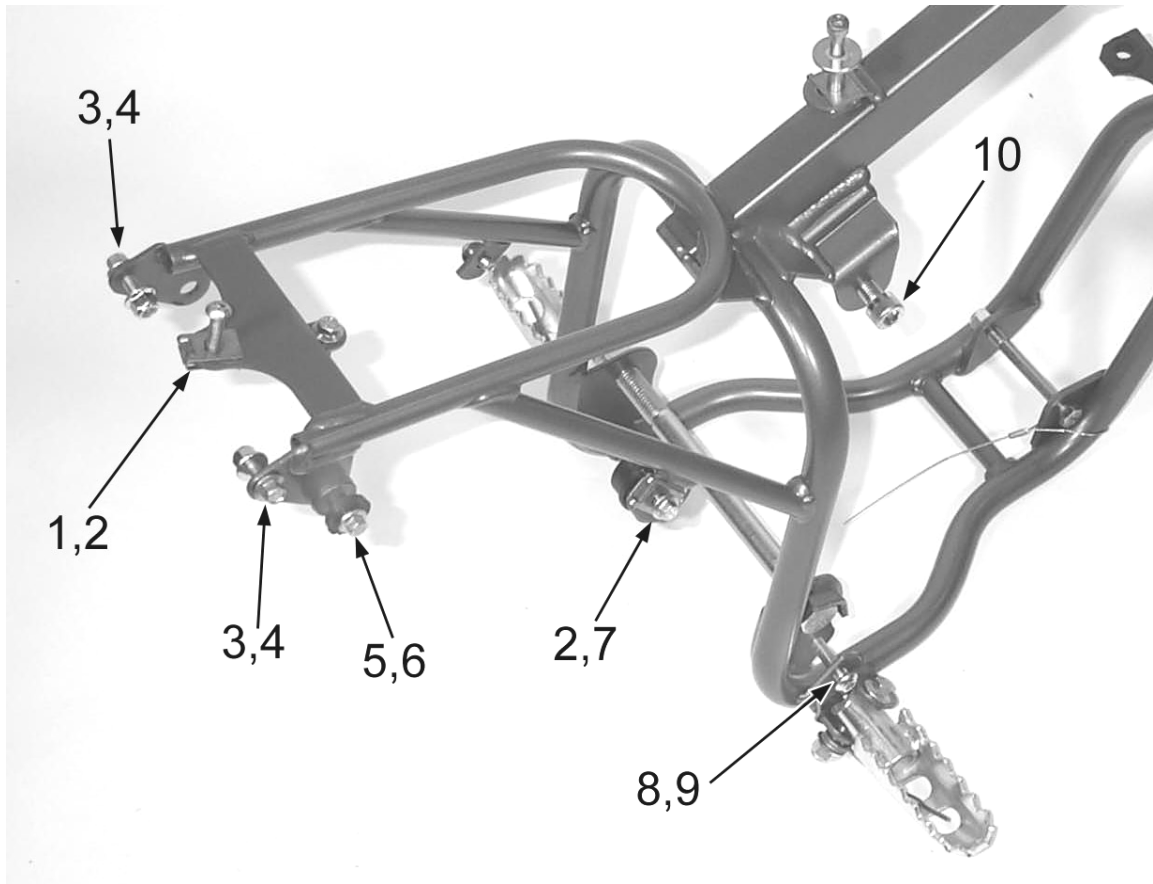

Figure 20

Frame – Seat, Fender, Right Side Panel, Brake Pedal, Silencer & Shock Mounts		
REF #	PART #	DESCRIPTION
	FAMU0004	FRAME 2004 CM50
1	HCBB0635	M6X35 BUTTON HEAD CAP SCREW
2	HCHA0003	6MM CLIPNUT
3	HCBF0620	M6X20 FLANGE HEAD BOLT
4	HCNF0602	6MM NYLOC FLANGE NUT
5	HCBF0630	M6X30 FLANGE HEAD BOLT
6	MCMUGR04	GROMMET – SILENCER (2 REQ'D)
7	HCBF0616	M6X16 FLANGE HEAD BOLT
8	HCBB0803	M8X40 BUTTON HEAD SCREW
9	HCNL0801	8MM LOCK NUT
10	HCBC1001	M10X45 SOCKET HEAD CAP SCREW

Parts - Frame – Mounting Hardware III

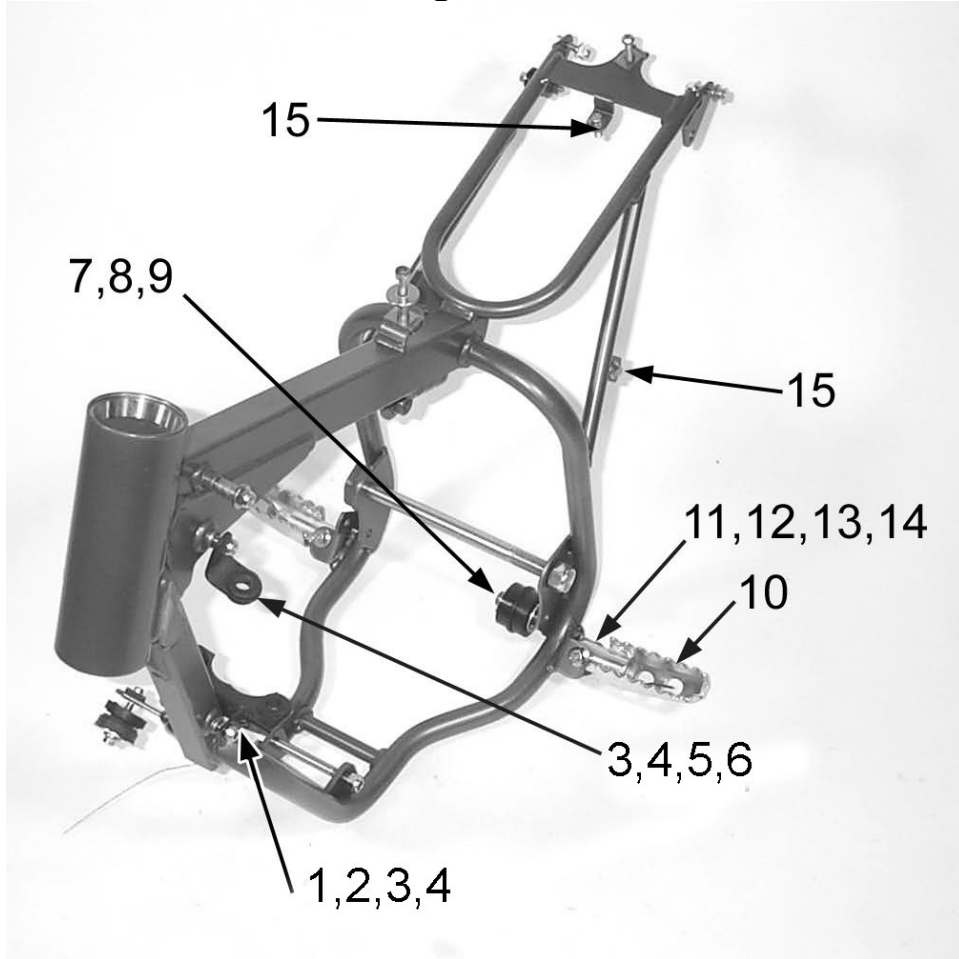

Figure 21

Frame – Radiator, Footpeg, Chain Roller, and Airbox Mounts		
REF #	PART #	DESCRIPTION
	FAMU0004	FRAME 2004 CM50
1	ECHA0003	MOUNTING BRACKET – RADIATOR BOTTOM
2	HCBC0607	M6X50 SOCKET HEAD CAP SCREW
3	HCNL0601	6MM LOCK NUT
4	MCKGGR00	GROMMET – RADIATOR MOUNT (2 REQ'D ON BOTTOM, 1 ON TOP BRACKET)
5	ECHA0109	MOUNTING BRACKET – RADIATOR TOP
6	HCBC0660	M6X60 SOCKET HEAD CAP SCREW
7	FCMU0057	CHAIN ROLLER
8	HCWF1201	WASHER FLAT, CHAIN ROLLER (2 REQ'D)
9	HCCP0002	COTTERPIN 3/32 X 1 (2 REQ'D)
10	TCMU0014	FOOTPEGS (SET OF 2)
11	TCMU0102	SPRINGS – FOOTPEG (SET OF 2)
12	HCBF0850	M8X50 FLANGE HEAD BOLT
13	HCWF5601	FLAT WASHER
14	HCNL0801	8MM LOCK NUT
15	HCBF0616	M6X16 FLANGE HEAD BOLT

Parts – Front Brakes

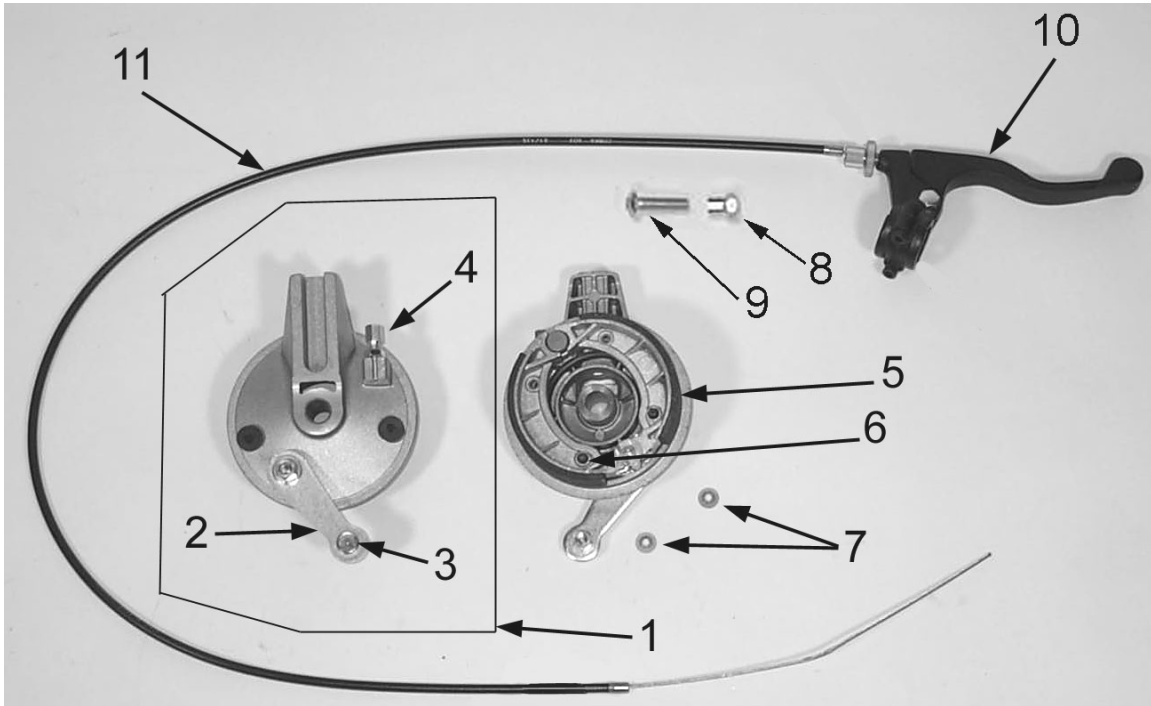

Figure 22

Front Brakes		
REF #	PART #	DESCRIPTION
1	BCMU0300	BRAKE HUB – FRONT
2	BCMU0113	BRAKE ARM – FRONT
3	BCMU0005	CABLE CLAMP, WASHER & NUT
4	BCMU0006	CABLE ADJUSTOR
5	BCMU0110	BRAKE SHOE (PAIR)
6	BCMU0010	SPRING – BRAKE RETURN
7	BCMU0011	PUSH NUT – BRAKE SPRING (2 REQ'D)
8	BCMU0007	BRAKE STOP
9	HCBH0808	M8X30 BUTTON HEAD SCREW
10	BCMU0100	BRAKE LEVER / PERCH ASSEMBLY WITH ADJUSTER
11	BCMU0108	BRAKE CABLE

Parts – Front Wheel

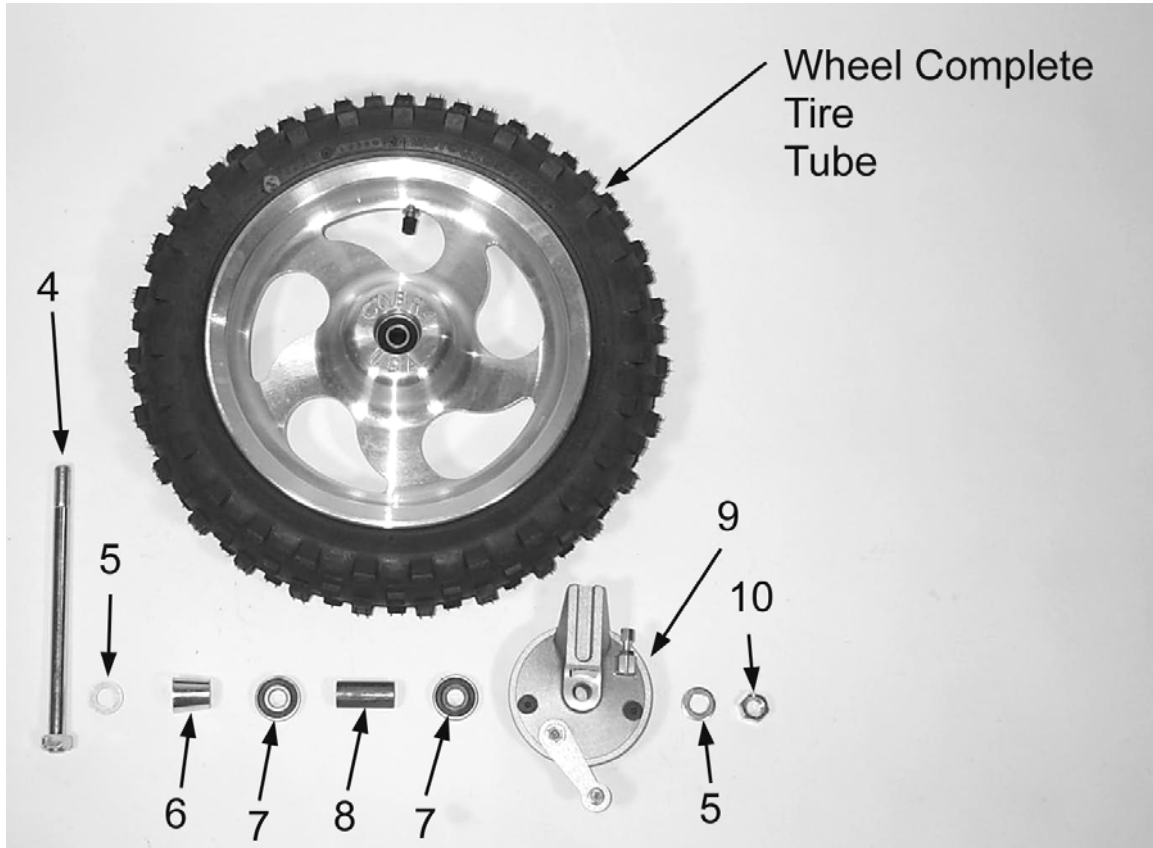

Figure 23

Front Wheel		
REF #	PART #	DESCRIPTION
1	WAMU0300	FRONT WHEEL COMPLETE
2	WCMU0250	FRONT TIRE 10X2.50"
3	WCMUTU10	TUBE 10"
4	WCMU0014	FRONT AXLE
5	HCWF1202	WASHER – AXLE
6	WCMU0023	FRONT WHEEL SPACER
7	WCMU0020	BEARING – WHEEL (2 REQ'D)
8	WCMU0004	SPACER – WHEEL FRONT
9	BCMU0300	BRAKE HUB – FRONT
10	HCNS1201	NUT - AXLE

Parts – Plastic Bodywork & Seat

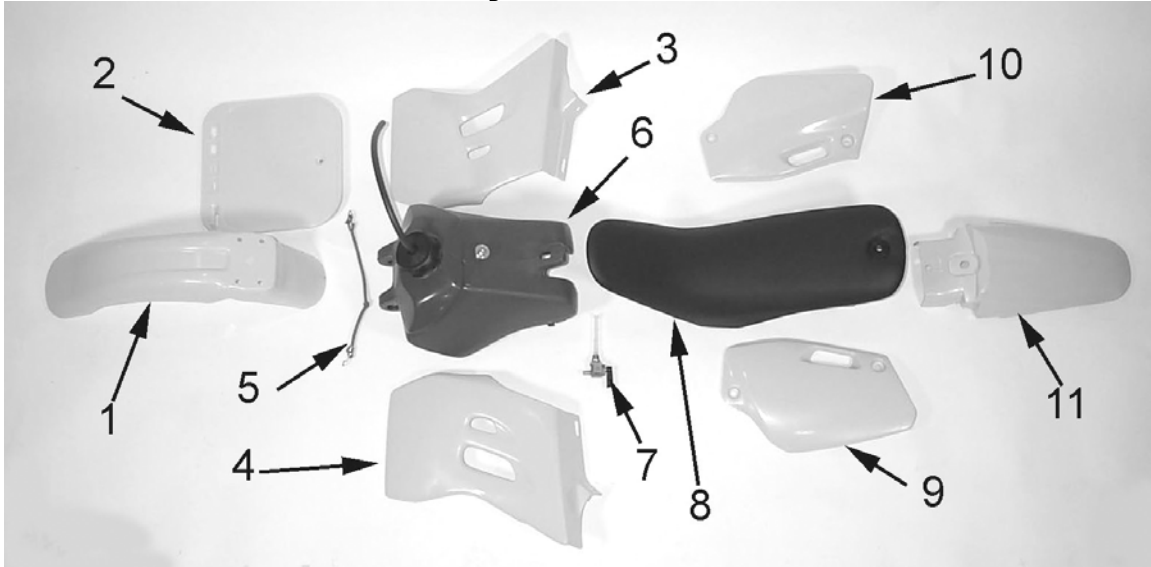

Figure 24

Plastic and Seat		
REF #	PART #	DESCRIPTION
NOT SHOWN	TCMU0020	GRAPHIC KIT
1	TCHA0107	FRONT FENDER
NOT SHOWN	HCBF0616	FENDER BOLT, M6X16 FLANGE HEAD (4 REQD)
2	TCMU0005	NUMBER PLATE - FRONT
NOT SHOWN	HCBF0625	M6X25 FLANGE HEAD BOLT – FRONT NUMBER PLATE MOUNT
3	TCHA0008	RADIATOR SHROUD - RIGHT
4	TCHA0009	RADIATOR SHROUD - LEFT
5	MCMUBC01	BUNGEE CORD – SHROUD HOLDING
6	TCHA0001	FUEL TANK – NOT COMPLETE
NOT SHOWN	TCHA0002	CAP – FUEL TANK
NOT SHOWN	TCHA0003	HOSE – FUEL CAP
NOT SHOWN	HCSF0620	M6X20 PHILIPS HEAD SCREW – SEAT & SHROUD HOLD
NOT SHOWN	TCHA0005	SPACER – SEAT & SHROUD HOLD
NOT SHOWN	TCHA0006	SPACER – FRONT TANK MOUNT (2 REQ'D)
NOT SHOWN	HCBC0685	M6X85 SHCS – FRONT TANK MOUNT
NOT SHOWN	HCNL0601	6MM LOCK NUT – FRONT TANK MOUNT BOLT
NOT SHOWN	HCBC0645	M6X45 SOCKET HEAD CAP SCREW
NOT SHOWN	TCHA0004	BUSHING – REAR TANK MOUNTING
7	TCMU0038	FUEL PETCOCK
8	TCCM0007	SEAT
NOT SHOWN	HCBB0635	M6X35 BUTTON HEAD CAP SCREW – SEAT HOLDING
9	TCHA0011	NUMBER PLATE – LEFT REAR
NOT SHOWN	HCBF0616	M6X16 FLANGE HEAD BOLT – FRONT SECURE
NOT SHOWN	HCBF0620	M6X20 FLANGE HEAD BOLT – FENDER & REAR SECURE
NOT SHOWN	HCFN0602	6MM NYLOC FLANGE NUT
10	TCHA0010	NUMBER PLATE – RIGHT REAR
NOT SHOWN	HCBF0616	M6X16 FLANGE HEAD BOLT – FRONT SECURE
NOT SHOWN	HCBF0620	M6X20 FLANGE HEAD BOLT – FENDER & REAR SECURE
NOT SHOWN	HCFN0602	6MM NYLOC FLANGE NUT
11	TCHA0112	FENDER – REAR
NOT SHOWN	HCBF0616	M6X16 FLANGE HEAD BOLT – FENDER & AIRBOX SECURE

Parts – Rear Brake

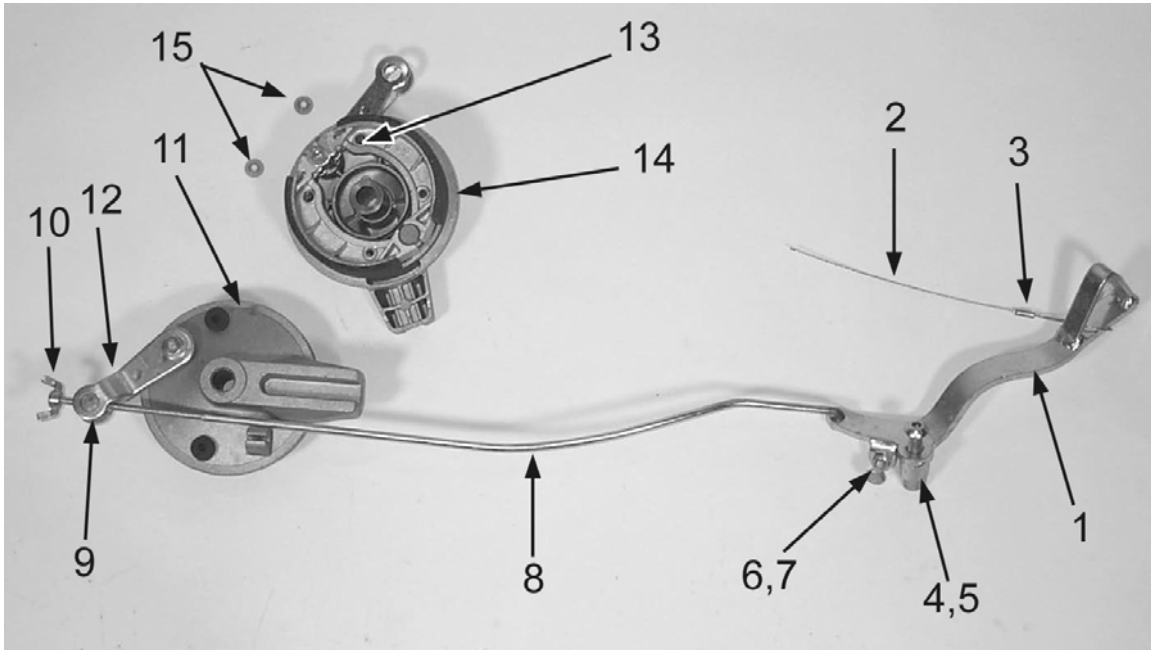

Figure 25

Rear Brake System		
REF #	PART #	DESCRIPTION
1	BAMU0000	BRAKE PEDAL
2	BCMU0008	CABLE – BRAKE SNAKE
3	BCMU0009	CRIMP – BRAKE SNAKE
4	HCBB0803	M8X40 BUTTON HEAD SCREW
5	HCNL0801	8MM LOCK NUT
6	HCBH0602	M6X25 HEX HEAD BOLT (BRAKE STOP ADJUST)
7	HCNS0601	6MM NUT
8	BCCM0105	BRAKE ROD
9	BCMU0111	BRAKE ROD BARREL
10	HCNW0001	BRAKEROD WINGNUT
11	BCMU0109	BRAKE HUB - REAR
12	BCMU0112	BRAKE ARM – REAR
13	BCMU0010	SPRING – BRAKE RETURN
14	BCMU0110	BRAKE SHOE (PAIR)
15	BCMU0011	PUSH NUT – BRAKE SECURE (2 REQ'D)
16	HCCP0001	COTTER PIN - 3/32 X 1/2
17	HCWF0502	5MM FLAT WASHER

Parts – Rear Wheel

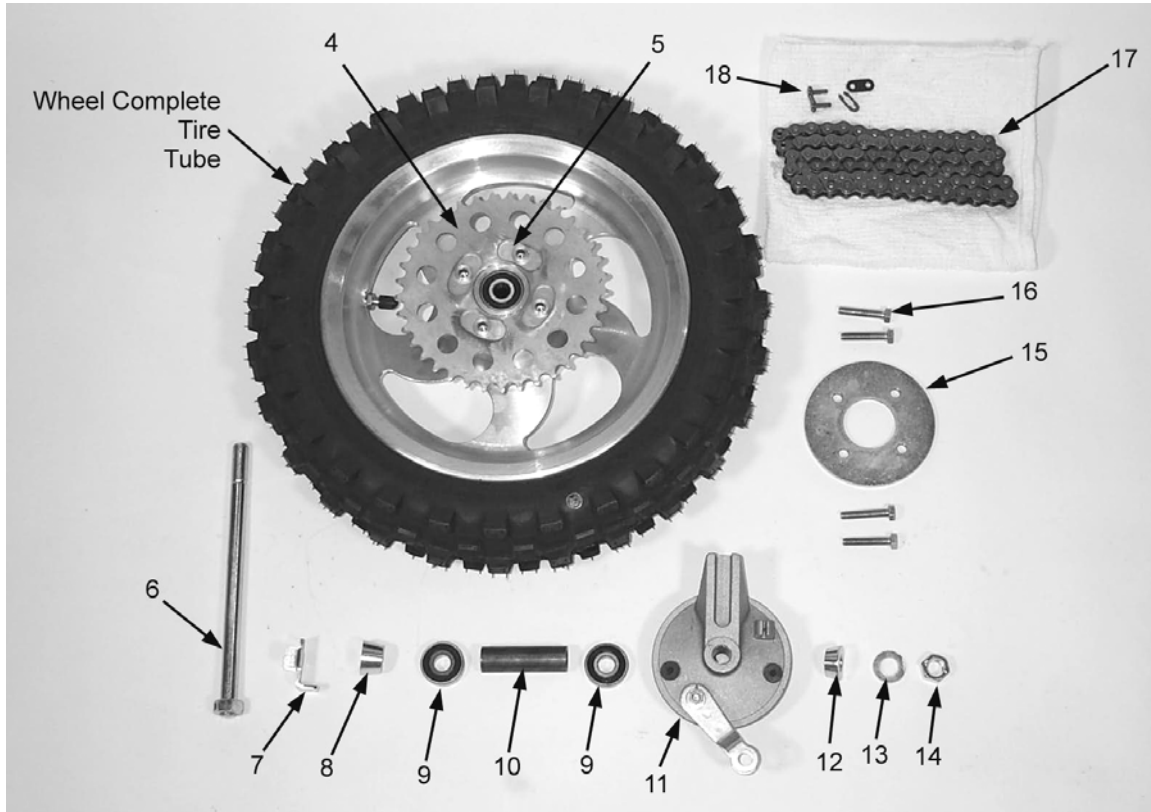

Figure 26

Rear Wheel		
REF #	PART #	DESCRIPTION
1	WACM0100	WHEEL COMPLETE – REAR
2	WCMU0275	TIRE – REAR 10X2.75"
3	WCMUTU10	TUBE – 10"
4	PCMU0137	SPROCKET – 37T
5	PCMU0059	RUBBER SPROCKET DAMPERS
NOT SHOWN	WCMU0006	SPACER – SPROCKET DAMPER
6	WCMU0016	REAR AXLE
7	HCPA0002	AXLE HEAD FIXING PLATE
8	WCMU0001	REAR WHEEL SPACER (SPROCKET SIDE)
9	WCMU0020	WHEEL BEARING (2 REQ'D)
10	WCMU0003	WHEEL BEARING SPACER - REAR
11	BCMU0109	BRAKE HUB - REAR
12	WCMU0009	REAR WHEEL SPACER (BRAKE SIDE)
13	HCWF1202	WASHER – AXLE
14	HCNS1201	NUT – AXLE
15	WCMU0008	WHEEL DAMPER PLATE
16	HCBH0701	M7X35 HEX HEAD BOLT
17	PCCM0001	CHAIN –88 LINKES 420
18	PCMU0001	MASTER LINK – 420 CHAIN

Parts – Shock

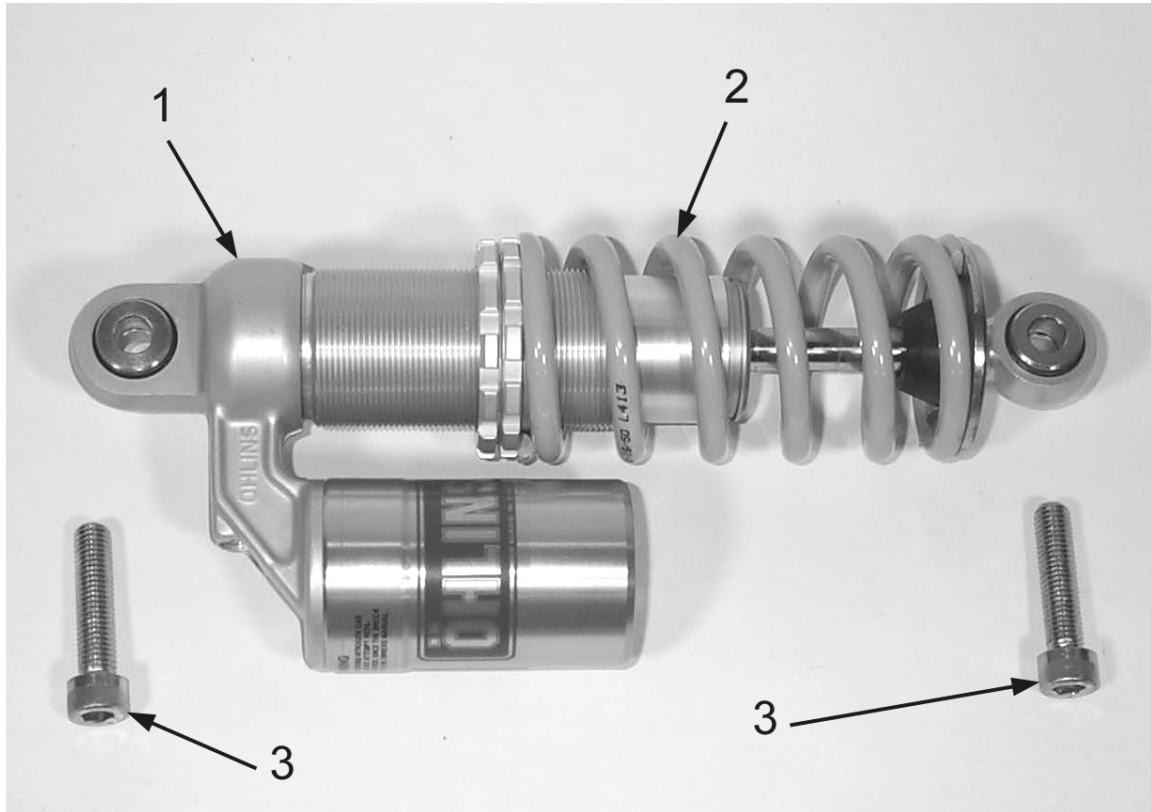

Figure 27

REAR SHOCK		
REF#	PART #	DESCRIPTION
1	SACM2004	SHOCK ABSORBER
2	SCMUOH05	SPRING – STANDARD (285 lb/in)
	SCMUOH04	SPRING – LIGHT (275 lb/in)
	SCMUOH06	SPRING – HEAVY (295 lb/in)
3	HCBC1001	M10X45 SHCS

Parts – Swingarm Assembly

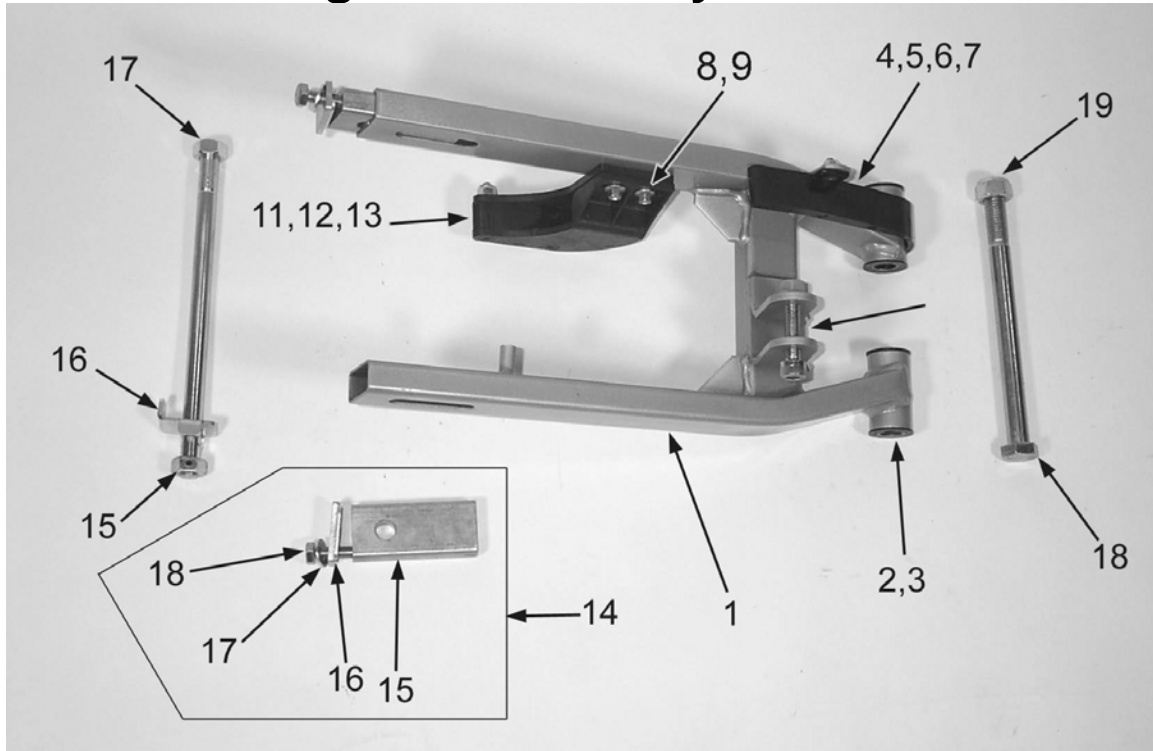

Figure 28

Swingarm		
REF #	PART #	DESCRIPTION
	GACM2004	SWINGARM ASSEMBLY (CONTAINS ITEMS 1 - 13)
1	GAMU0004	SWINGARM
2	GCMU0001	SWINGARM BUSHING (SINGLE PIECE)
3	GCMU0009	SPACER - PIVOT TUBE
4	GCMU0017	CHAIN GUARD
5	HCFH0516	M5X16 FLAT HEAD SCREW
6	HCWF0501	5MM FLAT WASHER
7	HCNL0501	5MM LOCK NUT
8	HCBF0620	M6X20 FLANGE HEAD BOLT (2 REQ'D)
9	PAKG0001	CHAIN GUIDE – ASSEMBLY COMPLETE
11	PCKG0004	CHAIN GUIDE - BOTTOM SLIDER
12	HCBFT640	6X40 FLAT HEAD SCREW (2 REQ'D)
13	HCNL0601	6MM LOCKNUT (2 REQ'D)
14	FAMU0005	WHEEL PULL ASSEMBLY
15	FCMU0203	WHEEL PULL
16	FCMU0202	WHEEL PULL ENDCAP
17	HCWF5601	5/16" FLAT WASHER
18	HCBF0810	M8X65 HEX HEAD BOLT (FULL THREAD)
19	HCBH1403	SWINGARM PIVOT BOLT
20	HCNL1402	14MM LOCK NUT
21	HCBC1001	M10X45 SOCKET HEAD CAP SCREW

Service

Trained technicians with precision gauging and proper assembly fixtures carefully assemble all Cobra engines to specific clearances. If you feel you have the skills, and the appropriate tools, to perform the following service tasks please follow the instructions closely. The part numbers are listed throughout to help you when ordering parts from your local Cobra dealer.

If you don't feel comfortable with the service work, log on to www.cobramotorcycle.com to find a Cobra dealer or Call 517 437 9100.

Engine Service

One method for determining whether the top end of your engine needs rebuilt is to perform a WOT (Wide Open Throttle) kicking compression test. Before performing the procedure please read the caution notes below.

CAUTION:

- There appears to be a wide range of variability in reading compression gauges across the country.
- The head volume of this Cobra Motorcycle is very small and so requires many kicks ~20 before you establish the most accurate reading possible.
- Because of the geometry of the spark plug used in this Cobra Motorcycle, the adapter used with your compression tester must have a similar volume protruding into the combustion chamber to establish an accurate value.
- Length of hose on the compression tester will affect the reading. The shorter the hose length the more accurate your reading will be.

Because of these difficulties in measuring an *absolute* compression value, a useful *relative* value can be achieved by testing your bike's compression with your own particular gauge after a new top end or when the bike is new so that you know what your particular gauge reads on a 'fresh' engine. When it has dropped to 90% of its original value the engine will be down on power and would benefit from a rebuild. When it's dropped to 80% it really needs rebuilt! Using the table below will help you determine monitor the condition of your top end.

	Engine is Fresh Measured Value	Engine Down on Power Measured Value * 0.9	Engine NEEDS Rebuilt Measured Value * 0.8
Example	110 psi	110 psi * 0.9 = 99 psi	110 psi * 0.8 = 88 psi
Your Values			

Procedure for Compression Testing

1. Shut off the fuel petcock.
2. Install the compression gauge into the spark plug hole.
3. Hold the throttle to wide open, and kick repeatedly (approximately 20 times) or until the gauge reading does not increase in value with each kick.

Engine Removal

To service the bottom end and transmission, the engine must be removed from the frame.

Tools required

- 5/16", 10, 14, mm socket
- 10, 13, 22 mm wrench
- 10, 17 & 19 mm sockets
- 9/64", 3,4 & 5 mm hex key (Allen wrench)
- 7 mm nut driver, flat or Phillip, screwdriver for hose clamps
- Spring remover
- Flywheel / clutch puller (#MCMUTL68)
- Clutch nut removal tool (Call local dealer for details).

Procedure

1. Remove the seat (4mm hex key).
2. Turn of the fuel at the petcock and disconnect the fuel line.
3. Remove the tank (5 mm hex key & 10 mm socket).
4. Remove the carburetor from the inlet (flat head or Phillips head screwdriver, 7 mm nut driver).
5. Remove the right side number plate (3mm hex key).
6. Remove the silencer & pipe (spring remover, 5mm hex, & 10mm wrench).
7. Disconnect the ground wire from the reed cage with a 5 mm hex key (depending on your ultimate repair, you may want to reinstall the fastener in the inlet).
8. Leaving the coolant lines connected to the engine, remove the radiator from the frame (5mm hex with 10 mm wrench).
9. Remove the master link from the chain.
10. Remove front engine mount bolt (13 mm socket, 6 mm hex key).
11. To access the swingarm bolt, remove brake lever (13 mm wrench, 5 mm hex key).
12. Remove the swingarm bolt (22mm socket & wrench).

NOTE:

Only drive the swingarm bolt far enough to clear the engine, leave it holding the one side of the swingarm to the frame

13. Remove the engine from the right side of the frame.

14. Locate a suitable container for the engine coolant and remove radiator hoses from engine (coolant will drain).

NOTE:

If the coolant looks to be free of contaminants it may be reused.

NOTE:

If you are merely performing a top end service skip ahead to *Top End Disassembly Procedure*.

Complete Engine Disassembly Procedure

1. Remove the magneto cover (9/64" hex key)
2. Remove the bolt from the water pump shaft (4mm) and slide off the belt cover and the water pump belt
3. Using a flywheel holding tool and 14 mm socket remove the nut that secures the flywheel.
4. Using the Cobra flywheel / clutch puller (#MCMUTL68), remove the flywheel from the crankshaft.
5. Remove the stator (9/64" hex key).
6. Remove the nut holding the large gear to the transmission input shaft (19 mm socket).
7. Remove the special nut / starter gear that holds on the clutch (special tool available, contact your local dealer).
8. With the Cobra flywheel / clutch puller (#MCMUTL68), remove the clutch from the crankshaft (details in Clutch Service portion of this manual).

Top End Disassembly Procedure

1. Remove the cylinder head nuts (5/16").
2. Remove the outer cylinder head.
3. Remove the inner cylinder head.

INSPECTION NOTE:

Inspect the cylinder head for deposits and abrasions.

1. If there are deposits they should be removed
 - a. Black oily deposits (indicating a rich mixture or improper oil type/quantity) can be removed with solvent
 - b. Crusty deposits (indicating dirt ingestion) can be removed with solvent and may require some scraping.
2. Abrasions
 - a. Pitting or erosion indicates detonation and may require cylinder head replacement, also
 - i. Retard the ignition timing
 - ii. Use a higher octane fuel
 - b. Missing chunks or indentations indicate broken hardware or ingested items - replace the cylinder head.

4. Remove the cylinder.

INSPECTION NOTE:

Inspect the cylinder bore for abrasions, deposits, and missing coating.

1. If abrasions: scrapes, scratches, pitting, etc... are found, replace the cylinder.
2. If deposits are all are found
 - a. Clean with muratic acid.
 - b. Once the deposits are removed, inspect for abrasions and missing surface coating.
 - i. If there are abrasions or missing coating, replace.
 - ii. If all looks well, the cylinder may be saved.

 WARNING

Muratic acid can be dangerous. Follow the manufacturers instructions closely.

5. Remove the piston clip with a scribe.
6. Remove the piston pin with a piston pin remover.

INSPECTION NOTE:

Inspect the piston for abrasions and deposits on the top and sides and clean or replace as necessary.

Splitting the Cases

1. Remove the fasteners holding the two halves of the crankcase together.
2. Separate the cases with a proper case splitting tool.

CAUTION:

Take caution when handling the crankshaft. It is the main power transfer to the rest of the engine. If it is out of alignment, it will cause premature failure of your bearings which can lead to serious damage to the cylinder and the rest of the engine. Do not try to true the crank yourself. Truing the crank should be done professionally.

CAUTION:

- If you split the cases, check the gear tooth faces for chapping & signs of fatigue.
- Check the small needle bearings for fatigue. If the bearings are damaged, the engine cases should be checked to make sure the needle-bearing casing didn't oblong the bearing hole in the case.
- Needle bearings should be replaced every racing season.

Engine assembly

CAUTION:

For any seals that are to be installed, apply a light amount of grease to the seals' ID, assembly lube on all bearings and a small amount of Loctite to the OD.

1. Press the three bearings into the respective holes in each case half.
2. Press in the crank seals such that the concave side faces the crank weights.
3. Press in the counter shaft seal (concave side faces inside of transmission)
4. Install the water pump assembly wire ring retainer
5. Press in the water pump assembly
6. Tap both ways axially then verify easy rotation.
7. Inspect the crankshaft for proper true geometry (no more than 0.002 ", 0.05mm, measured at bearing journal area while supported from the ends).
8. Press crank into right case half

CAUTION:

Insert a 7.05mm (0.278") shim between the crank throws before pressing on the crank.

9. Insert the transmission input shaft and install large drive gear as shown in figures 25 & 26.

NOTE:

If the nut was removed from the input shaft, it will be easier to install and tighten later.

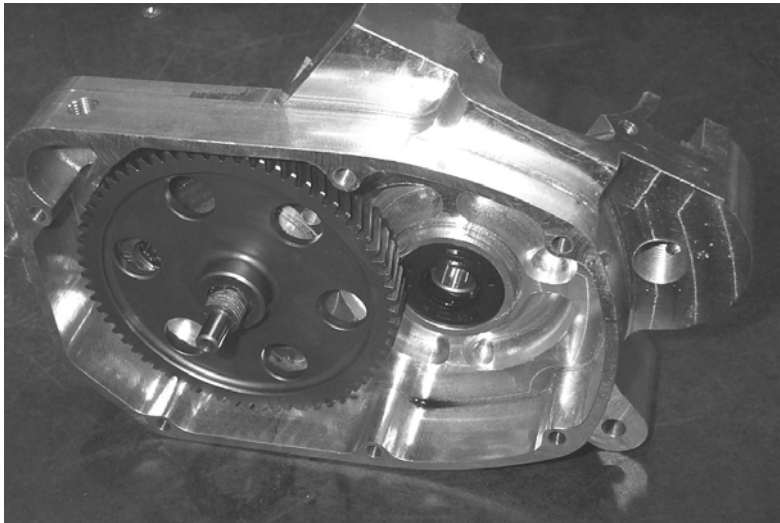

Figure 25

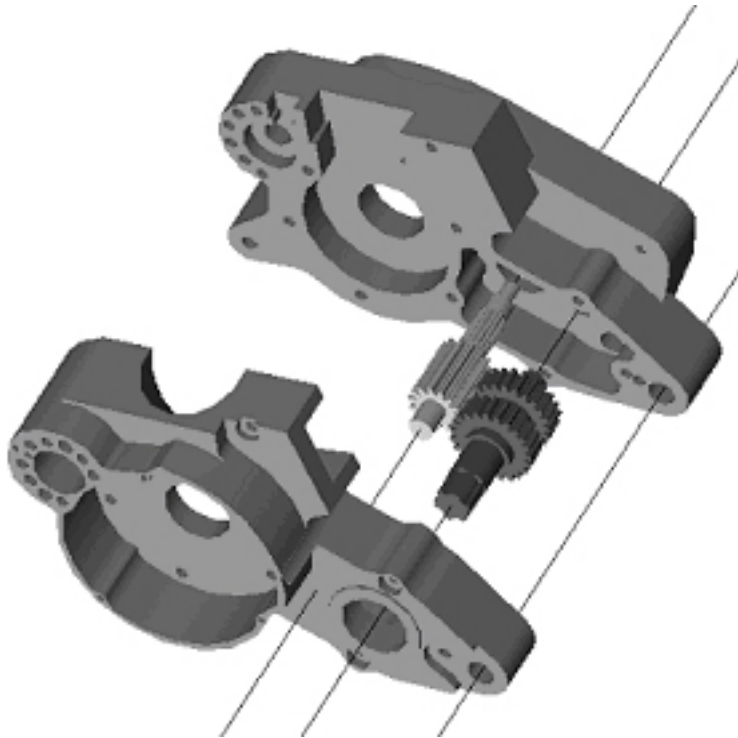

Figure 26

10. Insert dowel pins in the left side case as shown in figure 27.

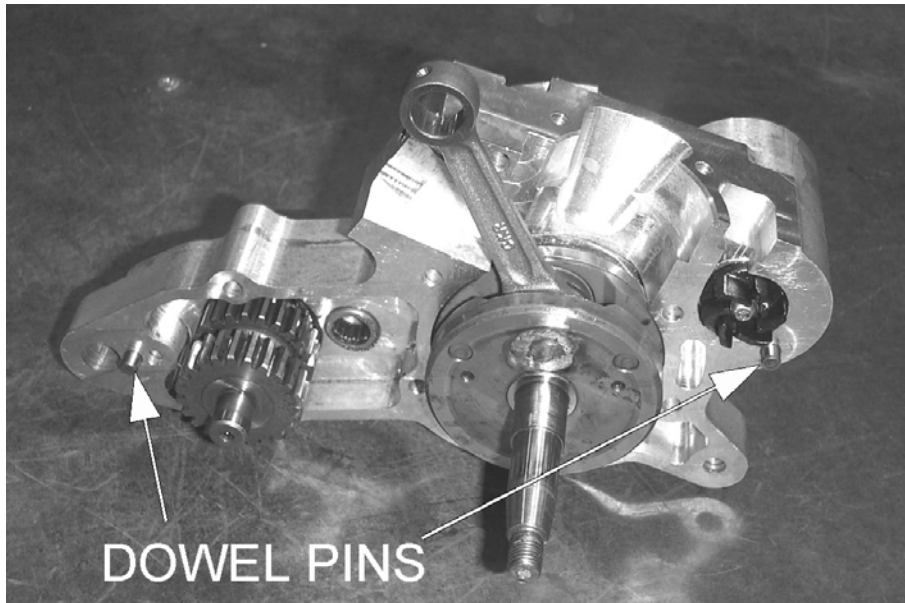

Figure 8

11. Clean the gasket mating surfaces with acetone

12. Apply gasket sealer (ThreeBond 1104 gasket material or equivalent) to the mating surfaces of both crankcase halves).

NOTE: Gasket material is only required around the crankcase, and not the transmission.

13. Apply the crankcase gasket to the left crank case half being sure to install the gasket behind the connecting rod.

14. Assemble the two case halves together with the shim installed between the crank throws. **Be sure to remove the shim after assembly.**

15. Insert the screws with the proper lengths at locations shown.

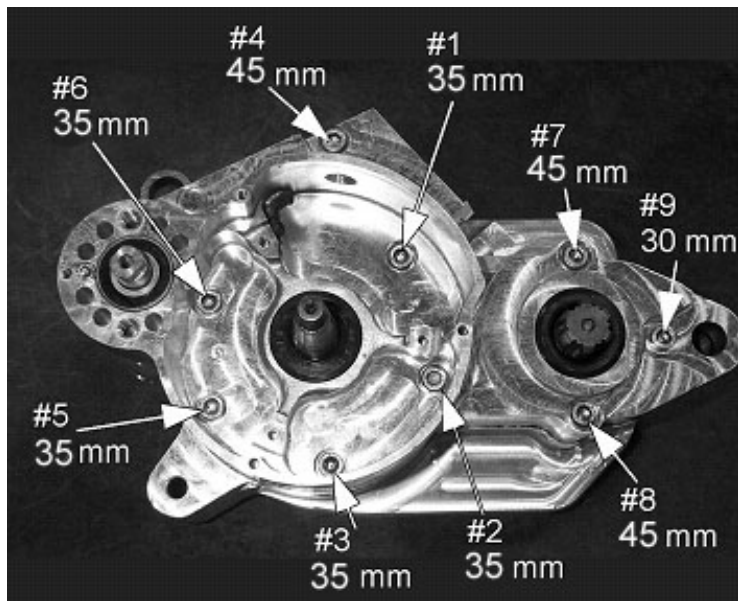

Figure 28

16. Torque to 12 Nm (105 in-lb) in the pattern shown in figure 28.
17. Trim away any excess gasket material.

NOTE: Check engine mount holes for excess material that may cause problems in engine installation.

18. Install the piston with new wrist pin bearing and, pin and clips.

CAUTION:

Be sure to align the piston such that the arrow on the top piston surface points to the exhaust (front of bike/engine) and put assembly lube on the connecting rod bearing.

19. Install the piston rings.

CAUTION:

Ring end gap should be no less than 0.25 mm (0.010") and no more than 0.64mm (0.025")

20. Apply gasket sealer (ThreeBond #1104, semi-drying liquid gasket material) to the cylinder deck areas around the coolant passage and cylinder studs as shown in figure 29.

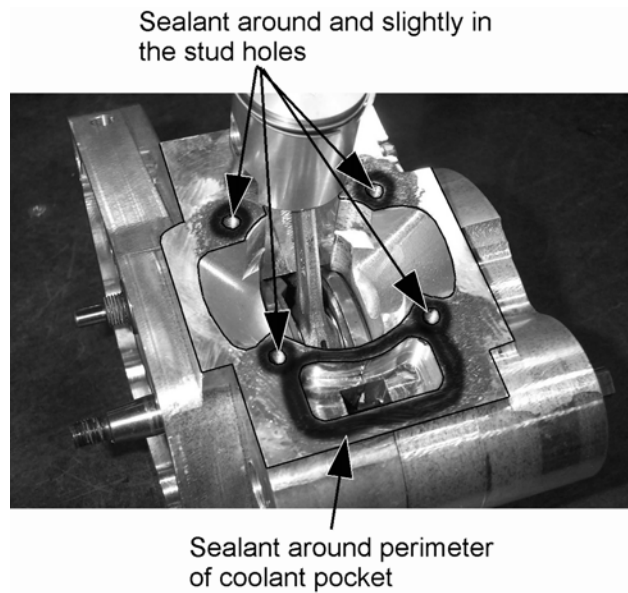

Figure 29

21. Install the base gasket.
22. Apply gasket sealer to the top surface of the gasket in the same locations indicated in figure 29.
23. Install the cylinder being sure that the piston rings are properly aligned with the indexing pins.

CAUTION:

Never force the cylinder. If resistance is felt, determine the problem and solve it. Once installed slightly rotate the cylinder back and forth insuring that the rings are properly seated.

24. Install the cylinder studs and o'rings as shown in figure 30.

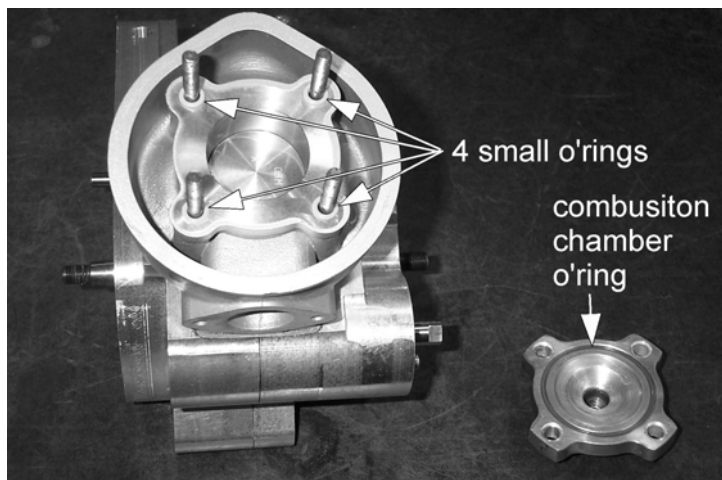

Figure 30

25. Install cylinder head insert.

NOTE: A light application of silicone grease can help hold the o'rings into position during assembly.

26. Pressure test the engine insuring an acceptable leakdown rate.
27. Install O'rings as shown in figure 31.

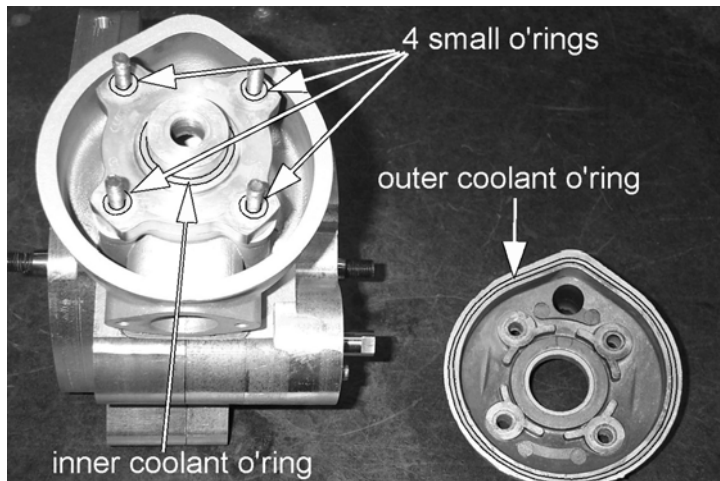

Figure 31

28. Install the cylinder head.
29. Install the washers (with flat side down) and nuts. Torque to 105 in-lb (12 Nm)
30. Secure the ground strap to the back left cylinder stud with an additional nut.
31. Install reed and inlet manifold with new gaskets (105 in-lb, 12 Nm) applying 1104 gasket sealer to both sides of all gaskets.
32. Leak check the engine to 20 psi to ensure proper seal.
33. Install stator reinstalling the grommet and wires (snug the bolts).
34. Install the rotor per *Rotor Installation* section, under the *S3: Ignition* portion of this manual.
35. Install the water pump outlet pipe (apply Ultra black Hi-Temp RTV silicon gasket maker to the threads before assembly) before installing the clutch and rotate to a vertical position with the engine resting on a bench
36. Install the clutch per *Clutch Installation* section in this manual.
37. Install the coolant drain plug with copper washer (11 ft-lb, 15 Nm).
38. Make sure that the exhaust spacer is on the cylinder (53 in-lb, 6 Nm).
39. Install the spark plug with a fresh gasket (to apply the proper torque to the spark plug when inserting, one must first screw the spark plug in until the metal gasket ring causes resistance and then turn another 1/8 to 1/4 turn).

Clutch

Cobra clutch puller assembly:

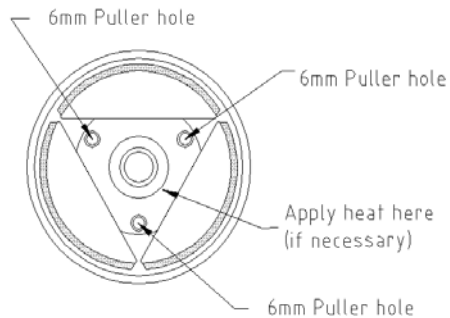

Figure 36

Clutch puller diagram

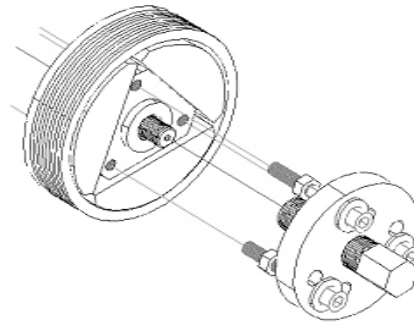

Figure 37

Tools recommended for clutch service:

- Universal clutch puller- a universal puller that pulls the clutch, main drive gear and rotor. (Part # MCMUTL70).
- 5mm T-handle
- Clutch nut removal tool (ECMU0078) & spanner wrench (ECMU0082).
- *Cobra 3 Shoe Clutch Milk* (Part # MCMUGF01) or Dexron III ATF.

CLUTCH REMOVAL:

1. Drain the engine transmission oil.
2. Remove the pipe and remove the 6 bolts that hold the kick-starter cover on.
3. Remove the clutch nut (not left hand thread) on the end of the crankshaft with the clutch nut removal tool.
4. Attach the *COBRA CLUTCH PULLER*. There are three 6mm clutch puller holes located on the ends of the center hub. (figures 32 & 33) You must use a *draw type puller* to remove the clutch.

CAUTION:

Do not use a jaw type puller or use the 6mm tapped holes as jackscrews or you are likely damage the clutch or drum.

5. If necessary apply heat to the center clutch hub.

CAUTION:

Do not heat the crankshaft threads or the aluminum shoes.

6. Keep tension on the puller as you are heating it.

 WARNING

The clutch will often pop off under tension from the puller and it will be very hot.

CLUTCH WASHER STACKUPS:

Once the clutch is removed, and cool to touch, carefully put it into a vice and remove the center shoulder bolt out of each clutch shoe. You will probably have to heat the center hub again to remove the bolts. Once you get a bolt loosened, carefully remove it with the shoe and observe the way the spring washers are stacked.

CAUTION:

It is very important that the clutch stack be reassembled as it was disassembled unless new shoes are being installed then it is important to reinstall per figure 34.

CLUTCH ASSEMBLY REFERENCE DRAWING		
REF #	PART #	DESCRIPTION
1	CAKG0004	Set of three shoes, springs, bolts, flat washers & nuts
2	CAMU0008	Set Of three springs, washers, bolts & nuts
3	CAKG0005	Set of three shoes
4	HCBS5603	Single center shoulder bolt

CAUTION:

The '4 stack' clutch spring stack is new for 2004.

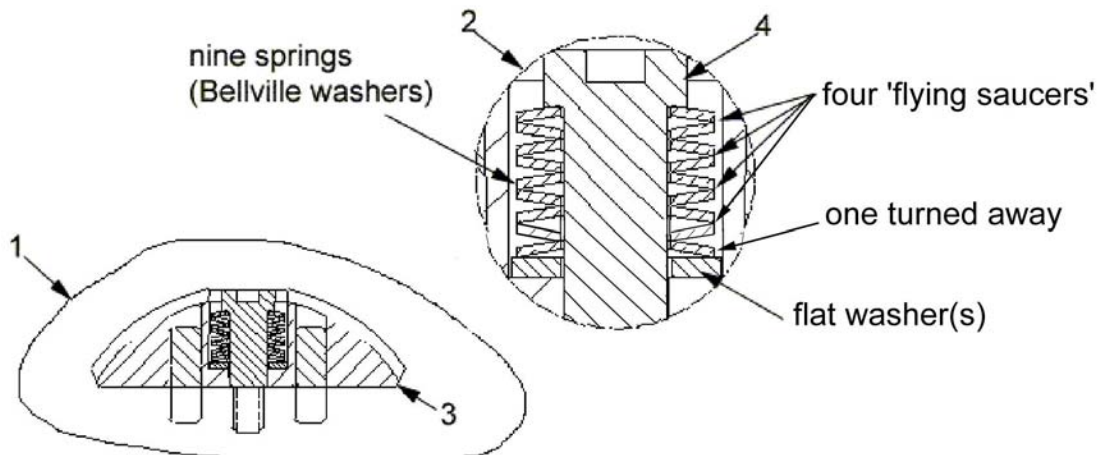
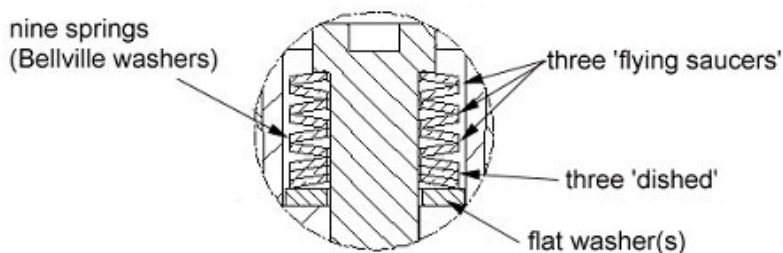

Figure 34 Recommended clutch spring stack. Each 'spring' stack contains nine springs (Bellville washers) - six arranged into four 'flying saucers', and one turned away against the flat washer(s). An optional 'three stack' will deliver smoother, less aggressive power. For details see Figure 34b.



Optional 'three' stack for smoother, less aggressive power delivery

Figure 34b

Clutch adjustment washers

Your Cobra comes stock with a single flat washer at the bottom of the spring washer stack. The thickness of that flat washer is 0.056" (1.4mm). Cobra offers several thicknesses of thin adjustment washers that allow clutch engagement tuning. Increasing the flat washer(s) thickness increases the engine speed for clutch engagement thus increasing the abruptness of clutch engagement (harder hit). Conversely, decreasing the flat washer(s) thickness decreases the engine speed for clutch engagement thus decreasing the abruptness of clutch engagement (softer hit).

Part #	Thickness mm (inch)
HCWS0801	1.4 (0.056)
HCWS0802	1.2 (0.047)
HCWS0803	0.79 (0.031)
HCWS0804	0.64 (0.025)
HCWS0805	0.51 (0.020)
HCWS0806	0.38 (0.015)

Use the table above to order adjustment washers. Replace the stock washer with the proper combination of adjustment washers that delivers the desired clutch hit.

Hit	Thickness (mm)	Thickness (inch)
Softer	1.17 (0.79 + 0.38)	0.046 (0.031 + 0.015)
	1.30 (0.79 + 0.51)	0.051 (0.031 + 0.020)
Stock	1.4	0.056
	1.58 (1.2 + 0.38)	0.062 (0.047 + 0.015)
	1.71 (1.2 + 0.51)	0.067 (0.047 + 0.020)
	1.84 (1.2 + 0.64)	0.072 (0.047 + 0.025)
Harder	1.99 (1.2 + 0.79)	0.078 (0.047 + 0.031)

CAUTION:

It is easy to prematurely damage the clutch and other engine components with improper clutch adjustment. If you are unsure of how to adjust the clutch, by even the slightest, contact the Cobra Technical Support Group before making adjustments.

Clutch shoe wear:

- If the clutch has been slipping and shows signs of glazing, it is best to replace the shoes. We have found that once the shoes are glazed, even if deglazed with emery paper or a file, the performance is reduced.
- The best way to prevent glazing is by not gearing too high, changing the oil as specified and by not blipping the throttle. Every time you blip the throttle, you are working your clutch springs.

CAUTION:

The clutch produces a tremendous amount of heat and when a rider is blipping the throttle. This makes the clutch and clutch springs wear out quicker. This also

makes your engine tend to run hotter which decreases engine power and degrades ignition stator efficiency. It is important to train your rider **NOT** to be a throttle 'blipper'.

CAUTION:

Sludge build-up between the spring washers also keeps the clutch shoe from engaging fully and this will cause the clutch to start to slip. So you will need to clean the sludge out or just replace the spring washers and bolts with new ones. How quickly this sludge builds up depends on how often you **change your oil** and whether your rider is a throttle 'blipper'.

REF #	PART NO.	DESCRIPTION
1	ECMU0017	Crank seal
2	ECMU0040	Clutch to hub spacer
3	ECMU0003	Brass bushing
4	ECMU0033	Clutch Hub w/ brass bushing
5	CAKG0002	Clutch Complete w/ Arbor
6	ECMU0018	Clutch nut

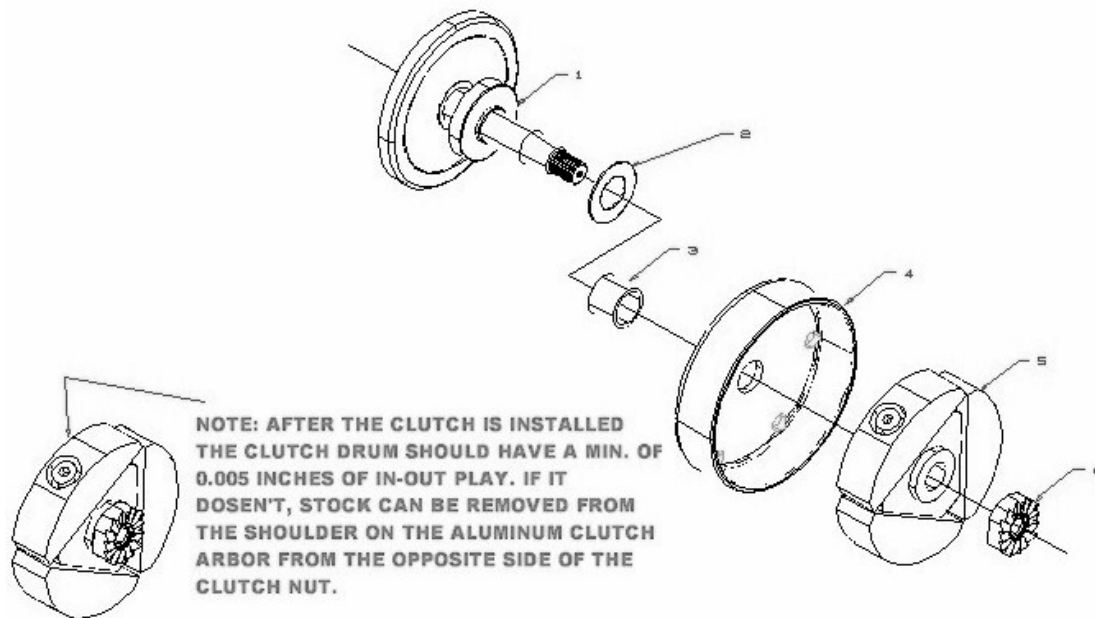

Figure 39, Clutch Assembly Drawing

CLUTCH ASSEMBLY:

1. After cleaning or replacing the spring washers, reassemble the stack up of washers.

CAUTION:

It is important to reassemble the washer stack to that recommended or to your own specialized stack.

CAUTION:

It is also important that all three shoes are stacked the same. (See figure 34)

2. Clean the threads of the stack bolt and the clutch with contact cleaner removing all old thread locking material.
3. Apply high strength (red) thread lock material to the stack bolt and tighten as tight as possible without stripping the Allen head.

CAUTION:

Avoid allowing excess thread lock material to contact the spring washers and the clutch or the clutch is likely to malfunction.

4. Use fine emery paper on the center hole of the clutch and on the tapered section of the crankshaft.
5. Apply a small amount of wicking / bearing retainer (green) thread lock agent to the center tapered section of the crankshaft and taper of clutch arbor.

CAUTION:

Lean the bike / engine such that any excess thread lock agent goes away from the bushing in the clutch drum.

6. Put the clutch back in.
7. Apply high strength (red) thread locking agent to the threads and install the nut and torque to 40 ft-lb (54Nm) with the special socket (see figure 35).

CAUTION:

Use high strength (red) thread locker on the threads of the clutch nut. If you are using an impact socket, just zap it lightly with an air wrench to tighten it because there are only about 4 threads inside the nut and they can be easily stripped. If you are tightening it by hand, you can very carefully use a 3/4" piece of wooden dowel rod inside the exhaust port to block the piston so you can tighten the nut. Do not use something harder than your aluminum piston and do not crush the top of the piston into the ring.

INSPECTION NOTE:

- There must be in / out play in installed clutch, 1.0 mm (0.04") maximum.
- Excess in/out will cause early crank seal failure.
- A blue clutch drum is worn out from excessive slippage or improper lubrication.
- Should be no looseness in clutch shoes.

8. Install the clutch cover taking care to put the two longer bolts in their proper locations and tightening in the order specified in figure 36. (5mm hex key, 5.8 ft-lb, 7.8 Nm).

CAUTION:

Prior to tightening the six clutch cover bolts, press the kick lever down to ensure proper kick gear alignment.

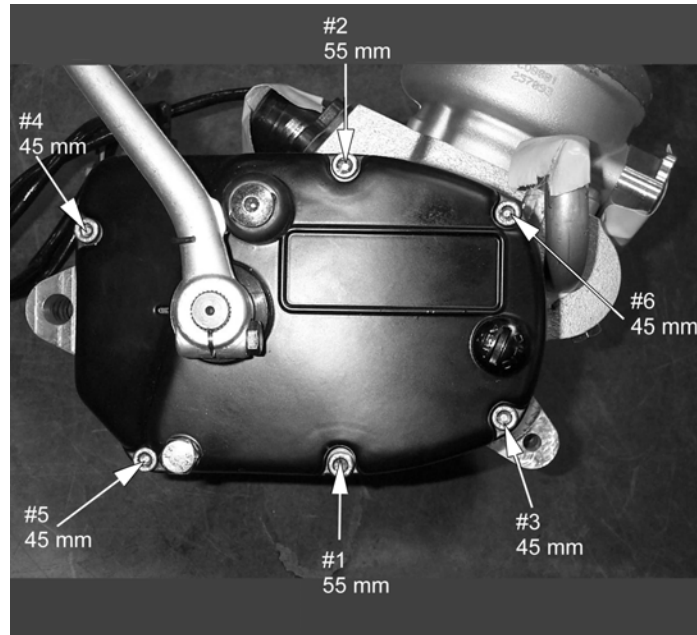

Figure 40

9. Put pipe back on and add oil (235 ml (8.0 oz) *Cobra 3 Shoe Clutch Milk* (Part # MCMUGF01) or Dexron III ATF.

Ignition

Stator care

Stator failure will result from running the bike hot. Following is a list of things that will make your engine run hot.

1. The timing should not exceed the maximum specifications listed.
2. Improper carburetor jetting.
3. Improper spark plug heat range. Never run a hotter plug than the specified spark plug.
4. Clutch slippage. See “CLUTCH” section for causes of slippage.

CAUTION:

- Because of the amount of heat generated by the clutch and engine during extended periods of riding, it is advisable to remove the ignition cover afterward to allow the ignition to cool off. The heat transfers through the cases and can damage the stator as it cools off because of lack of airflow around the stator. Spray the stator and rotor with CRC 3-36 or WD-40 and let it drip

dry or blow it off a little with an air nozzle.

- Ignition will overheat if the gap between the rotor and stator is not large enough. There should be even clearance as the rotor rotates relative to the stator.
- Non-resistor spark plug caps should be used. Resistor caps will result in a weaker spark that will reduce performance.
- Make sure ground wires are secure.
- Make sure connections are free of dirt.

CAUTION:

If the engine is hot, it is EXTREMELY important to take the ignition cover off, put a fan on it to let it cool, and spray it with CRC 3-36 or WD-40. Proper stator care is important for the durability of the ignition system. (Stator- Part # ICMU0007)

The proper ignition timing for this model of is at **0.050"** before Top Dead Center (that means 0.050" (1.3mm) before the piston reaches the highest point of it's travel in the cylinder).

CAUTION:

Advancing the ignition timing will cause the engine to run hotter, in-turn causing power loss, shortened clutch life, and possibly lead to premature stator failure, and can also cause detonation which can lead to premature piston and ring failure.

Tools recommended for timing service:

- Compact motorcycle dial indicator
- Universal clutch puller- a universal puller that pulls the clutch, main drive gear and rotor. (Part # MCMUTL70).

TIMING YOUR IGNITION:

1. Remove the spark plug cap, and sparkplug.
2. Insert the dial indicator into the spark plug hole.
3. Remove the four 8/32" X 1 3/4" bolts from the ignition cover.
4. Remove the water pump belt from the rotor and water pump shaft.
5. Turn the crankshaft counterclockwise until it reaches top dead center.
6. Set the dial indicator to zero
7. Turn the crankshaft clockwise until the dial indicator reaches 0.05)" (1.3mm) from top dead center.
8. Line up the lines on the stator and the rotor (figure 37). Otherwise loosen the three 10X32 bolts to adjust the stator.

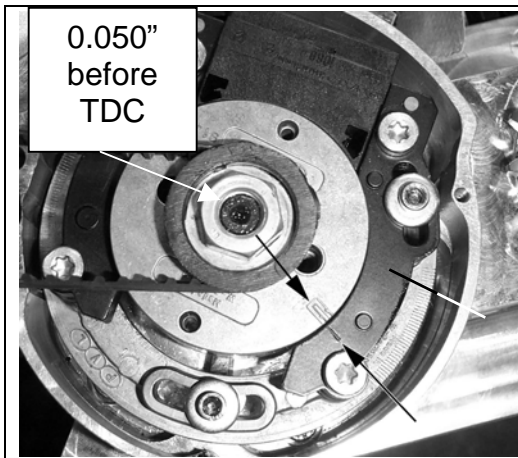

Figure 41, Lining up the line on the rotor with the line on the stator.



Figure 42, Using a dial indicator to measure piston height for setting ignition timing.

ROTOR INSTALLATION:

1. Use wicking / bearing retainer (green) thread locker on the inside of the rotor, and on tapered part of crankshaft.

CAUTION:

It is recommended that you apply the proper thread locking primer to the components that are to receive thread locking material per the manufacturers instructions.

2. Eyeball the lines on the rotor and stator then press the rotor onto the crankshaft firmly (figure 37).
3. Torque the nut on the rotor to 40 ft-lb (54 Nm).
4. Recheck the timing following the procedure of *timing your ignition*.
5. Install the water pump belt back on.
6. Bolt the ignition cover back on.
7. Put the spark plug back in, and firmly stick the spark plug cap onto the spark plug.

Cooling System

The water pump in the engine keeps the radiator fluid in circulation throughout the motor. The air stream running through the radiator cools the radiator fluid. Therefore dirty radiators additionally reduce the cooling effect.

Radiator fluid removal:

1. Remove the coolant drain plug (A) on the front of the engine case (figure 39).

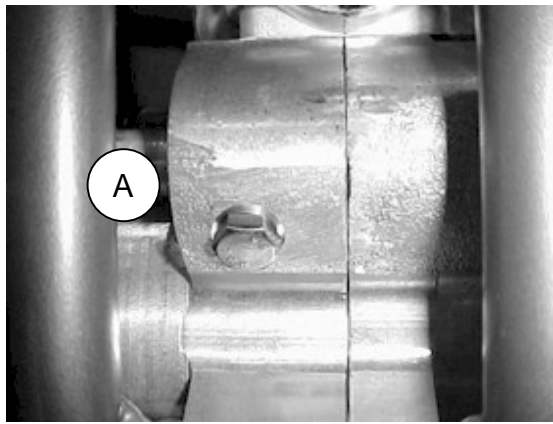

Figure 43

To remove radiator cap:

1. Turn the cap counter clockwise to the first stop and wait there for a few seconds.
2. Push the cap down and turn it further in the same direction and remove the cap.

NOTE: Inspect the old coolant for visual evidence of corrosion and abnormal smell.

Fill the radiator up to the bottom of the radiator filler neck with coolant. Install the cap, turning it clockwise about $\frac{1}{4}$ turn.

Tools recommended for impeller service:

- Flat head screwdriver
- 5mm hex key
- 13mm- hex wrench
- 1/8" hex key
- 9/64" hex key
- 3/32" hex key
- Propane torch
- 3/8" diameter x 8" long steel rod
- Hammer

COBRA IMPELLER SERVICE INSTRUCTIONS

1. Remove exhaust pipe and gas tank (you will be using a propane torch in step 12).
2. Remove radiator cap and drain engine coolant by removing the 13mm- hex head coolant drain plug.
3. If the impeller is damaged or broken completely back flush the coolant system to ensure no solid pieces are in the system.
4. Remove foot brake.
5. Drain engine transmission oil by removing drain screw using a 13mm- hex wrench. (item 2 in the figure below).
6. Remove kick-starter cover using a 5mm hex key. (item 3 six places)
7. Remove clutch and basket.
8. Unscrew water elbow fitting. (Figure 40)

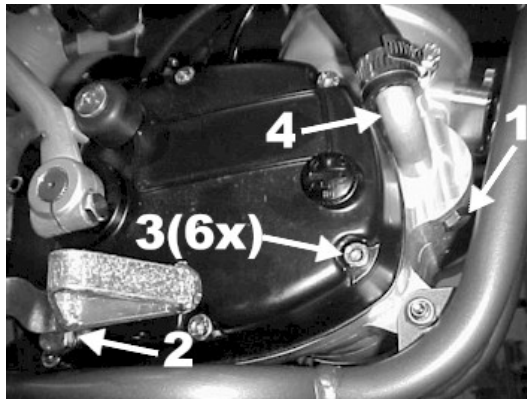

Figure 44

8. Remove ignition cover using a 9/64" hex key (four places)
9. Remove belt retainer screw using a 1/8" hex key. (Figure 41 - item 1)
10. Remove belt retainer, water pump belt and water pump fan pulley.
11. Remove bearing retainer screw using a 3/32" hex key. (Figure 41 – item 2)

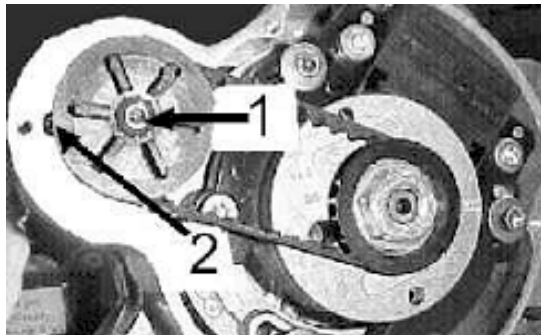

Figure 45

12. Heat engine case around area of impeller lightly with a small Burnsmatic propane torch. Using a 3/8" diameter x 8" long steel rod, tap impeller assembly out of engine as shown in figure 42.

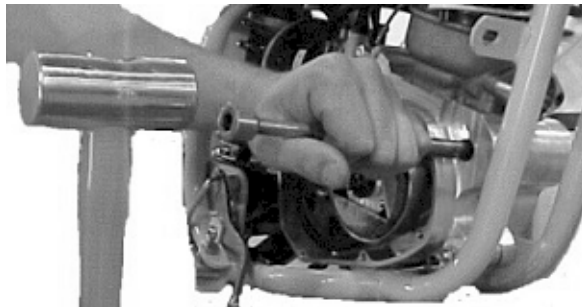

Figure 46

CAUTION:

Too much heat can be detrimental to the engine cases.

13. The shaft assembly is serviceable. Use a 1/8" hex key to remove impeller retainer screw. Remove impeller, seal and both bearings. Check shaft for wear in the area of the seal. If there is any sign of wear (like a groove) replace the shaft.

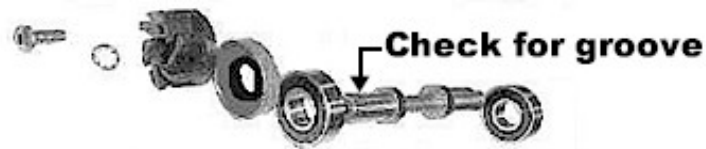

Figure 47

14. Reinstall new bearings, seal and impeller. Clean all threads and use green (wicking / bearing retainer) thread locker.
15. Using a liberal amount of grease on the outside seal, bearings and inside of case, reinstall bearing assembly by using a 0.500" ID by 1.000" OD steel tube 2" long and tap on end of tube per figure 44.

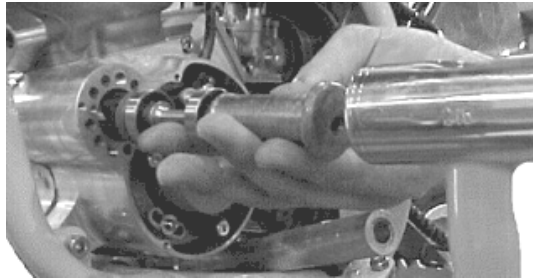
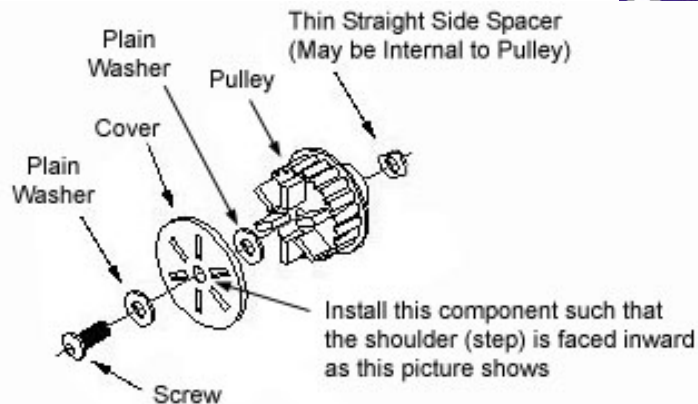

Figure 48



16. Re-assemble in same order of disassembly.

CAUTION:

Clean all threads and use green (wicking / bearing retainer) thread locker on the belt retainer screw.

NOTE:

Apply Ultra black Hi-Temp RTV silicon gasket maker to the threads of the water pump 90° elbow fitting before assembly.

NOTE:

Refill the coolant system with 50/50 antifreeze-coolant / distilled water.

CAUTION:

Do not mix Propylene Glycol based coolant / antifreeze solutions with Ethylene Glycol based coolant / antifreeze solutions.

Fuel & Air System

Carburetor:

Tools recommended for carburetor service:

- Small flat head screwdriver
- WD-40
- 8mm socket

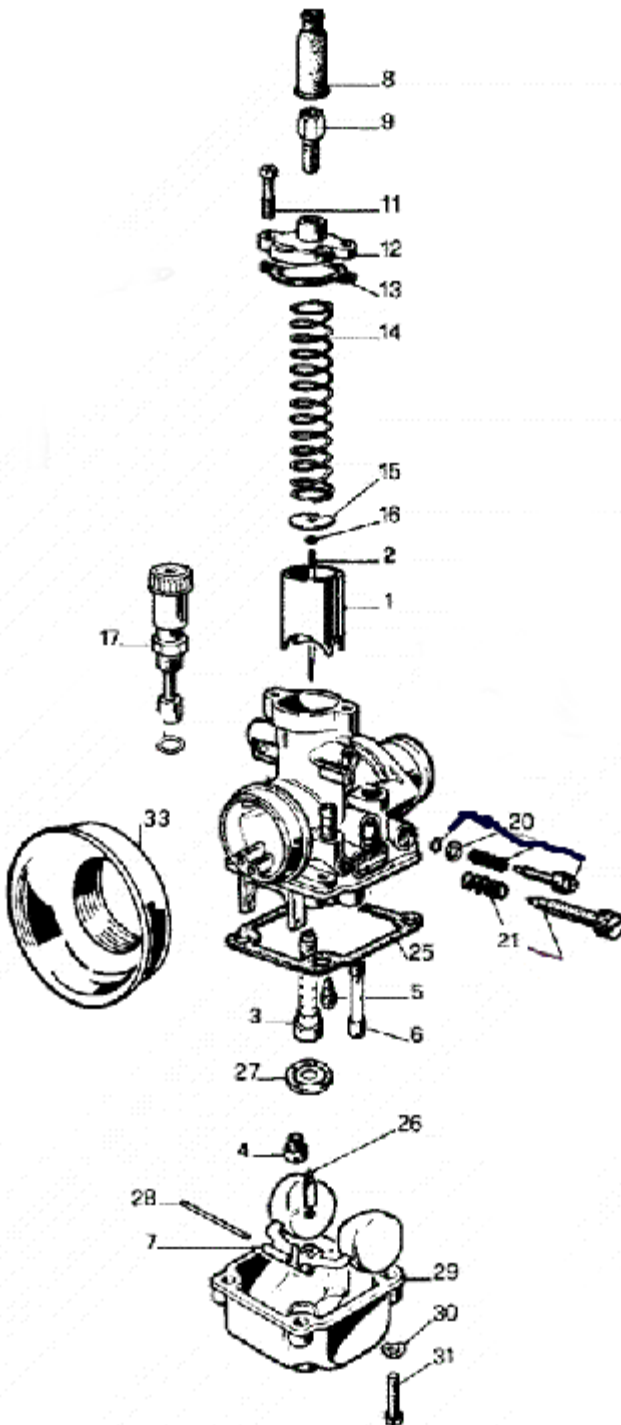

Carburetor		
REF. #	PART #	DESCRIPTION
	RCCM0001	COMPLETE CARBURETOR 14MM
1	RCMU0305	CARB SLIDE
2	RCMU0601	NEEDLE
3	RCMU0002	ATOMIZER
4	RCMU0092	MAIN JET
5	RCMU0055	PILOT JET
6		CHOKE JET
7	RCMU0301	FLOAT
8	RCMU0102	RUBBER CABLE CAP SEAL
9	RCMU0003	CABLE ADJUSTER
11	RCMU0006	TOP CARB SCREW
12	RCMU0106	CARB TOP
13	ZCMU0007	TOP CARB GASKET
14	RCMU0004	SLIDE SPRING
15	RCMU0205	NEEDLE RETAINER PLATE
16	RCMU0007	NEEDLE CLIP
17	RCMU0204	CHOKE ASS'Y. 2001 CM
20	RCMU0009	FUEL MIXTURE SCREW
21	RCMU0011	IDLE ADJUSTMENT SCREW
25	RCMU0103	FLOAT BOWL GASKET
26	RCMU0107	FLOAT NEEDLE
27	RCMU0012	DIFFUSER
28	RCMU0016	FLOAT RETAINER PIN
29	RCMU0106	FLOAT BOWL
30	RCMU0201	BOTTOM FLOAT SCREW
33	RCCM1301	VELOCITY STACK
	RCCM0314	14MM CARB RESTRICTOR

Figure 49

Your Cobra is equipped with an adjustable carburetor. Some fine-tuning may be needed according to weather condition and altitude. Proper jetting is **very** important for engine performance and engine life. Serious damage to the engine can occur if not properly adjusted.

IDLE ADJUSTMENT:

On the left side of the carburetor, there are two adjustment screws. The larger screw with the knurled head is the idle adjustment screw. To raise the idle, turn the screw in clockwise (in 1/4 turn increments) and rev the engine after each adjustment. To lower the idle, turn the screw counter-clockwise.

TOP END JETTING:

Indications that the engine is running too rich (too much fuel for the air) are:

- Engine not revving out or blubbering at high RPMs.
- Engine will not 'clean out'
- Wet or black spark plug

NOTE: Before changing jetting be sure that the air filter is properly cleaned and has the usual amount of air filter oil. An overly dirty air filter can cause the engine to run rich.

If the engine is running rich on the top end it should be leaned out. Leaning it out can be done by:

1. Changing the main jet to a smaller number.
2. Raising the needle clip (this lowers the jet needle) one notch at a time on the slide.

Indications that the engine is running too lean are:

- Engine cutting out on top end.
- Engine overheating and ultimately seizure.
- White spark plug

CAUTION:

It is much safer to operate the engine slightly rich as opposed to slightly lean. This is because an overly rich engine will just run poorly while an overly lean engine will seize, potentially causing an expensive top end rebuild and a DNF.

To richen the carburetor:

1. Change the main jet one number at a time (larger).
2. Lower the needle clip (raising the jet needle) one notch at a time until the engine starts to blubber on the top end, then move the clip back up one notch or until you get the blubber out.

FUEL MIXTURE SCREW

The smaller brass screw that is towards the front of the engine is a fuel mixture screw. This screw will also richen and lean your engine more on the bottom and mid-range. In warmer conditions, turn the screw in. In colder conditions, turn the screw out. Be sure to keep the carburetor very clean and make sure you don't

have water or dirt in the carburetor bowl. Use automotive carburetor cleaner or WD-40 to clean the carburetor inside and out.

STOCK CARBURETOR SETTINGS

The 2003 KING stock carburetor settings from the factory are:

- 55 pilot jet
- 92 main jet

Cleaning the carburetor:

⚠ WARNING

Clean the carburetor in a well-ventilated area, and take care that there is no spark or flame anywhere near the working area; this includes any appliance with a pilot light. Because of the danger of highly flammable liquids, do not use gasoline or low flash-point solvent to clean the carburetor.

1. Make sure the fuel is shut off.
2. Remove the carburetor.
3. Drain the fuel from the carburetor.
4. Disassemble the carburetor.
5. Immerse all the metal parts in a carburetor cleaning solution.
6. After the parts are cleaned, dry them with compressed air.
7. Blow out the fuel passages with compressed air.
8. Assemble the carburetor
9. Install the carburetor onto the motorcycle.

CAUTION:

1. The motorcycle will only operate properly if the carburetor top is installed properly with the mounting screws, cable and choke knob oriented as shown in figure 46.

Figure 50 Proper carburetor top installation and location of rectangular slide indexing pin and vent elbows.

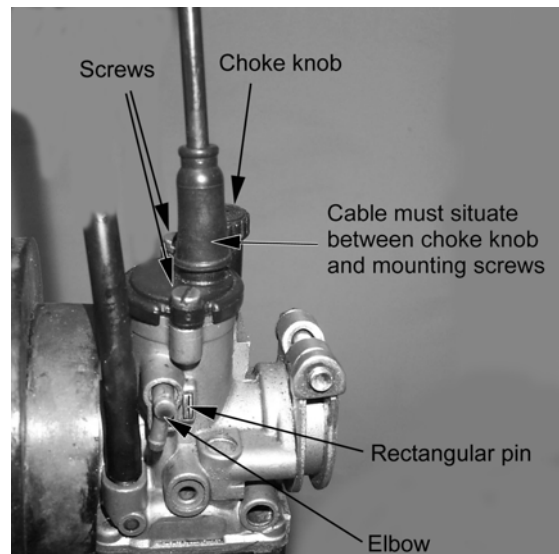

Reeds:

- The reeds must lay flat on the reed cage.
- If the reed tips aren't lying flat, replace them immediately.
- The reeds must have a tight seal on the reed cage.
- If the reed is damaged in any way, replace it. This means cracks, chips, and ruptures. Anything abnormal, replace the reeds.

Take the reed cage out and hold it up to the light and look in through the cage. If you see light between the reed pedals and the frame, then replace the reeds. If you do not see light, then the reeds should be ok. (See figure 47)

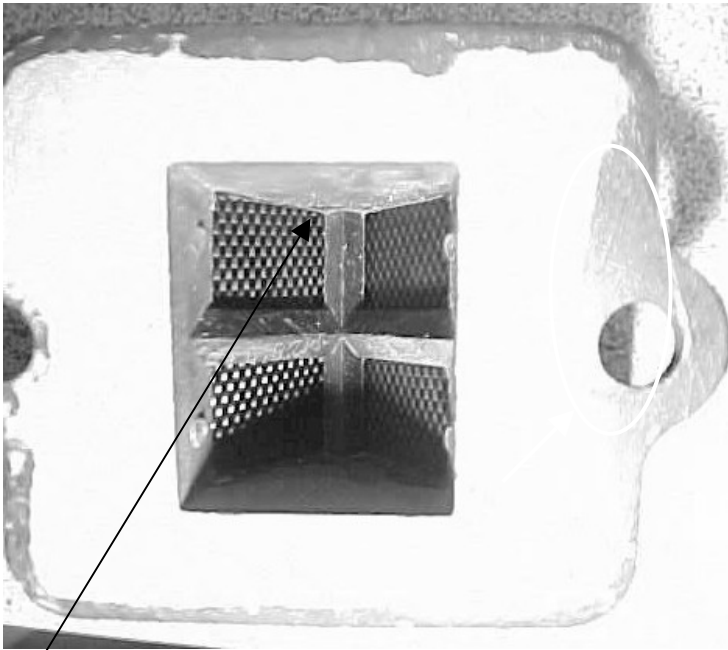

Figure 51

The presence of light indicates that the reeds should be replaced, or possibly turned over.

Exhaust

The pipe is a crucial element to a motorcycle. Any kinks, dents, or damage done to the pipe will result in a major performance loss.

NOTE:

Be sure to take the pipe off, and any carbon that may be built up. Carbon build up is created from exhaust. Exhaust has oils in it, and the oils cling to the walls of the inside of the pipe. Over a long period of time, the diameter of the pipe will decrease, due to carbon build up. So it is essential to clear the residue.

CAUTION:

It is important to repack the silencer. Signs of your silencer needing to be repacked are:

- The bike is louder than normal.
- A loss of power.

Wheels & Tires

Rear wheel

Rear wheel dampening

Tools recommended for wheel service:

- 13mm socket
- Flathead screwdriver
- 11mm wrench or socket
- 19mm wrench

The Cobra is the only 50cc to have the rear wheel damping system. This feature prevents engine impact shock caused by hard landings. This design allows the cushioned sprocket to move forward and backwards separately from the wheel. After each moto, check the 4 rubber dampers, spacers and bolts for fatigue. You should keep extra rubber dampers in your toolbox (part # PCMU0059). Different sized sprockets are also available.

Watch for bending and warping of the outside rear damper plate. If it is bent or warped, the rubber dampers in the sprockets do not last as long as when using a straight unit. Usually you can straighten the plate with a hammer or just flip it over.

Changing the rubber dampers:

1. Remove the four bolts with the 11mm wrench
2. Take the backing plate off
3. Observe the four rubber dampers, and pull the sprocket upward to remove it.

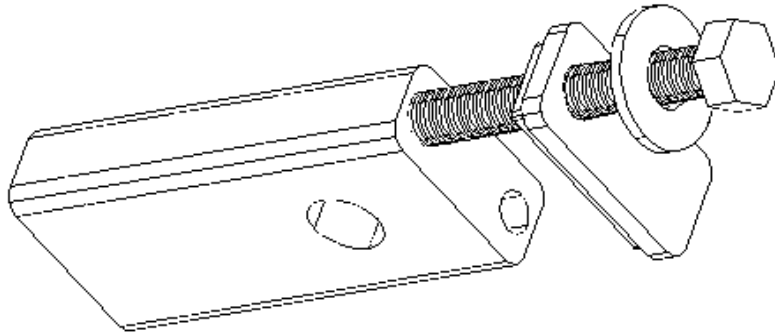

Figure 52

1. Pop the four rubber dampers out of the sprocket.
2. Push the rubber dampers into the sprocket.
3. Place the sprocket with rubber dampers, onto the aluminum studs.
4. Place backing plate over the dampers and sprocket.
5. Insert the 11mm bolts into the holes and tighten to 18 ft-lb (24 Nm).

Rear wheel pullers

Disassembly:



1. Remove axle, and back wheel assembly.
2. Pull the rear wheel pullers out of the back of the swing arm.

Figure 53

Rear wheel alignment:

By eye, ensure that the rear sprocket is running true (in-line, planar) with the front sprocket. When the sprockets are running true, the wheel is properly straightened, and the chain will run straight.

Suspension

See the parts and optional components sections of this manual for the springs and valving available for heavier and lighter riders.

Front forks tuning

The front forks are designed with the damping components in separate fork legs. The **compression damping** duties are performed in the **right fork leg** and the **rebound damping** duties are performed in the **left fork leg**. This allows easy adjustment of the damping characteristics by appropriately changing the viscosity of the fork oil in the fork leg controlling the damping characteristic that need changed.

Example: If stiffer compression damping is required, switch from 20 (standard), to 25 or 30 weight fork oil in the right fork leg. If softer rebound damping is required, switch from 20 (standard) to 15 or 10 weight fork oil in the left leg.

NOTE:

Fork oil level affects bottoming harshness, and fork oil viscosity affects valving speed.

Troubleshooting

1) Engine not behaving properly

- a) Carburetor top is installed backwards (happens a lot)
- b) The carburetor slide indexing pin is missing

2) Engine is down on power

- a) Clutch engagement is not set properly
- b) Jetting is incorrect
- c) Silencer needs repacked
- d) Exhaust pipe
 - i) Has excess carbon buildup
 - ii) Has large dent in it
- e) Compression is low
 - i) Piston
 - ii) Rings
- f) Reeds are damaged
- g) Ignition timing is incorrect

3) Engine is excessively loud

- a) Silencer needs repacking

4) Engine 'blubbers' at high RPMs

- a) Jetting too rich

5) Engine won't start

- a) Fuel
 - i) None in tank
 - ii) Is sour or bad
- b) Carburetor is dirty
- c) Ignition
 - i) Spark plug fouled
 - ii) Spark plug cap off
 - iii) Engine Shut-off 'kill' switch is shorted
 - iv) Bad electrical ground
 - v) Stator winding damaged
- d) Exhaust is plugged

6) Engine won't idle

- a) Idle knob needs adjusted
- b) Carburetor jets are dirty

Index

Air Filter		Forks	
Maintenance.....	16	Adjustment.....	68
Airbox		Parts	29
Parts.....	19	Frame Parts	31
Bars and Controls	20	Front Brake	
Break-In	9	Adjustment.....	15
Carburetor		Parts	34
Parts.....	21	Front Wheel Parts	35
Service	62	Fuel System	
Specifications	5	Service.....	62
Chain		General Tips.....	11
Adjustment	14	Hardware and Fasteners	
Chassis		Frame	31
Specification	5	Plastic.....	36
Clutch		Ignition	
Parts.....	25	Parts	26
Service	51	Service.....	56
Clutch Lubricant		Timing.....	57
Replacing	13	Jetting	
Compression test.....	42	How To	63
Cooling System.....	58	Stock.....	5
Damper	66	Lubrication	
Electrical		Recommended	5
Parts.....	23	Maintenance	
Engine		schedule	12
Parts List	20	tips	12
Specifications	5	Oil	
Exhaust.....	65	Recommended	5
Parts.....	28	Optional Components.....	8
Fork Oil		Parts	
Replacement	17	Airbox and Filter.....	19

Bars and Controls.....	20	Damper.....	66
Bottom End & Transmission.....	24	Parts.....	38
Carbutetor.....	21	Pullers.....	67
Clutch & Kick Starter.....	25	Reeds.....	64
Coolant System.....	22	Shock	
Electrical.....	23	Parts.....	39
Engine.....	24	Spark Plug	
Exhaust.....	28	Recommended.....	5
Forks.....	29	Specifications.....	5
Frame.....	31	torque values.....	7
Front Brake.....	34	Starting.....	10
Front Wheel.....	35	Swingarm Parts.....	40
Ignition & Water Pump.....	26	Tips.....	11
Inlet.....	19	Top End	
Plastic & Seat.....	36	Parts.....	27
Rear Brake.....	37	Service.....	41
Rear Wheel.....	38	Torque Values.....	7
Shock.....	39	Transmission	
Swingarm.....	40	Specifications.....	5
Top End.....	27	Transmission Lubricant	
Triple Clamps.....	29	Replacing.....	13
Parts List		Troubleshooting.....	69
Engine.....	20	VIN reading.....	11
Plastic & Seat Parts.....	36	WARNING.....	2
Pullers.....	67	Water Pump	
Rear Brake		Parts.....	26
Adjustment.....	15	Wheels	
Parts.....	37	Service.....	66
Rear Wheel			