

DISCLAIMER OF WARRANTY

This motorcycle is sold "as is" with all faults, obvious or not. There are no warranties expressed or implied, including any warranty of merchantability and warranty of fitness for any particular purpose.

"WARNING"

THE COBRA CX65CARD IS A COMPETITION MODEL ONLY AND IS **NOT** MANUFACTURED FOR, NOR SHOULD IT BE USED ON PUBLIC STREETS, ROADS OR HIGHWAYS.

THE USE OF THIS BIKE SHOULD BE LIMITED TO PARTICIPATION IN SANCTIONED COMPETITION EVENTS UPON A CLOSED COURSE BY A SUFFICIENTLY SKILLED RIDER AND SHOULD NOT BE USED FOR GENERAL OFF-ROAD RECREATIONAL RIDING.

IMPROPER USE OF THIS MOTORCYCLE CAN CAUSE INJURY OR DEATH.

THIS BIKE IS INTENDED FOR EXPERIENCED RACERS ONLY AND NOT FOR BEGINNERS.

IT IS YOUR RESPONSIBILITY AS THE OWNER OF THIS COBRA MOTORCYCLE OR AS THE PARENT, OR LEGAL GUARDIAN OF THE OPERATOR, TO KEEP THIS COBRA MOTORCYCLE IN PROPER OPERATING CONDITION.

THIS BIKE WAS DESIGNED FOR RIDERS THAT WEIGH LESS THAN 110 LBS WITH FULL RIDING GEAR AND SHOULD NOT BE OPERATED BY RIDERS THAT WEIGH MORE THAN THAT.

BE SURE THAT THE RIDER ALWAYS WEARS ADEQUATE SAFETY GEAR EVERYTIME HE OR SHE RIDES THEIR COBRA MOTORCYCLE.

IMPORTANT SAFETY NOTICE

WARNING

Failure to follow WARNING instructions could result in severe injury or death to the machine operator, a bystander, or a person inspecting or repairing the machine.

CAUTION:

A CAUTION indicates special precautions that must be taken to avoid damage to the machine.

NOTE:

A NOTE provides key information to make procedures easier or clearer.

Table Of Contents

GENERAL INFORMATION.....	3
SPECIFICATIONS - GENERAL	3
OPTIONAL COMPONENTS.....	4
SPECIFICATIONS - TORQUE VALUES	5
BREAK-IN PROCEDURE.....	6
STARTING PROCEDURE	7
MAINTENANCE	8
TIPS	8
SCHEDULE	8
REPLACING TRANSMISSION / CLUTCH LUBRICANT.....	10
CHAIN ADJUSTMENT	11
AIR FILTER CLEANING	12
FORK OIL REPLACEMENT	13
IGNITION TIMING	14
PARTS.....	15
PARTS – AIRBOX & INLET SYSTEM	15
PARTS – BARS AND CONTROLS.....	16
PARTS - CARBURETOR	17
PARTS – CLUTCH ACTUATION	18
PARTS – COOLANT SYSTEM.....	19
PARTS – ELECTRICAL SYSTEM.....	20
PARTS – ENGINE CLUTCH.....	21
Parts – Engine – Clutch / Kick Cover.....	22
Parts - Engine - Ignition Side	23
Parts - Engine – Kick Mechanism	24
Parts – Engine – Shift Mechanism.....	25
Parts – Engine – Top End.....	26
Parts - Engine - Transmission.....	27
PARTS – EXHAUST SYSTEM.....	28
PARTS – FORKS – LEG ASSEMBLY	29

PARTS – FRAME & TRIPLE CLAMPS	30
PARTS – FRONT WHEEL & BRAKES	31
PARTS –BODYWORK	32
PARTS – REAR BRAKE	33
PARTS – REAR WHEEL.....	34
PARTS – SHOCK	35
PARTS – SWINGARM ASSEMBLY.....	36
SERVICE	37
ENGINE SERVICE	37
Base Gasket Selection	38
FUEL & AIR SYSTEM	40
TUNING	43
GEARING.....	43
SUSPENSION	44
CARBURETION	45
TROUBLESHOOTING	48
INDEX.....	50

General Information

Specifications - General

Items	CX65 CARD
Dimensions	
Wheelbase	40.9" (1040mm)
Wheel size	12" (305mm) rear, 14" (356mm) front
Seat height	29.9" (760mm)
Engine	
Type	2-stroke, single cylinder, reed valve
Cooling system	Liquid-cooled
Coolant	50/50 antifreeze-coolant / distilled water
Displacement	64.9 cc
Bore and stroke	44.5 mm x 41.7 mm
Ignition system	Electronic, digital advance
Spark plug	Champion 8339-1, 8332-1 hotter, 8904-1 colder
Gap	0.023" – 0.025" (0.58 – 0.64 mm)
Ignition timing	Digital advance (set at TDC)
Fuel type	High octane pump gasoline
Oil type	<i>Cobra Venom 2-cycle Race Oil</i>
Fuel / oil mix ratios	Between 32:1 and 40:1 (after engine Break-In)
Carburetion	28 mm Keihin PWK
Main Jet / Slow (Pilot) Jet	140 / 55
Needle	
Float Height	
Transmission	
Speed	6 speed
Final drive ratio	15/48, 14/45
Chain	116 links 420
Transmission / clutch oil type	Quality gear lubricant, or Cobra clutch milk Do Not Run Automotive Motor Oil
Quantity	530 ml (18.0oz)

Chassis	
Front tire	60/100 – 14
Rear tire	80/100 – 12
Front fork	Marzocchi 35mm USD, Compression adjustable
Fork oil type	SAE 10 weight
Fork oil amount	210 ml (7.1oz)
Spring Preload Length	178mm (49 N/mm)
Rear shock	Öhlins: Compression & Rebound Adjustable
Spring rate	280 lb/in (49 N/mm)

Optional Components

Call your dealer, or the factory, for details

- Carburetor jets
- Pre filter for the airbox
- Tires, tubes or 'Tire Balls'
- Sprockets
 - Front
 - Rear
- Suspension Springs

Weight of Rider (lb)	Fork Spring	Shock Spring
less than 75 lb		42 N/MM (240 lb/in) SCC60240P (white)
75-90 lb	0.24 kg/mm KCC60024	45 N/MM (260 lb/in) SCC60260P (black)
90-100 lb	0.26 kg/mm KCC60026	49 N/MM (280 lb/in) SCC60280P (yellow)
Greater than 100	0.28 kg/mm KCC60028	53 N/MM (300 lb/in) SCEX1300 (red)

Specifications - Torque Values

Fastener	Torque Value			Size & Remarks
	ft-lb	in-lb	Nm	
Cylinder head nuts	12.5	150	17	M7 x 1.0
Crankcase bolts	8.8	105	12	M6 x 1.0
Spark plug	(SP)	(SP)	(SP)	M14 x 1.25
Stator bolts	2.1	25	2.8	M5 X 0.8
Stator cover bolts	1.7	20	2.3	M4 X 0.75
Clutch cover bolts	5.8	70	7.9	M6 X 1.0
Clutch nut	35	420	47	M10 x 1.25*
Front axle bolt	10	120	13.5	M14 x 2.0
Front axle pinch bolt	7.4	88.5	10	M6 X 1.0
Engine mount bolts	22	265	30	M8 X 1.25
Swingarm Pivot	21	250	28	M12 X 1.5
Intake manifold bolts	4.6	55	6.2	M6 X 1.0
Rear Axle Bolt	25	300	34	M14 X 1.5
Rear Sprocket Bolts	20	240	27	M8 X 1.25
Triple clamp bolts	6	72	8	M6 x 1.0
Fork cap	15	177	20	
Fork Damper Nut	11	133	15	
Ignition rotor nut	40	480	54	M10 x 1.25*

* Apply high strength thread locking agent when installing

(SP) To apply the proper torque to the spark plug when inserting, one must first screw the spark plug in until the metal gasket ring causes resistance and then turn another 1/8 to 1/4 turn.

Break-In Procedure

Your Cobra CX65 is a close-tolerance high performance machine and break-in time is very important for maximum life and performance. The CX65 can be ridden hard after the first ½ hour break-in time but it is recommended that no adjustments are made to the carburetion or suspension until the full 8 hours of bike break-in has elapsed. Also, after the engine, transmission, and drive train have been broken-in for the full 8 hours, the bike will be faster!

Use a fuel / oil mixture of 32:1 for the full 8 hour break-in period. Be sure to use high octane pump gas with Cobra's specially formulated *Cobra Venom 2-cycle Race Oil*. (Part # MCMUOL02)

CAUTION:

Failure to use proper fuel, oil, or fuel/oil mixture may result in premature engine wear or damage to the machine.

Adhering to the following break-in schedule will result in long lasting high performance machine.

- Start bike on stand
- First 5 minute period, operate the bike on the stand with a combination of idle and high RPM operation. (avoid prolonged high RPM but spin the rear wheel good at least once or twice per minute)
- Allow bike to cool
- Ride for 15 minutes maximum (avoid prolonged high RPM operation and avoid abusing the clutch).
- Cool and inspect bike for loose fasteners.
- Check & retighten wheel spokes
- Next ½ hour of operation, avoid prolonged operation at Wide Open Throttle.
- After 1 hour of operation
 - Check for loose bolts and nuts on the bike and retighten as necessary (proper torque values are listed under Specifications).
 - Clean the carburetor bowl.
 - Change the transmission / clutch lubricant.
- After 8 hours of operation
 - Change the fork oil.
 - Have a Certified Cobra Mechanic change the shock oil.
- Your bike is now ready for the highest level of competition!

NOTE:

During break-in the bike will likely lose some engine coolant through the radiator overflow hose. Losing up to 4 oz (120 ml, ½ cup) is normal. Proper coolant level will cover the top of the radiator cores. Removing the radiator cap and looking inside is the only way to check the coolant level.

WARNING

Never open the radiator cap of a machine that has a hot or warm engine or one that has recently been ridden. Burning and scalding could occur.

CAUTION:

It is important that the radiator cap is installed correctly and completely otherwise engine damage could occur.

Starting Procedure

Before starting the machine inspect the following:

- Check for proper tire pressure in both tires.
- Observe the chain tension and adjust if necessary.
- Observe the coolant level and fill if necessary.
- Verify that the chain rollers and sliders do not have improper wear.
- Verify that the handlebars are tight.
- Check the throttle for smooth operation and sound closing.
- Check for loose bolts and nuts, and re-torque as necessary.
- Verify that the air filter is clean and properly saturated with oil.
- Insure that the fuel tank contains an adequate volume of fuel / oil mixture to complete the distance required. (High octane pump gas with Cobra's specially formulated *Cobra Venom 2-cycle Race Oil*)
- Turn the fuel on by rotating the fuel petcock lever to the vertically downward position.

CAUTION:

For best results from your Cobra Motorcycle use only the recommended fuels. 'Race' fuels can be used, however, they are not required with the stock engine, and the engine will require addition attention to maintain proper jetting as weather condition change throughout the day.

WARNING

Always wear a helmet and other protective riding gear.

When your pre-ride inspection is complete the bike may be started. For a cold engine follow this procedure.

1. Place the motorcycle on a stand of sufficient strength that positions the motorcycle in a level upright position with the rear wheel off the ground.
2. Engage the choke by pulling out on the choke button until it stops.
3. Kick start the engine.
4. Rev the engine in short spurts, turning the throttle no more than 1/4 open until the engine will run without the choke.
5. Verify a functional engine shut-off switch by shutting off the engine.
6. Restart the engine and proceed with riding when the engine is sufficiently warm (i.e. the side of the cylinder is warm to touch).

CAUTION:

Never rev an engine full throttle when it's cold or slightly warmed up. This may lead to premature wear of engine components or complete cold seizure of the engine.

CAUTION:

Cobra recommends that you tell your child to take it easy the first couple of minutes in practice until the engine comes up to full operating temperature.

Maintenance

It is important that you adhere to this maintenance schedule so as to promote the longevity of your Cobra Motorcycle.

Tips

1. Cobra lubricants:
 - a. Use only high quality transmission oil designed specifically for two-stroke racing engines.
 - b. Cobra Two Cycle Oil exceeds the JASO FD & ISO-L-EGD specifications, which are the world's most stringent requirements on lubrication, detergency, and smoke.
2. Fill your transmission only with the recommended amount of oil. Overfilling may lead to premature seal failure.
3. The cylinder base gasket has been 'fitted' for your engine. See the service section of this manual for instructions how to properly size a base gasket during an engine rebuild.
4. Evaluate the bikes jetting only after it has been warmed up to race temperatures.
5. A properly maintained machine is safer, faster, and more fun to ride.
6. New chains will stretch on first use. Never install a new chain prior to a race. Always 'break' them in during practice.
7. Your Cobra Motorcycle has a 10 digit VIN (Vehicle Identification Number). The first two digits indicate the model and the seventh indicates the model year (MY).
 - a. Example, CXxxxx7xxx is a 2007 MY CX65.

Schedule

- Between each ride
 - Check the air filter (clean and re-oil as necessary).
 - Insure the smooth operation of the throttle cable (throttle soundly 'clacks' shut).
 - Check for frayed strands of the throttle cable inside the throttle housing and replace if necessary.
 - Check for adequate tire pressures and adjust if necessary.
 - Check all nuts and bolts for proper torque and re-torque if necessary.

- Spray all moving parts with WD40 or other water displacing oil.
- Check drive chain for
 - Proper tension and adjust if necessary.
 - Adequate lubrication and lubricate if necessary.
- Insure that the ignition stator and rotor are clean and dry.
- Check the frame for cracks in the metal or cracks in the paint that might indicate that the metal has been stressed beyond it's safe limits. Replace or get properly re-welded as necessary.
- Check the spokes for tightness and adjust if necessary.
- Check the rims and hubs for signs of stress, like cracks around the rim, spokes and hub.
- Every 2 hours of operation
 - Replace the transmission oil.
 - Check spoke tension
- Every 10 hours of operation
 - Replace the fork oil.
 - Have the shock oil replaced by a Certified Cobra Mechanic.

CAUTION:

If you ever need to weld anything on the bike, disconnect the spark plug cap, unplug the ignition, disconnect the kill switch, scrape the paint bare near the area to be welded and put the ground clamp as close to the area to be welded as possible.

⚠ WARNING

Be sure the fuel tank and carburetor have been removed and safely located away from the welding process.

The frame is a combination of HSLA steel and 4130 Chrome Moly and it is important to weld it with the proper rod and heat settings set as light as possible. Cobra recommends replacing the frame with a new one if the old one becomes damaged. Use ER70S6 filler if welding on the frame.

Replacing Transmission / Clutch Lubricant

Tools needed:

- 18 oz, of high quality transmission oil, or Cobra clutch milk
- 8 mm Allen wrench

CAUTION:

General automotive motor oil has frictional modifiers which will cause premature wear and failure of the clutch.

Procedure:

1. Begin this procedure with a bike that has been ridden more than 5 minutes but less than 10 minutes. It is desired to have the engine warm enough so that the oil is 'runny' but not so hot that there is risk of being burned by the engine or the oil.

⚠ WARNING

Hot oil and hot components on the motorcycle may cause burns.

2. Lean the bike against something or set on stand with oil drain hole.
3. Using a 8mm Allen wrench, remove the oil drain bolt located on the right side of the engine, on the clutch cover, near the brake lever (See Figure 1).

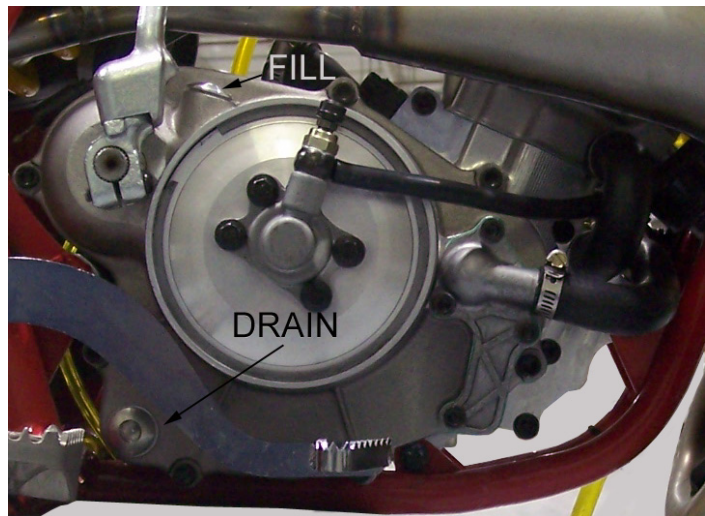

Figure 1.

NOTE: You may need to adjust the brake pedal (up or down) to gain access to the drain bolt.

4. After it has drained, reinstall the bolt being sure that the rubber gasket is in place. Torque to 11 Nm (8 ft-lb).
5. Remove oil fill plug with an 8mm Allen wrench.
6. Carefully pour 16 oz (470 ml) of transmission oil into the oil fill opening.
7. Reinstall the oil fill plug making sure the rubber gasket is in place.

NOTE: Filling after an engine rebuild required additional transmission fluid. If the engine is completely flushed of oil, refill with 18 oz (530ml).

⚠ WARNING

Always capture and dispose of used oil properly (all auto parts stores accept used oil). Dumping oil on the ground is illegal, inconsiderate, and can get you disqualified from a race weekend quicker than cutting the track.

Chain adjustment

Tools required for chain adjustment

- 22 mm wrench or socket
- 2 - 11 mm open-end wrenches

1. Make sure that the rear wheel is aligned properly.
2. For proper adjustment, the chain should have 35 mm free movement just behind the chain block with no load on the bike (Figure 2)



Figure 2.

CAUTION:

Sit on the bike and verify that the chain has a minimum of 12mm (1/2") free movement when the chain is at its tightest point.

3. If the chain requires adjusting, loosen the axle with a 22mm wrench, and loosen the jam nut with an 11mm wrench. Tighten the chain by rotating the adjuster bolts clockwise (CW) or loosen the chain by rotating the adjuster bolts (CCW).
4. Put a rag between the sprocket and chain, and roll the wheel backward to pull the chain adjuster blocks tightly against the adjuster bolts (Figure 3).
5. Retighten the axle bolt to 25 ft-lb (34 Nm).
6. Retighten the adjuster jam nuts.



Figure 3.

CAUTION:

Always check rear brake adjustment and free-play after adjusting the chain.

Air Filter Cleaning

Tools recommended for air filter maintenance:

- 4 mm hex key (Allen)
- Foam filter oil

Procedure

1. Removed seat with the 4mm hex key.
2. Unhook the air filter wire from its perch
3. Carefully remove the air filter and frame out the top of the airbox making sure not to dislodge any dirt into the intake tract.
4. Clean the filter in a nonflammable solvent to remove the filter oil.



Figure 4.

⚠ WARNING

Do not clean the air filter with gasoline or other highly volatile petroleum product. Diesel fuel, mineral spirits, or kerosene would be preferred but caution should still be taken.

5. Clean the filter in hot soapy water to remove all dirt particles.
6. Allow it to dry thoroughly.
7. Saturate with filter oil and remove excess.

NOTE:

It is very important to keep the air filter clean and properly oiled with high quality water-resistant foam filter oil. Apply oil consistently because varied amounts of oil will affect carburetor jetting.

8. **Reinstall** the filter assembly by pushing it down and forward into the airbox making sure the lip of the filter cage is properly seated into its receptacle (figure 5). Reinstall the air filter cap and holding wire.



Figure 5.

CAUTION:

Double check to insure that the filter is pushed in tight at the bottom

NOTE:

Make sure you change or clean your filter after each moto. We recommend carrying multiple filters in your toolbox, one for each practice session and moto.

Fork Oil Replacement

Requirements

- 19mm and 27mm combination wrench
- 6mm and 10mm hex key (Allen)
- Flexible retrieving tool
- 10w fork oil (approximately 210cc per fork leg)

Disassembly

1. Remove the front wheel and front brake caliper.
2. Remove the fork legs from the triple clamps.
3. Perform the following on each fork leg:
 - a. Remove the fork cap from the fork tube using a 27mm wrench.
 - b. Lower the fork tube to expose the fork spring.
 - c. Pull the fork spring down from the fork cap to expose the damper rod lock nut. Secure this nut using a 19mm wrench.
 - d. With a 19mm wrench on the damper rod nut, use a 27mm wrench to free the fork cap from the damper rod.
 - e. Remove the 19mm wrench and allow the damper rod to fall into the damper tube.
 - f. Remove the fork spring and spacer.
 - g. Invert the fork to allow the oil to drain. Pump the damper rod assembly several times to help the oil drain.

Assembly

1. Completely collapse the outer fork tube onto the stanchion tube. Add enough oil to the fork to fill the cartridge tube. Pump the damper rod up and down slowly to help the assembly fill with oil.
2. Once the cartridge assembly is bled, continue to fill the fork with oil until it is 120mm +/- 2.5mm from the top of the fork.
3. Install the fork spring.
4. Use a flexible retrieving tool to pull the damper rod up through the fork spring. Pull the fork spring down from the damper rod to expose the damper rod lock nut. Secure this nut using a 19mm wrench.
5. Install the spacer and fork cap to the damper rod. Ensure that the fork cap is completely threaded onto the damper rod before it makes contact with the lock nut. Torque the damper rod lock nut to 15N-m (11ft-lb).
6. Install the fork cap to the fork tube. Torque the fork cap to 20Nm (15ft-lb).
7. Pump the fork leg several times to verify that it operates smoothly.
8. Install each leg back into the triple clamp. Torque each pinch bolt to 11N-m (8 ft-lb) making sure both legs are set to the same height in the clamps.
9. Install the front wheel, and torque the axle to 13.5N-m (10 ft-lb).
10. Drop the bike onto the ground, engage the front brake, and push up and down on the handlebars several time to ensure that the front forks and the front wheel are properly aligned with each other.
11. Tighten the axle pinch bolts to 10N-m (7.4 ft-lb).

Ignition Timing

The ignition timing value for the 2009 CX65 is 5° retarded from the standard base reference (0°). This can be verified by removing the ignition cover and looking as shown in the figure below.

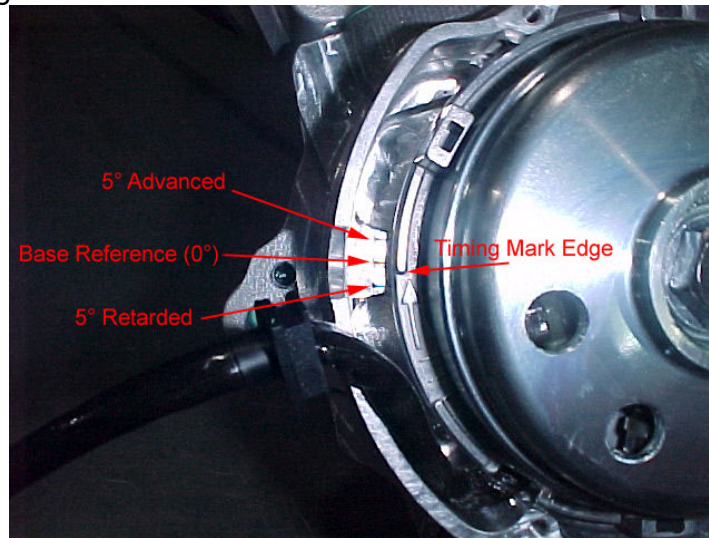

The center mark on the cases is the standard base reference timing mark (0°), and the other two large marks are 5° advanced and retarded. The small timing marks between 0 & 5° is 2.5°.

To change the timing, one must remove the flywheel with Cobra 65 flywheel puller # MCMUTL05. After the flywheel has been removed, the timing can be adjusted by loosening the stator bolts and rotating the stator to the desired position.

Parts

Parts – Airbox & Inlet System

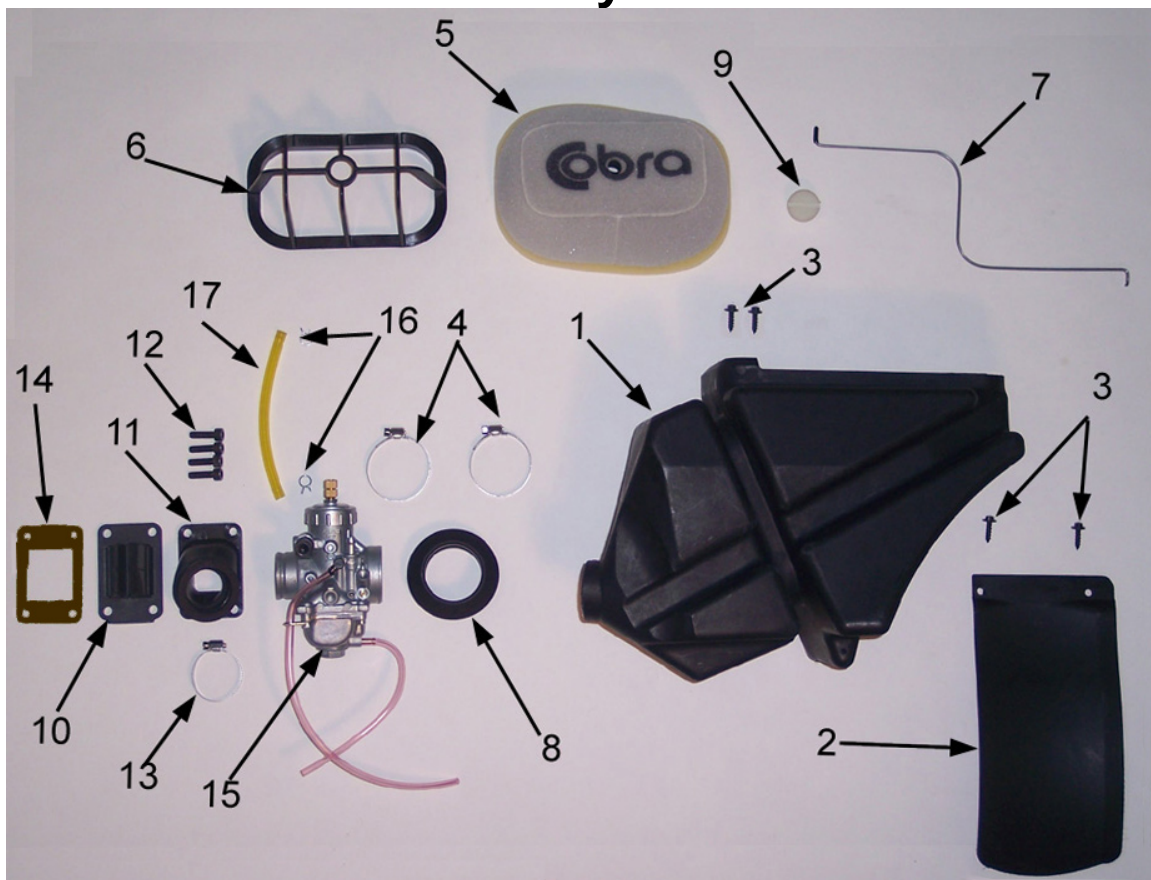

Coolant System		
REF #	PART #	DESCRIPTION
1	RCC60007	AIRBOX 07 65
2	TCC60008	MUD FLAP 07 65
3	HCSP0003	SCREW - PLASCREW
4	MCKGHO03	CLAMP, AIR BOOT TO AIR BOX
5	RCC60002	AIR FILTER 07 65
6	RCC60003	AIR FILTER CAGE
7	RCC60004	AIR FILTER WIRE 07 65
8	RCC60014	AIR BOOT, CARB TO AIRBOX 65
9	RCC60006	AIR FILTER CAP 07 65
10	ECC60006	REED ASSEMBLY 07 65
NOT SHOWN	ECC60014	REED PEDALS - REPLACEMENT
11	ECC60007	INLET MANIFOLD 07 65
12	HCBC0602	6X20MM SOCKET HEAD CAP SCREW
13	MCC60003	CLAMP, MANIFOLD TO CARB
14	ZCC60021	GASKET REED 07 65
15	RCC60001	CARBURETOR 24MM MIKUNI
16	MCMUCL04	HOSE CLAMP 8MM
17	FCMU0026	FUEL LINE

Parts - Carburetor

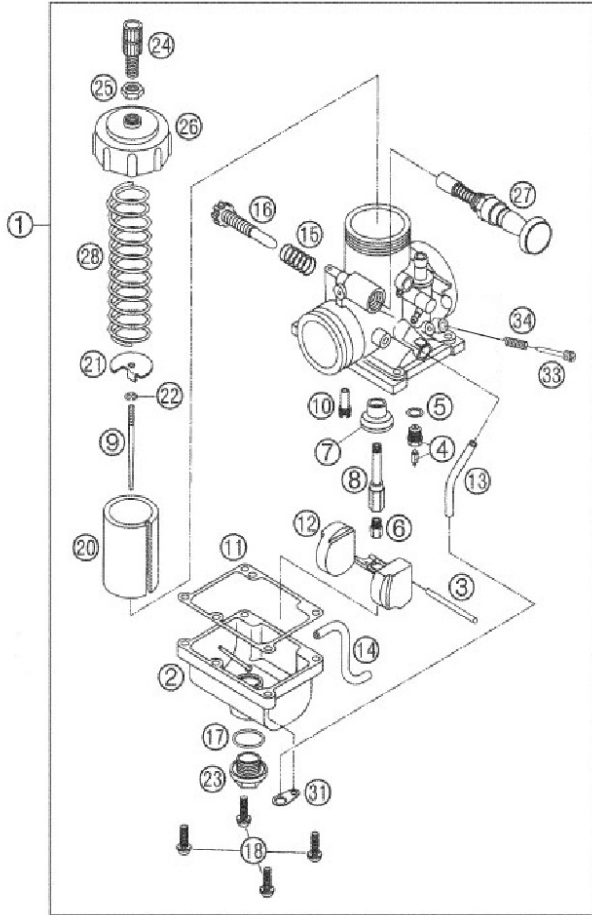

Carburetor		
REF. #	PART #	DESCRIPTION
1	RAR6028	CARBURETOR 28MM KEIHIN
2		
3		
4		
5		
6	SEE BELOW	MAIN JET
8		
9		
10	SEE BELOW	PILOT JET
11	RCC60013	GASKET , FLOAT BOWL
12		
13		
15		
16		
17		
18		
20		
21		
22		
23		
24		
	RCMU0415	CABLE ADJUSTER CAP
25		
26		
27		
31		
33		
34		

PILOT JET		MAIN JET	
22.5	RCEX0022	165	RCMU0165
25	RCEX0025	170	RCMU0170
27.5	RCEX0027	175	RCMU0175
30	RCEX0030	180	RCMU0180
32.5	RCEX0032	185	RCMU0185
35	RCEX0035	190	RCMU0190
37.5	RCEX0037	195	RCMU0195
40	RCEX0040	200	RCMU0200
42.5	RCEX0042	205	RCMU0205
45	RCEX0045	210	RCMU0210
47.5	RCEX0047	215	RCMU0215
50	RCEX0050	220	RCMU0220
52.5	RCEX0052	225	
55	RCEX0055	230	RCMU0230
57.5	RCEX0057	235	RCMU0235
60	RCEX0060	240	RCMU0240
65	RCEX0065	245	RCMU0245
70	RCEX0070	250	RCMU1250

Parts – Clutch Actuation

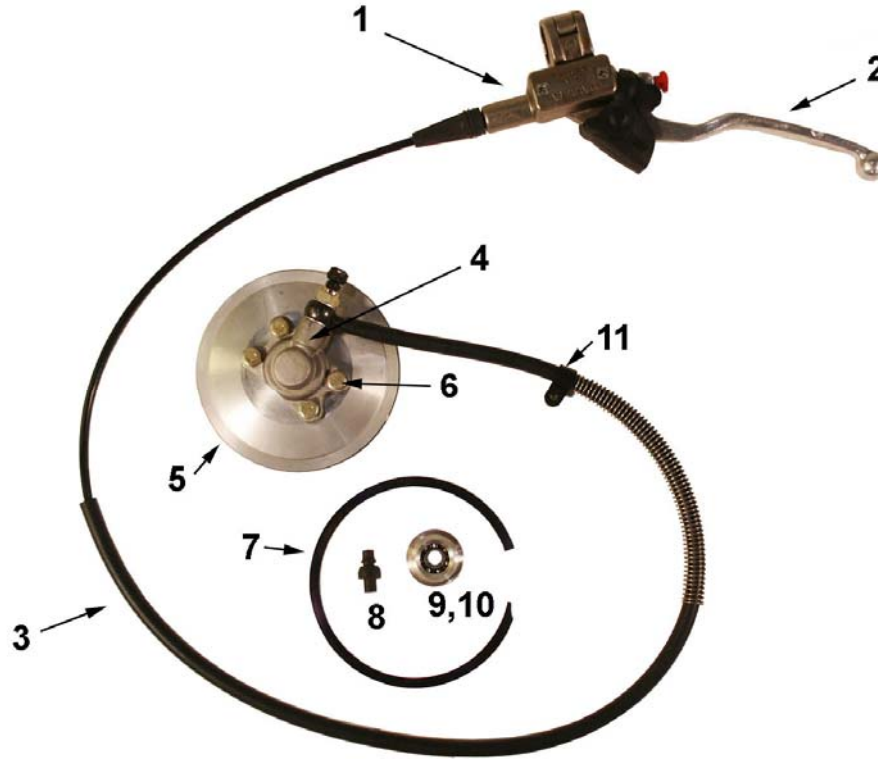

Clutch Actuation		
REF #	PART #	DESCRIPTION
1	CCMU0004	MASTER CYLINDER
2	CCDC0001	CLUTCH LEVER
NOT SHOWN	CCMU0035	COVER – RESERVOIR (REPLACEMENT)
NOT SHOWN	CCMU0036	CLAMP – PERCH (REPLACEMENT)
3	CAC60001	CLUTCH ACUTATOR ASSEMBLY (Lever, Master Cyl., Line, Slave Cyl.)
NOT SHOWN	CCC60001	CLUTCH LINE ONLY
4	CCDC0002	CLUTCH SLAVE CYLINDER
5	ECDC0074	CLUTCH CAP
6	HCBC0601	6X16 SOCKET HEAD CAP SCREW (4 REQ'D)
7	ECDC0082	SNAP RING – CLUTCH CAP
8	ECDC0020	CLUTCH PUSH ROD
9	ECDC0018	CLUTCH THROW-OUT BEARING
10	ECDC0019	CLUTCH BEARING SEAT
11	HCCC0002	CABLE CLAMP
NOT SHOWN	ZCDCOR05	CLUTCH CAP O-RING
NOT SHOWN	ZCDCOR04	SLAVE CYLINDER O-RING

Parts – Coolant System

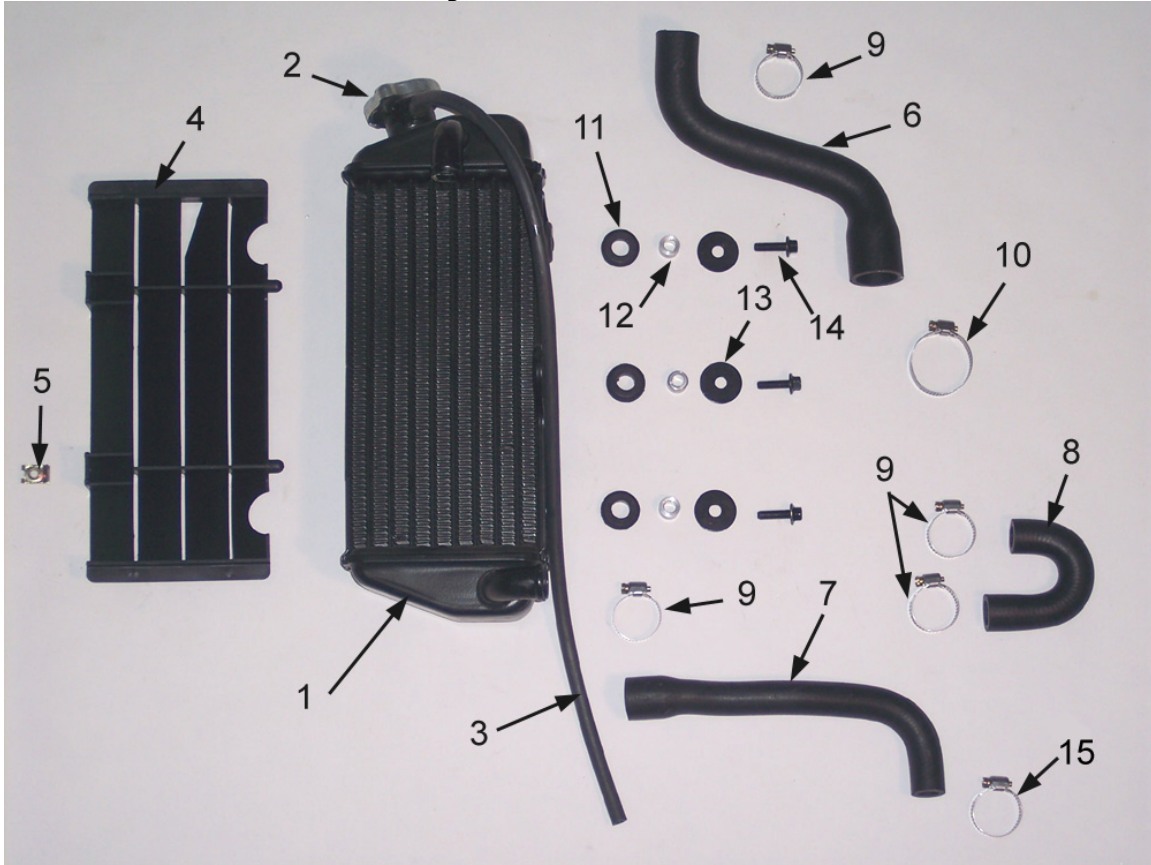

Coolant System		
REF #	PART #	DESCRIPTION
1	FCDC0000	RADIATOR W/CAP - CX65
2	FCMU0047	CAP - RADIATOR
3	FCKG0214	HOSE - OVERFLOW
	MCMUCL05	HOSE CLAMP 11-20 UNIVERSAL
4	FCDC0009	RADIATOR LOUVER-CX65
NOT SHOWN	HCSP0002	PUSH PIN - PLASTIC
5	HCCN0000	5MM EXTRUDED "U" NUT
6	ECC60011	HOSE RADIATOR UPPER
7	ECC60012	HOSE RADIATOR BOTTOM
8	ECC60013	HOSE TRANSFER - CASES TO CYLINDER
9	MCMUCL07	HOSE CLAMP RADIATOR MEDIUM (4 REQ'D)
10	MCKGHO04	HOSE CLAMP RADIATOR LARGE (1 REQ'D)
11	MCEXGR01	GROMMET RADIATOR
12	WCMU0006	SPACER
13	HCWF1478	6MM WASHER 22MM OD BLK ZINC
14	HCBF0625	6X25 FLANGED HEX-8MM HEAD
15	MCMUCL09	HOSE CLAMP RADIATOR SMALL (1 REQ'D)

Parts – Electrical System

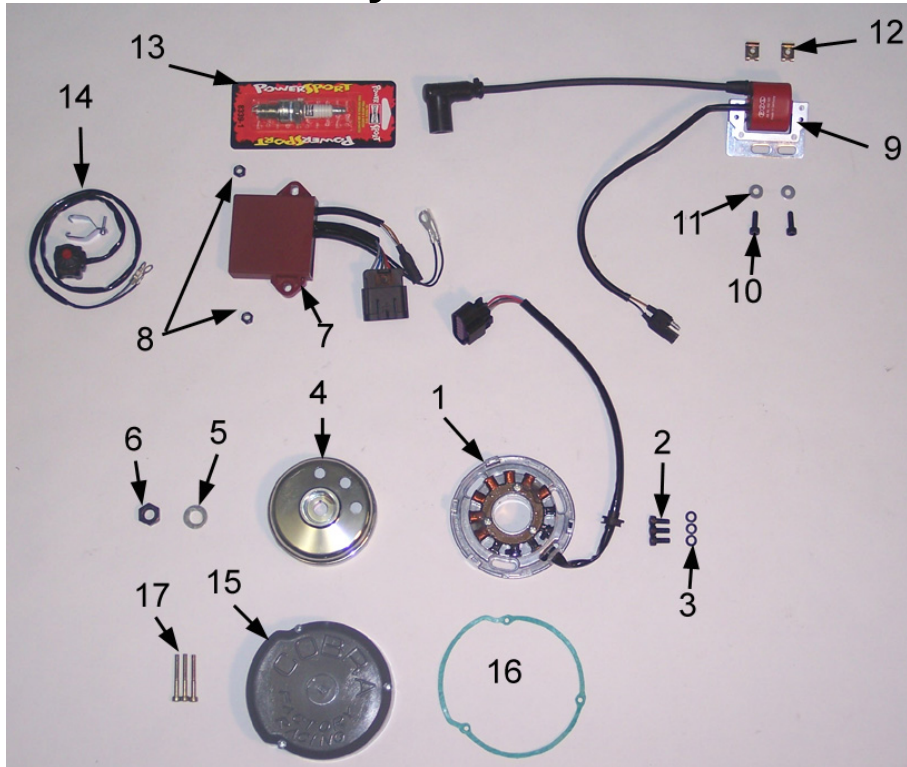

Electrical System		
REF #	PART #	DESCRIPTION
1	ICC60004	STATOR DIGITAL 07 65
2	HCBB0516	5X12MM SHCS (3 REQ'D)
3	HCWF0501	5MM FLAT WASHER (3 REQ'D)
4	ICC60003	ROTOR OUTER STYLE 07 65
	ICMU0012	WOODRUFF KEY
5	HCWF0010	10MM FLAT WASHER
6	HCNS1001	10MM X 1.25 NUT
7	ICC60002	CDI UNIT 07 65
8	HCNL0601	6MM LOCKNUT – CDI MOUNTING (2 REQ'D)
9	ICC60001	COIL DIGITAL 07 65
10	HCBC0516	5X16MM SHCS – COIL MOUNTING (2REQ'D)
11	HCSP0002	5MM WASHER – COIL MOUNTING (2 REQ'D)
12	HCCN0000	5MM EXTRUDED "U" NUT – COIL MOUNTING (2 REQ'D)
13	ECMU0065	SPARK PLUG, CHAMPION (8339-1)
	ECMU0067	OPTIONAL HOTTER PLUG (8332-1)
	ECMU0066	OPTIONAL COLDER PLUG (8904-1)
14	FCMU0033	KILL SWITCH ASSEMBLY
15	ECDC0085	COVER - IGNITION
16	ZCDC0004	GASKET-IGNITION COVER – may not be used on CARD bike
17	HCBC0401	4X25MM SHCS – COVER MOUNTING (3 REQ'D)



Parts – Engine Clutch

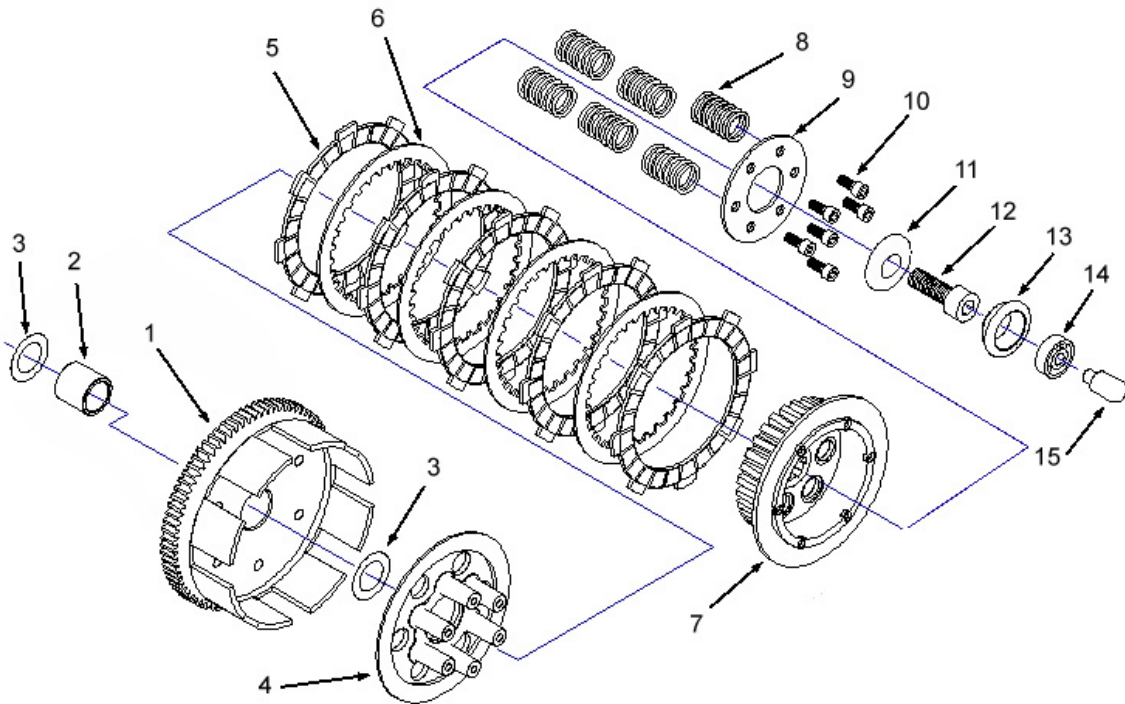

Clutch components		
REF. #	PART #	DESCRIPTION
1	ESEX0003	CLUTCH BASKET ASSEMBLY
2	ECDC0064	CLUTCH BUSHING – INNER / STEEL
NOT SHOWN	ECDC0167	CLUTCH BUSHING - OUTER / BRONZE
3	ECDC0063	CLUTCH WASHER (2 PLACES)
4	ECDC0066	CLUTCH PRESSURE PLATE
5	ECDC0068	CLUTCH DISC-FRICTION – (5 REQ'D)
6	ECDC0067	CLUTCH DISC-STEEL – (4 REQ'D)
7	ECDC0069	CLUTCH HUB
8	ECDC0070	SPRING, CLUTCH – (6 REQ'D)
9	ECMU0224	PLATE, CLUTCH SPRING
10	HCBC0525	5X25 SOCKET HEAD CAP SCREW (6 REQ'D)
11	ECDC0030	SPRING WASHER – CLUTCH
12	HCBC1035	10MM X 35 SHCS BLACK OXIDE
13	ECDC0019	CLUTCH BEARING SEAT
14	ECDC0018	BEARING,CLUTCH THROW OUT
15	ECDC0020	CLUTCH PUSH ROD

Parts – Engine – Clutch / Kick Cover

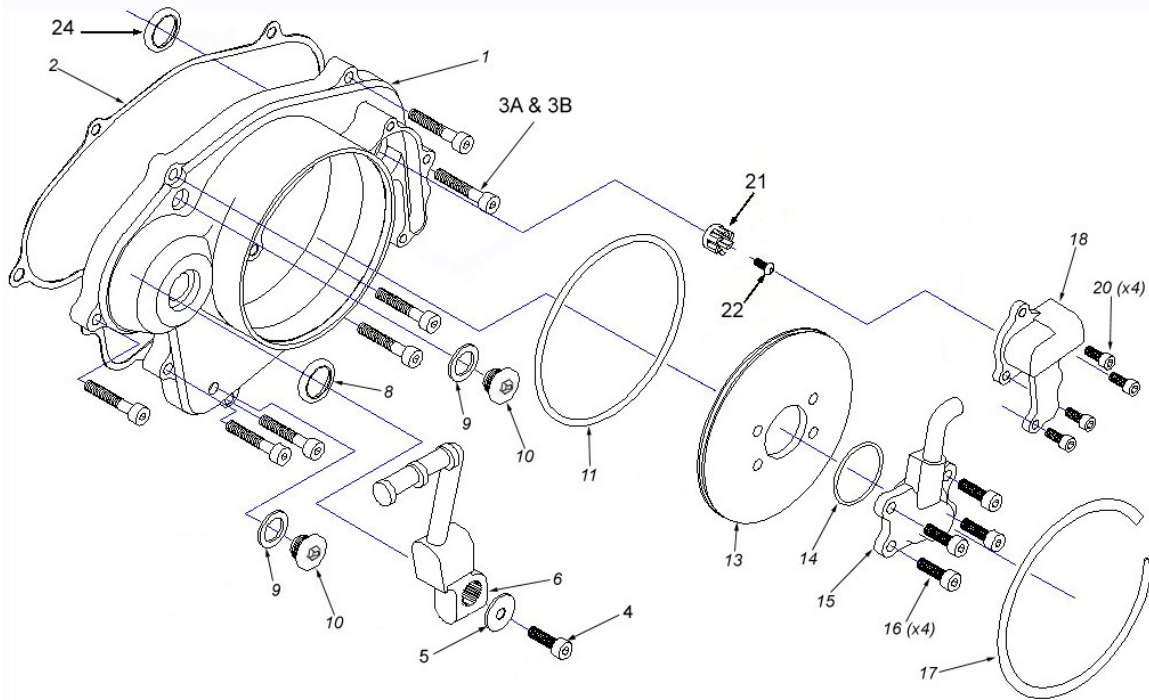

Clutch / kick cover components		
REF. #	PART #	DESCRIPTION
1	ECMU0150	CLUTCH COVER (07 STYLE)
2	ZCMU0014	GASKET-CLUTCHCOVER
3A	HCBF0625	6X25 SOCKET HEAD CAP SCREW (6 REQ'D)
3B	HCBF0630	6X30 SOCKET HEAD CAP SCREW (2 REQ'D)
4	HCBF0612	6X12 FLANGE HEAD BOLT
5	HCWF0618	WASHER - KICK LEVER
6	ECMU0130	KICKSTARTER LEVER
8	ECDC0078	SEAL,KICKSTARTER
9	ZCMUB014	O'RING-OIL FILL PLUG
10	ECMU0168 (B, BL, OR R)	OIL FILL PLUG, ALUMINUM (SUFFIX INDICATES COLOR, B - BLACK, BL - BLUE, R - RED)
11	ZCDCOR05	ORING-CLUTCH CAP
13	ECDC0074	CLUTCH CAP
14	ZCDCOR04	ORING,CLUTCH SLAVE CYLINDER
NOT SHOWN	CCEX0009	BALL, CLUTCH ACTUATOR
15	CAC60001	CLUTCH ASSEMBLY
16	HCBC0601	6X16 SOCKET HEAD CAP SCREW (4 REQ'D)
17	ECDC0082	SNAP RING-CLUTCH CAP
18	ECAX0150	IMPELLER COVER
	ZCC60004	GASKET-IMPELLER COVER (may not be used)
20	HCBC0601	6X16 SOCKET HEAD CAP SCREW
21	ECDC0075	IMPELLER, WATERPUMP
22	HCBC0601	6X16 SHCS
24	ECKG0074	SEAL, WATERPUMP
NOT SHOWN	ECMU0218	RETAINING RING, WATER PUMP SEAL

Parts - Engine - Ignition Side

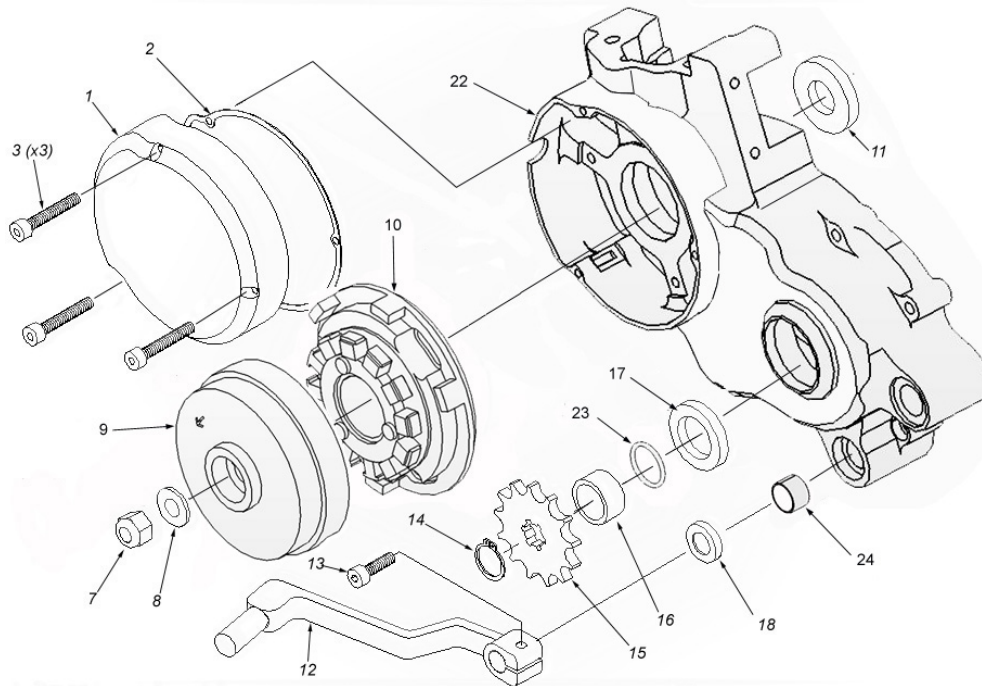

Ignition side engine components		
REF. #	PART #	DESCRIPTION
1	ECDC0085	IGNITION COVER
2	ZCDC0004	GASKET-IGNITION COVER (may not be used on CARD bike)
3	HCBC0401	4X25 SOCKET HEAD CAP SCREW (3 REQ'D)
4	HCBC0501	5X12MM SHCS
6	HCWF0501	WASHER FLAT 5MM
7	HCNS1001	NUT M10
8	HCWF0010	10MM FLAT WASHER
9	ICC60003	ROTOR PVL OUTER STYLE
10	ICC60004	STATOR PVL DIGITAL 07 65
11	ECDC0024	SEAL, CRANKSHAFT
12	ECDC0086	SHIFTER LEVER - CX65
13	HCFH0620	M6 X 20 HEX HEAD BOLT
14	ECKGSR03	SNAP RING-OUTPUT-COBRA
15	PCKG00xx	SPROCKET xx denotes number of teeth
16	ECDC0009	SPACER, SPROCKET
17	ECDC0025	SEAL, OUTPUT
18	ECDC0026	SEAL, SHIFTER
21	ICMUGR01	GROMMET-IGNITION
22	EKR62009	ENGINE CASE SET W/B&S CX65 09
23	ZCDCOR01	O-RING, SPROCKET SPACER
24	ECEX0008	BUSHING, SHIFTER SHAFT
NOT SHOWN	ECR60010	HOSE HOLDER

Parts - Engine – Kick Mechanism

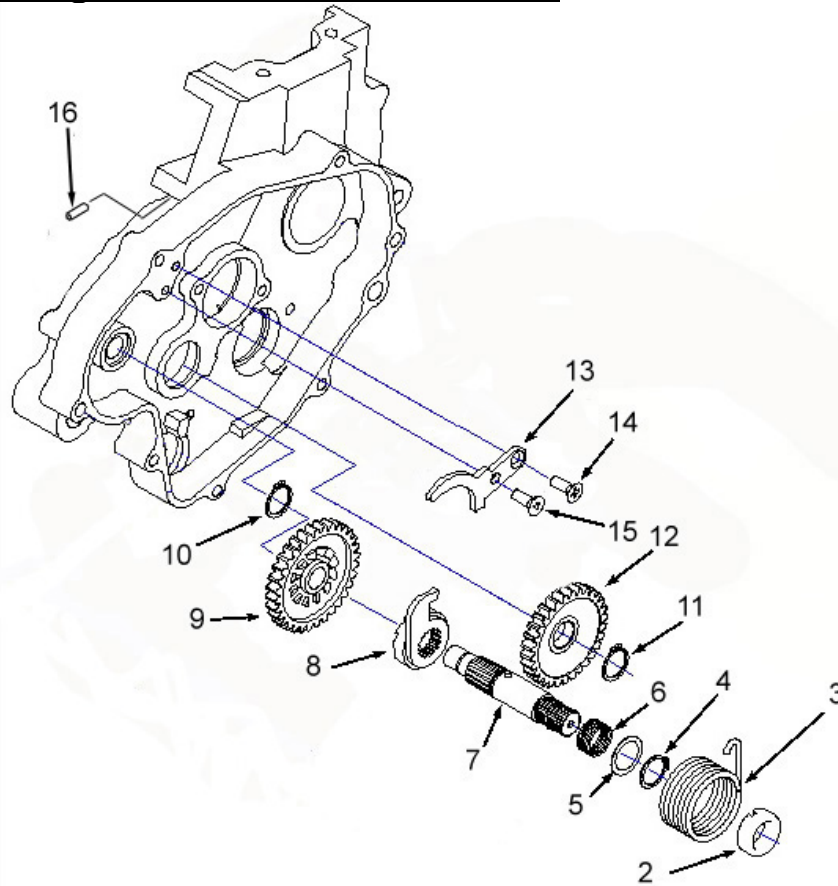

Kick Mechanism		
REF. #	PART #	DESCRIPTION
	EKR62009	ENGINE CASE SET W/B&S CX65 09
2	ECDC0111	SPACER, KICK START SHAFT
3	ECDC0040	SPRING, KICKSTART RETURN
4	ECDC0036	SNAP RING, EXTERNAL 16MM
5	ECDC0043	WASHER, KICKSTART BACKUP
6	ECDC0042	SPRING, KICKSTART RAMP
7	ECMU0135	SHAFT, KICK START
8	ECDC0038	RAMP GEAR, KICKSTART
9	ECDC0033	GEAR, KICKSTART
10	ECDC0035	SNAP RING, EXTERNAL 12MM
11	ECDC0037	SNAP RING, EXTERNAL 15MM
12	ECDC0032	GEAR, KICK START IDLE
13	ECDC0039	RAMP, KICK START
14	ECDC0060	6MM X 16 PHILLIPS FLAT HEAD SCREW
15	HCBB1612	6MM X 12 MM BUTTON HEAD BLACK OXIDE
16	ECMU0533	FITTING, VENT HOSE
NOT SHOWN	ECMU0534	VENT HOSE

Parts – Engine – Shift Mechanism

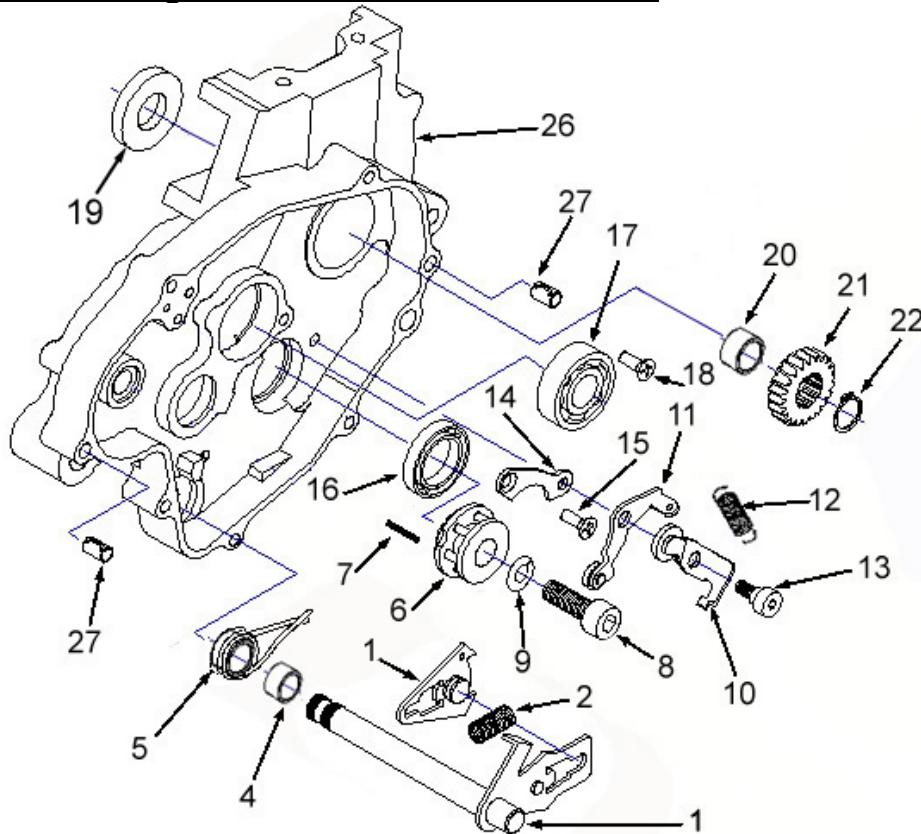

Clutch components		
REF. #	PART #	DESCRIPTION
1	EADC0154	SHIFTER SHAFT (2 COMPONENTS) W/SPRING
2	ECDC0055	SPRING - SHIFTER SHAFT
4	ECDC0110	SPACER, CENTERING SPRING
5	ECDC0099	SPRING, CENTERING
6	ECMU0550	SHIFT CASSETTE (W/O PINS)
7	ECDC0051	DOWEL – SHIFT DRUM INDEX
8	HCBC1825	8MM X 25 SHCS BLACK OXIDE
9	HCWL0802	8MM LOCKWASHER, HI COLLAR
10	ECMU0548	PIVOT, SHIFT ARM
11	ECMU0546	SPRING, SHIFT FOLLOWER ARM
12	ECMU0545	ARM ASSY, SHIFT FOLLOWER
13	ECDC0035	CLIP, ARM RETAINER
14	ECDC0056	BEARING RETAINER PLATE
15	ECDC0060	6MM X 16 FLAT HEAD PHILLIPS SCREW
16	ECDC0022	BEARING, SHIFT DRUM
17	ECMU0216	BEARING, PRIMARY SHAFT CLUTCH SIDE
18	HCBB1612	6MM X 12 BUTTON HEAD BLACK OXIDE
19	ECDC0024	SEAL, CRANKSHAFT
20	ECDC0112	SPACER, CRANK DRIVE GEAR
21	ECDC0073	CRANK DRIVE GEAR
22	ECDC0036	SNAP RING, EXT 16MM
26	EKR62009	ENGINE CASE SET W/B&S CX65 09
27	ECDC0031	DOWEL, HOLLOW (2 PLACES)
28	HCBB1612	6MM X 12 BUTTON HEAD

Parts – Engine – Top End

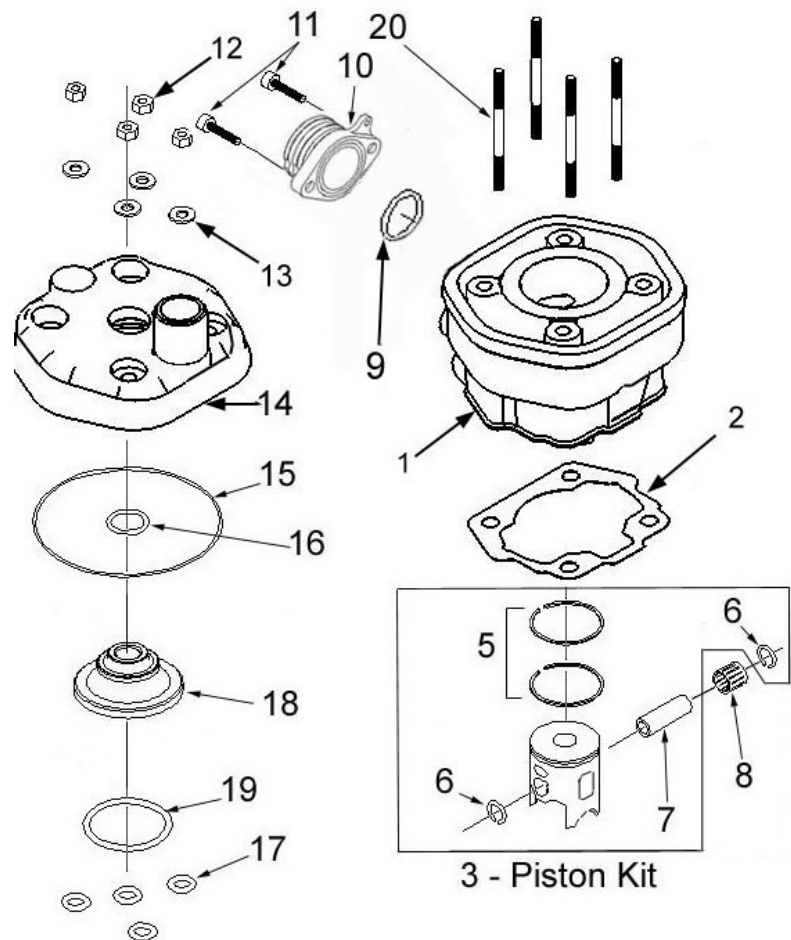

Engine – Top End		
REF #	PART #	DESCRIPTION
1	ECC60017	CYLINDER KIT (INCLUDES PISTON KIT)
2	ZCC60115	BASE GASKET 0.015" (0.4mm thick) For other Base Gaskets refer to Base Gasket Selection section of this manual (PG 37) More than one gasket may be required!
3	ECMU0184xx	PISTON KIT (xx denotes piston size, A, or AB, etc...)
5	ECX0005	PISTON RINGS (2 PER SET)
6	**	SNAP RING FOR PISTON (2 REQ'D)
7	**	WRIST PIN
8	ECDC0061	BEARING, WRIST PIN
9	ZCMUOR07	O-RING, EXHAUST FLANGE
10	ECC60002	EXHAUST FLANGE 30MM
NOT SHOWN	ZCMOTE11	O-RINGS – PIPE TO FLANGE (2 REQ'D)
11	HCBC0601	M6X16 SHCS, EXHAUST FLANGE SCREW (2 REQ'D)
12	HCNS0703	7MM NUT TALL
13	HCWS1401	FLAT WASHER – HARDENED
14	ECC60010	CYLINDER HEAD OUTER
	ECMU0168R	PLUG COOLANG IN CYLINDER HEAD
15	ZCMUOR02	O-RING, CYLINDER HEAD LARGE
16	ZCMUV024	O-RING CYLINDER HEAD SMALL
17	ZCMUOR10	O-RING CYLINDER STUD (4 REQ'D)
18	ECRC0008	CYLINDER HEAD INSERT 09 65
19	ZCMUV032	O-RING CYLINDER HEAD MEDIUM
20	ECMU0147	STUD, CYLINDER 7mm

** Call Tech support if you need these parts.

Parts - Engine - Transmission

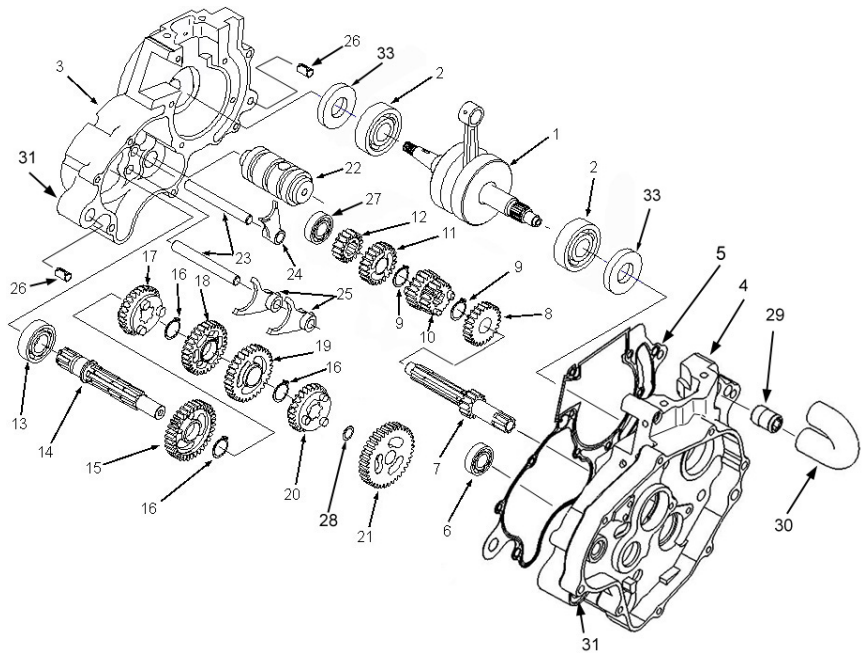

Transmission		
REF #	PART #	DESCRIPTION
1	ECC60027	CRANKSHAFT 09 65
2L	ECC60033	BEARING, ROLLER
2R	ECR60007	BEARING, CRANKSHAFT NSK
ACCESSORY	EKEX0001	ROD KIT
3	EKR62009	ENGINE CASE SET W/B&S CX65 09
4	EKR62009	ENGINE CASE SET W/B&S CX65 09
5	ZCC60003	GASKET CRANKCASE 09 65
Left Case Screws	HCBC0604	6X35MM SOCKET HEAD CAP SCREW (4 REQ'D)
Right Case Screws	HCBC0603	6X30MM SHCS (7 REQ'D)
Right Case Screws	HCBC0607	6X50 SHCS
6	ECDC0021	BEARING, OUTPUTSHAFT CLUTCH SIDE
7	ECDC0001	SHAFT, TRANSMISSION PRIMARY (1 ST GEAR), 13T
8	ECDC0002	GEAR, 6 TH PRIMARY 24T
9	ECDC0003	SNAP RING, EXTERNAL 17 MM (2 REQ'D)
10	ECDC0004	GEAR, 3 RD /4 TH PRIMARY, 18/21T
11	ECDC0005	GEAR, 5 TH PRIMARY, 23T
12	ECDC0006	GEAR, 2 ND PRIMARY, 16T
13	ECKGBR01	BEARING, OUTPUT IGNITION SIDE
14	ECDC0007	SHAFT, TRANSMISSION OUTPUT
15	ECDC0014	GEAR, 2 ND OUTPUT, 31T
16	ECDC0017	SHAP RING, EXTERNAL 18MM (3 REQ'D)
17	ECDC0013	GEAR, 5 TH , OUTPUT, 30T
18	ECDC0011	GEAR, 4 TH OUTPUT, 28T
19	ECDC0010	GEAR, 3 RD OUTPUT, 34T
20	ECDC0015	GEAR, 6 TH OUTPUT, 26T
21	ECDC0016	GEAR, 1 ST OUTPUT, 37T
22	ECDC0047	SHIFT DRUM
23	ECDC0050	SHIFT ROD (2 REQ'D)
24	ECDC0048	SHIFT FORK, INPUT
25	ECDC0049	SHIFT FORK, OUTPUT (2 REQ'D)
26	HCDP1401	DOWEL, SOLID CENTERING (2 REQ'D)
27	ECKG0031	BEARING, PRIMARY SHAFT IGNITION SIDE
28A	ECMU0040	SHIM TRANSMISSION 0.030" (0.48mm) THICK
28B	ECMU0040T	SHIM TRANSMISSION 0.015" (0.4 mm) THICK
31	ECC60015	BUSHING ENGINE / SWINGARM PIVOT CX65
32	ECMU0549	BEARING, NEEDLE, SHIFT DRUM LEFT SIDE

Parts – Exhaust System

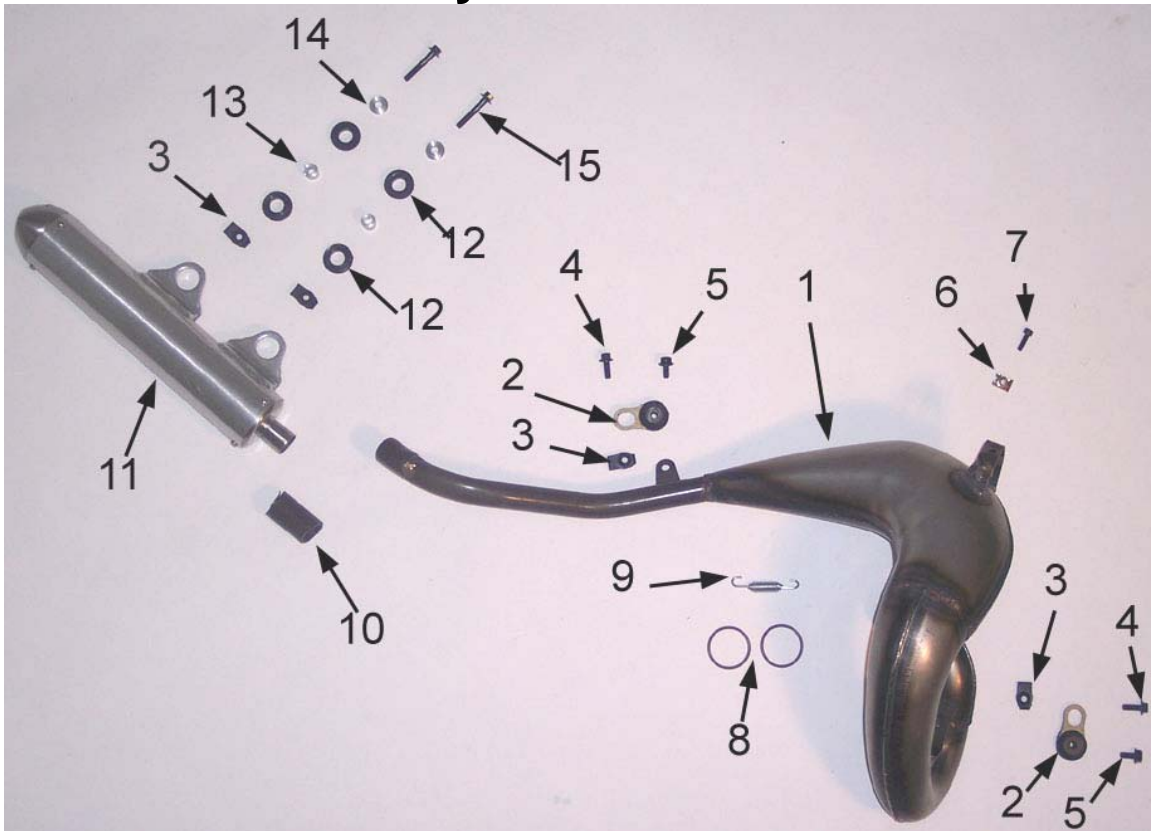

Exhaust System		
REF #	PART #	DESCRIPTION
1	XAR62009	EXPANSION CHAMBER 08
2	XCMU0033	ISOLATION MOUNT (2 REQ'D)
3	HCHA0003	6MM CLIP NUT-PLASTIC/PIPE MNT (2 REQ'D FOR PIPE & 2 REQ'D FOR SILENCER)
4	HCBF0616	6X16MM FLANGE HEAD BOLT (2 REQ'D)
5	HCBF0612	6X12MM FLANGE HEAD BOLT (2 REQ'D)
6	HCCN0000	5MM EXTRUDED "U" NUT
7	HCBC0516	5X16MM SHCS FOR RIGHT SHROUD MOUNT
8	ZCMOTE11	O-RING – EXHAUST (2 REQ'D)
9	XCMU0005	SPRING – PIPE – SHORT
10	XCKG0009	GROMMET – SILENCER TO PIPE
11	XCMU0032	SILENCER 10" ROUND 2007
12	MCMUGR03	GROMMET FOR RADIATOR (4 REQ'D)
13	TCKG0001	SPACER GENERAL ½DIA 13.2 LG (2 REQ'D)
14	TCC60016	SPACER TOP HAT (2 REQ'D)
15	HCBF0630	6X30 FLANGE HEX-8MM HEAD
NOT SHOWN	XCMU0026	SILENCER PACKING KIT

Parts – Forks – Leg Assembly

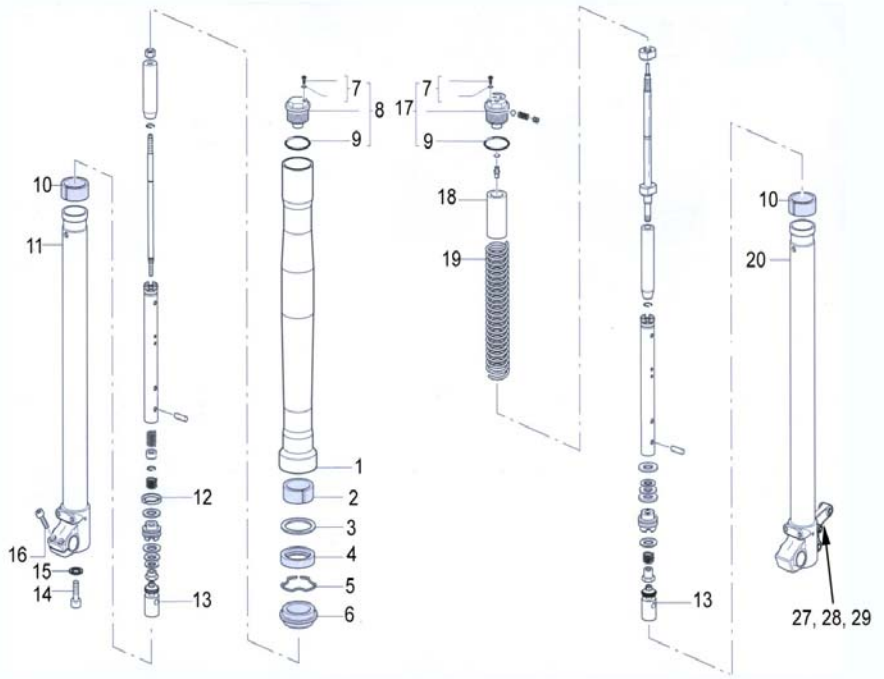
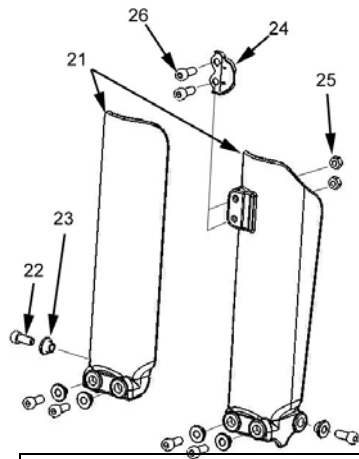

Fork Leg Assembly		
REF #	PART #	DESCRIPTION
	KACX6527	FORK SET – 2008 CX64
1		FORK LEG OUTER
2	KCC60004	BUSHING – TOP
3		WASHER
4	KCC60002	FORK SEAL
5	KCC60011	CLIP RING
6	KCC60003	DUST COVER (SWIPER)
7	KCC60012	BLEED SCREW WITH SEAL
8		CAP – REBOUND SIDE
9		O-RING – FORK CAP
10	KCC60005	BUSHING – BOTTOM
11		FORK LEG INNER – NON BRAKE SIDE
12	KCC60006	SEAL – PISTON
13	KCC60009	BASE VALVE BODY
14		BOLT – FORK BOTTOM
15	KCC60008	WASHER – FORK BOTTOM
16		BOLT – AXLE CLAMP
17	KCC60007	CAP - COMPRESSION SIDE
18		SPACER – PRELOAD
19	KCC60024	FORK SPRING .24 KG/MM
	KCC60026	FORK SPRING .26 KG/MM STANDARD
	KCC60028	FORK SPRING .28 KG/MM HEAVY
20		FORK LEG INNER – BRAKE SIDE
21	KCC60014	FORK GUARDS – PAIR (3 BOLT STYLE)
22	HCBC0601	6MM X 16 SHCS
23	KCC60019	SPACER – FORK GUARD MOUNTING
24	BCC60015	CLAMP – BRAKE LINE
25	HCNS0601	6MM NUT
26	HCBC0612	6MM X 12 SHCS
27	BCC60013	BRAKE BRACKET
28	HCBC0820	8X20MM SHCS
29	HCBC0812	8X12MM SHCS LOW HEAD

Parts – Frame & Triple Clamps

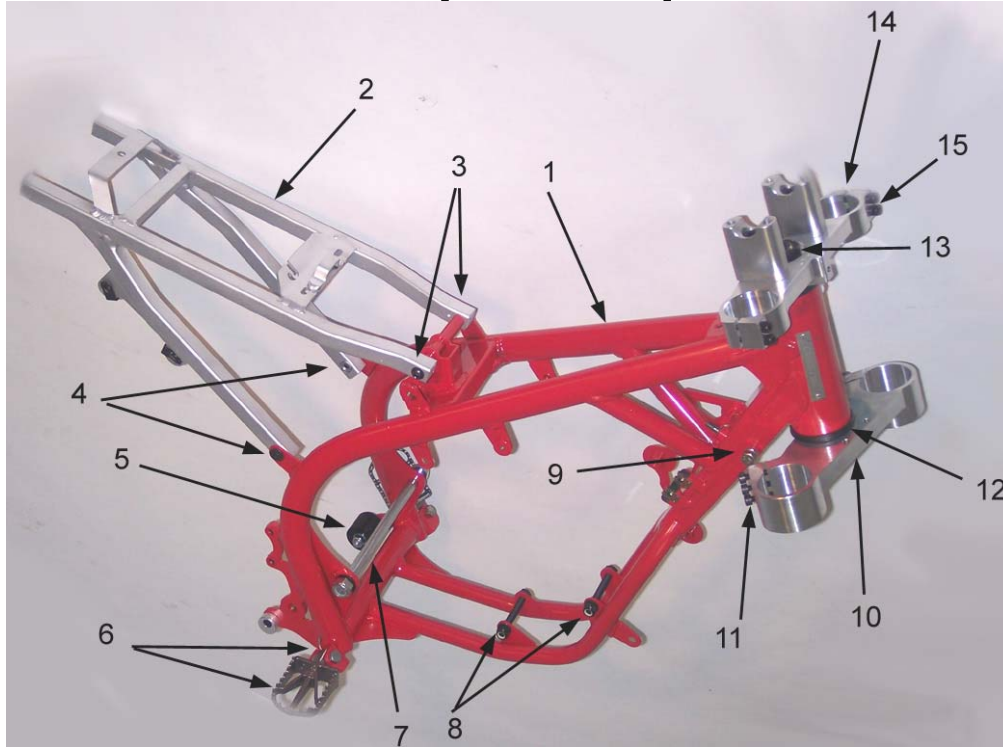

Frame		
REF #	PART #	DESCRIPTION
1	FAR60001	FRAME WELDED ASSEMBLY 07 65
2	FAC60002	SUBFRAME CX65 W/ BEARING RACES
3	HCBB0835	8X35MM BUTTON HEAD SCREW (2 REQ'D) – TOP MOUNT
4	HCFH0825	8X25MM FLAT HEAD CAP SCREW – (2 REQ'D) – BOTTOM MOUNT
5	FCC60020	CHAIN ROLLER W BEAR & SEALS
	BCDC0153	WASHER
6	TCMU0039	FOOTPEG SET ULTRA WIDE CX65
	TCC60012	FOOTPEG SPRING ULTRA WIDE 07 (2 REQ'D)
	HCBH0840	8MM X 40 HEX HEAD 30MM NO THRD – FOOTPEG (2 REQ'D)
	HCWF0803	
	HCNL0802	8MM LOCKNUT – FOOTPEG (2 REQ'D)
7	WCKG0011	SWINGARM PIVOT BOLT
	HCWF1202	12MM FLAT WASHER
	HCNL1201	12MM LOCKNUT
8	HCBH0865	8X65MM HEX HEAD – FRONT ENGINE MOUNTS (2 REQ'D)
	HCWF0801	8MM FLAT WASHER – FRONT ENGINE MOUNTS (4 REQ'D)
	HCNL0801	8MM LOCKNUT – FRONT ENGINE MOUNTS (2 REQ'D)
9	HCBH0807	8X20MM HEX HEAD – STEERING STOP (2 REQ'D)
	HCNS0801	8MM NUT – STEERING STOP (2 REQ'D)
10	FAC60001	TRIPLE CLAMP BOTTOM W/STEM
	FCMU0001	STEERING STEM
11	HCBC0625	6X25MM FOR BOTTOM CLAMP (6 REQ'D)
12	FCMU1103	DUST COVER STEER STEM, RUBBER (2 REQ'D)
	FCMU0004	BEARING – STEERING TAPERED
	FCMU0011	RACE – STEERING BEARING
13	HCNJ0102	JAM NUT STEERING STEM (2 REQ'D)
14	FCC60002	TRIPLE CLAMP TOP
15	HCBC0603	6X13MM SHCS FOR TOP CLAMP (4 REQ'D)

Parts – Front Wheel & Brakes



Front Brakes		
REF#	PART #	DESCRIPTION
1	WAC6FR01B	WHEEL 14" FRONT W BEARINGS (NO TIRE, OR TUBE,) BLACK
	WCC6F014B	TIRE-BRDGESTNE-60/100-14M39
	WCC6F014D	TIRE-DUNLOP-60/100-14 756
	WCDCHB01	HUB FOR CX65 – FRONT
	WCMU1400B	14" RIM, BLACK
	WCDCTU14	TUBE – 60/100-14 FRONT
	WCDC0009	RIM LINER 14" WHEEL
	WCDC0002	SPOKE-FRONT WHEEL-65
	WCDC0011	NIPPLE-SPOKE 9GA. STAINLESS
2	WCC60008	AXLE FRONT 07 65 STEEL
NOT SHOWN	HCNL1402	NUT, FRONT AXLE
3	WCMU0120	BEARING, WHEEL-SEALED
4	WCC60006	SPACER WHEEL BEARING FRONT
5	WCC60002	WHEEL SPACER 07 65 FRNT LEFT
6	BCC60003	BRAKE ROTOR FRONT
7	HCBC0612	6X12MM SHCS (4 REQ'D)
8	BAC60002	BRAKE ASSEMBLY FRONT AJP
9	HCBC0850	8X50MM SHCS
10	HCBC0820	8X20MM SHCS
	BCC60021	CALIPER ADJUSTMENT SHIMS 8MM ID
NOT SHOWN	BCC60013	BRAKE BRACKET
NOT SHOWN	HCBC0820	8X20MM SHCS
NOT SHOWN	HCBC0812	8X12MM SHCS LOW HEAD
	MCMUZT04	TIE WRAP (2 REQ'D)
ACCESSORY	BCC60006	REPLACEMENT HOSE -
ACCESSORY	BCC60024	BRAKE PADS
ACCESSORY	BCC60008	BRAKE LEVER – (OBSOLETE - MUST PURCHASE BAC60010)
ACCESSORY	BCC60009	MASTER CYLINDER - (OBSOLETE – REPLACED BY BAC60010)
ACCESSORY	BCC60010	PISTON REBUILD KIT
ACCESSORY	BCC60011	CALIPER

Parts –Bodywork



Plastic and Seat		
REF #	PART #	DESCRIPTION
NOT SHOWN	TCR62009	GRAPHIC KIT
1	TCC60001	FRONT FENDER
NOT SHOWN	HCBF0616	FENDER BOLT, M6X16 FLANGE HEAD (4 REQ'D)
NOT SHOWN	TCC60021	SPACER – FRONT FENDER BOLT
2	TCC60002	NUMBER PLATE – FRONT
NOT SHOWN	HCBF0612	M6X12 FLANGE HEAD BOLT – FRONT NUMBER PLATE MOUNT
3	TCC60003	RADIATOR SHROUDS – PAIR
NOT SHOWN	HCSP0003	PLASCREW – SHROUDS TO TANK (4 REQ'D)
NOT SHOWN	HCBC0501	M5X12 SOCKET HEAD – SHROUDS TO FRAME (2 REQ'D)
NOT SHOWN	HCBC0516	M5X16 SHOCKET HEAD-STROUDS TO RAD & EXH (2 REQ'D)
NOT SHOWN	HCCN0000	5MM EXTRUDED “U” NUT TO RAD & EXH (2 REQ'D)
NOT SHOWN	TCC60017	BODY PANEL WASHER 5MM (4 REQ'D)
4	TCC60009	FUEL TANK
5	TCHA0002	CAP – FUEL TANK
NOT SHOWN	TCHA0003	HOSE – FUEL CAP
NOT SHOWN	TCHA0005	SPACER – SEAT MOUNT
NOT SHOWN	HCFH0620	M6X20 FLAT HEAD – FRONT SEAT MOUNT
NOT SHOWN	TCHA0006	SPACER – FRONT TANK MOUNT
NOT SHOWN	HCBF0630	6MM X 30 FLANGE HEAD BOLT
NOT SHOWN	TCMU0151	FUEL PETCOCK
NOT SHOWN	RCC60012	FUEL LINE
NOT SHOWN	MCMUCL04	HOSE CLAMPS – FUEL LINE (2 REQ'D)
7	TAC60001	SEAT
NOT SHOWN	HCBC0625	M6X25 SOCKET HEAD CAP SCREW – SEAT HOLDING
NOT SHOWN	TCC60018	SPECIAL WASHER – SEAT HOLDING
8	TCC60005	SIDE NUMBER PLATE – PAIR
NOT SHOWN	HCBC0516	M5X16 SOCKET HEAD CAP SCREW (3 REQ'D)
NOT SHOWN	HCBF0630	M6X30 FLANGE HEAD BOLT – SILENCER (2 REQ'D)
NOT SHOWN	TCC60017	BODY PANEL WASHER 5MM (3 REQ'D)
NOT SHOWN	TCC60016	BODY PANEL WASHER 6MM (2 REQ'D)
9	TCC60007	FENDER – REAR
NOT SHOWN	HCSP0003	PLASCREW – FENDER TO AIRBOX (2 REQ'D)
NOT SHOWN	HCBC0516	M5x16 SOCKET HEAD CAP SCREW (2 REQ'D)
NOT SHOWN	HCWP0002	WASHER - BODY PANEL (2 REQ'D)
NOT SHOWN	HCHA0003	CLIP NUT – 6MM

Parts – Rear Brake

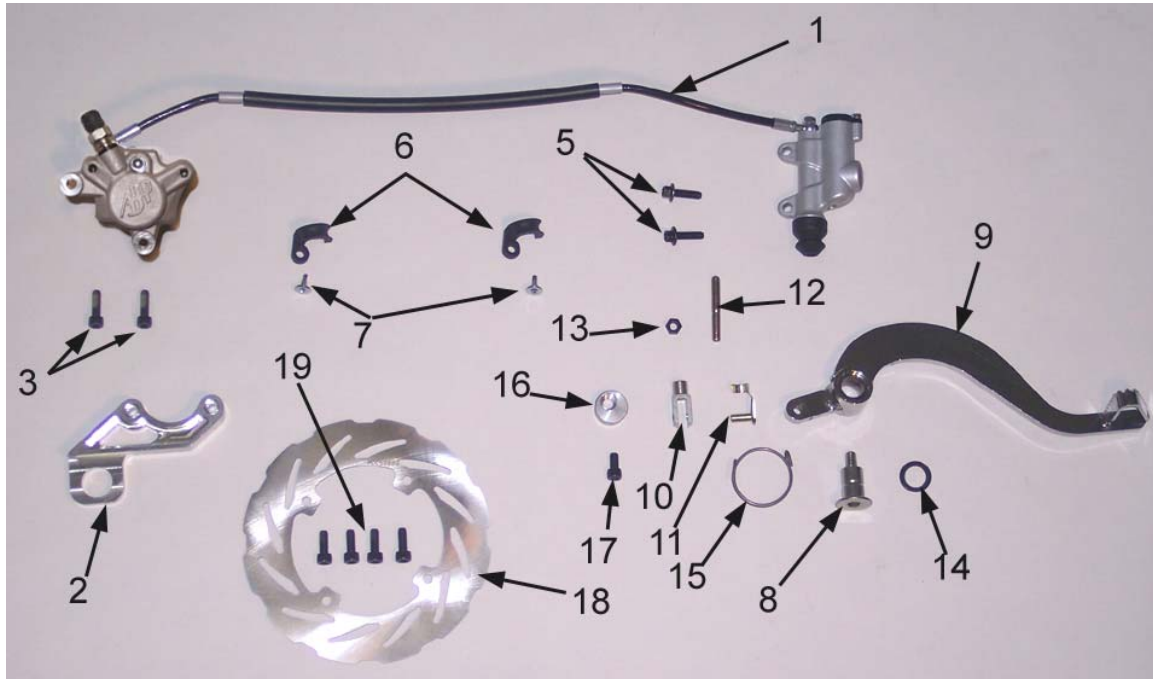

Rear Brake System		
REF #	PART #	DESCRIPTION
1	BAC60003	BRAKE ASSEMBLY REAR FORMULA
	BCEX0028	CALIPER – REAR BRAKE
	BCKG0012	MASTER CYLINDER - REAR
	BCMU0217	HOSE - REPLACEMENT
2	BCC60018	CALIPER BRACKET REAR
3	HCBC0601	6X16CS (2 REQ'D)
5	HCBF0620	6X20 FLANGE HEX-8MM HEAD
6	HCCC0005	BRAKE - HOSE GUIDE
7	HCPP0832	#8X1/2 SELF TAPING SCREW
8	BCDC0009	BRAKE PEDAL PIVOT BOLT
9	BCMU0012	BRAKE PEDAL-STEEL-05
10	BCMU0015A	BRAKE CLEVIS
11	BCMU0015B	BRAKE RETAINING SPRING PIN
12	BCC60020	PLUNGER THREADED FOR CLEVIS (65)
13	HCNS0601	6MM NUT FOR PLUNGER
14	BCMU0501	SEAL-BRAKE PEDAL
15	BCMUSP02	SPRING, REAR BRAKE PEDAL
16	FCEX0018	BRAKE ADJUST ECCENTRIC
17	HCBC0612	6X12 SHCS
18	BCC60004	BRAKE ROTOR REAR
19	HCBB0616	6X16 BUTTON WITH THREAD LOCK rotor bolts
ACCESSORY	BCEX0025	BRAKE PADS
ACCESSORY	BCKG0031	BLEED KIT (MULTIPLE SYRINGES, FITTINGS & HOSE)
ACCESSORY	BCKG0015	MASTER CYLINDER PISTON / SEAL KIT
ACCESSORY	BCKG0016	RESERVOIR SEAL KIT
ACCESSORY	BCEX0034	BANJO BOLT 8MM (CALIPER END)
ACCESSORY	BCEX0029	CRUSH WASHER 8MM (CALIPER END)
ACCESSORY	BCMU0220	BANJO BOLT 6MM (MASTER CYLINDER END)
ACCESSORY	ZCMUOR09	O'RING BANJO SEAL 6MM (MASTER CYLINDER END)

Parts – Rear Wheel

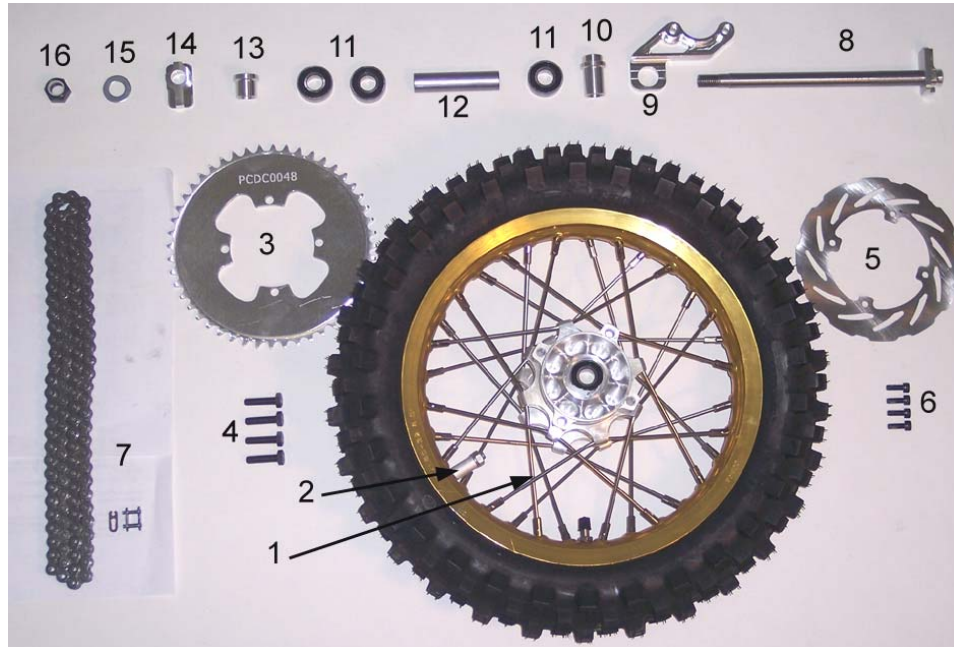

Rear Wheel		
REF #	PART #	DESCRIPTION
1	WAC6RR01B	WHEEL 12" REAR W BEARINGS (NO TIRE, TUBE, ROTOR OR SPROCKET) BLACK
	WCC6R012B	TIRE-BRDGESTNE-80/100-12M40
	WCC6R012D	TIRE – DUNLOP- 80/100-12 756
	WCDCHB02	HUB FOR CX65-REAR
	WCMU1200B	12" RIM, BLACK
	WCDCTU12	TUBE-275-80/100-12 REAR
	WCDC0010	RIM LINER 12" WHEEL
	WCDC0003	SPOKE-REAR WHEEL-65
	WCDC0011	NIPPLE-SPOKE 9GA. STAINLESS
	WCMU0109	WASHER-NIPPLE (NOT REQUIRED ON ALL MODELS)
2	WCDC0001	RIM LOCK FOR REAR WHEEL (32 REQ'D)
	WCDC0008	RIM LOCK SPACER-DC65
	HCNS0801	8MM NUT
	HCWF0801	8MM FLAT WASHER
3	PCDC00xxB	SPROCKET – xx denotes number of teeth, B indicates black anodyze
4	HCBH0825	8X25MM HEX HEAD (4 REQ'D)
5	BCC60004	BRAKE ROTOR REAR
6	HCBC1616	6X16 SHCS WITH THREAD LOCK (4 REQ'D)
7	PCR60001	CHAIN 420H 116 LINK CX65 GOLD
8	WCC60004	AXLE REAR 07 65
9	BCC60018	CALIPER BRACKET REAR AJP
10	WCC60003	WHEEL SPACER 07 65 REAR RIGHT
11	WCMU0120	BEARING, WHEEL
12	WCC60007	SPACER WHEEL BEARING REAR
13	WCC60005	WHEEL SPACER 07 65 REAR LEFT
14	GCC60010	CHAIN ADJUST BLOCK OFFSET
15	HCWF1400	14MM FLAT WASHER
16	HCNL1402	14MM LOCKNUT

Parts – Shock

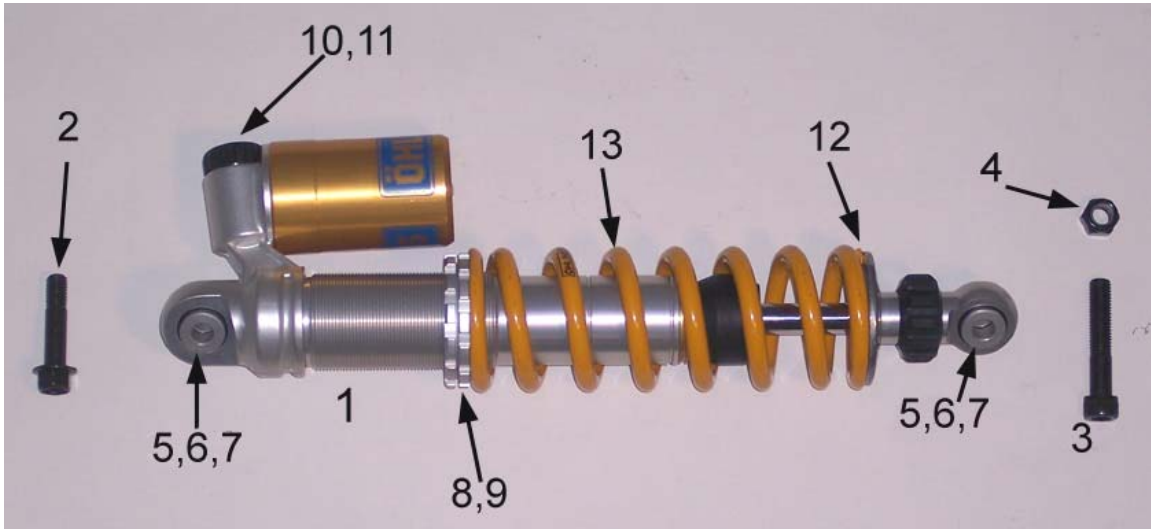

Shock		
REF #	PART #	DESCRIPTION
1	SAAX2007	SHOCK ABSORBER - CX65
2	HCBF1040	10X44 ENG FAST FLANGE HEAD
3	HCBH1055	10X55 HEX HEAD BOLT
4	HCNL1001	10MM LOCKNUT-REGULAR
5	SCKGOH03	BALL JOINT
6	SCKGOH11	O-RING FOR BALL JOINT
7	SCKGOH02	SPACER FOR BALL JOINT
8	SCKGOH04	SPRING PLATFORM (UPPER THREADED)
9	SCKGOH05	LOCKNUT
10	SCC60001	KNOB FOR ADJUSTMENT
11	SCKGOH21	SCREW FOR KNOB
12	SCKGOH01	SPRING PLATFORM (LOWER NONTHREADED)
13	SCC60240P	SPRING EXTRA LIGHT 240 LB/IN (42N/mm) (WHITE)
	SCC60260P	SPRING LIGHT 260 LB/IN (45 N/mm) (BLACK)
	SCEX1300	SPRING HEAVY 300 LB/IN (53 N/mm) (RED)

Parts – Swingarm Assembly

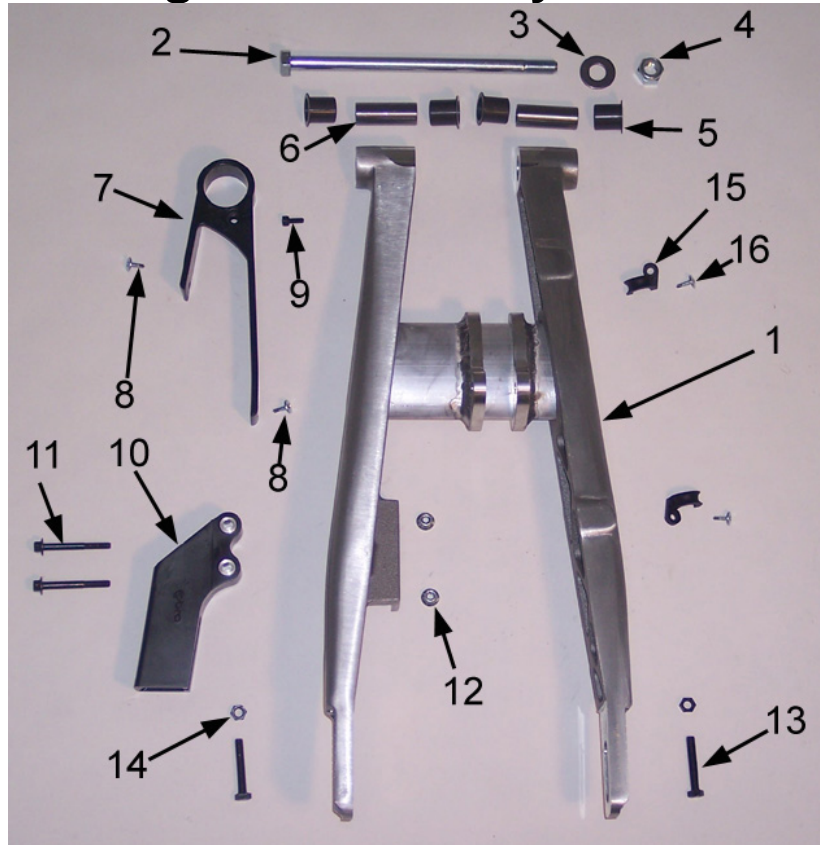

Swingarm		
REF #	PART #	DESCRIPTION
1	GACX6507	SWINGARM WELDED ASSY ALUMINUM
2	GCC60015	BOLT - SWINGARM PIVOT
3	HCWF1202	12MM WASHER – SWINGARM PIVOT
4	HCNL1201	12MM LOCK NUT – SWINGARM PIVOT
5	GCC60002	SWINGARM BUSHING 07 65 (4 REQ'D)
6	GCC60001	SWINGARM PIVOT TUBE SPACER 07 65 J(2 REQ'D)
7	TCC60004	CHAIN SLIDER TOP FOR SWINGARM
8	HCPP0832	#8X1/2 SELF TAPING SCREW (2 REQ'D FOR CHAIN SLIDER)
9	HCBC0501	5X12MM SHCS – CHAIN SLIDER MOUNT
10	PCC60004	CHAIN GUIDE (BOTTOM) CX65
11	HCBF0645	6X45 FLANGE HEAD BOLT (2 REQ'D)
12	HCNL0601	6MM LOCK NUT (2 REQ'D)
13	HCNS0701	7MM NUT (2 REQ'D)
14	HCBH0701	7X35 HEX HEAD FULL THREAD (2 REQ'D)
15	HCCC0005	BRAKE - HOSE GUIDE (2 REQ'D)
16	HCPP0834	#8X3/4 SELF TAPING SCREW (2 REQ'D)

Service

This portion of the manual is still under development. If you have questions please call the Cobra technical support line at 517 437 9100.

Engine Service

One method for determining whether the top end of your engine needs rebuilt is to perform a WOT (Wide Open Throttle) kicking compression test. Before performing the procedure please read the caution notes below.

CAUTION:

- There appears to be a wide range of variability in reading compression gauges across the country.
- The head volume of this Cobra Motorcycle is very small and so requires many kicks ~20 before you establish the most accurate reading possible.
- Because of the geometry of the spark plug used in this Cobra Motorcycle, the adapter used with your compression tester must have a similar volume protruding into the combustion chamber to establish an accurate value.
- Length of hose on the compression tester will affect the reading. The shorter the hose length the more accurate your reading will be.

Because of these difficulties in measuring an *absolute* compression value, a useful *relative* value can be achieved by testing your bike's compression with your own particular gauge after a new top end or when the bike is new so that you know what your particular gauge reads on a 'fresh' engine. When it has dropped to 90% of its original value the engine will be down on power and would benefit from a rebuild. When it's dropped to 80% it really needs rebuilt! Using the table below will help you determine monitor the condition of your top end.

	Engine is Fresh Measured Value	Engine Down on Power Measured Value * 0.9	Engine NEEDS Rebuilt Measured Value * 0.8
Example	110 psi	110 psi * 0.9 = 99 psi	110 psi * 0.8 = 88 psi
Your Values			

Procedure for Compression Testing

1. Shut off the fuel petcock.
2. Install the compression gauge into the spark plug hole.
3. Hold the throttle to wide open, and kick repeatedly (approximately 20 times) or until the gauge reading does not increase in value with each kick.

Base Gasket Selection

Tools required

- 17mm wrench
- 1mm flexible solder material
- measurement calipers

When rebuilding the 'top end' of your Cobra motorcycle, care must be taken to ensure the proper squish clearance. Squish clearance is defined as the minimum distance between cylinder head and piston at TDC, and there are negative effects of either having too much or too little clearance. Since parts like the crank, connecting rod, cylinder head, piston, and crankcases all have varying tolerances, Cobra offers several different base gasket thickness' to ensure that you can always set the squish clearance of your engine to factory specifications.

For base gasket replacement use the code (see figure 21 for location) along with the table on the following page reorder the correct thickness gasket.

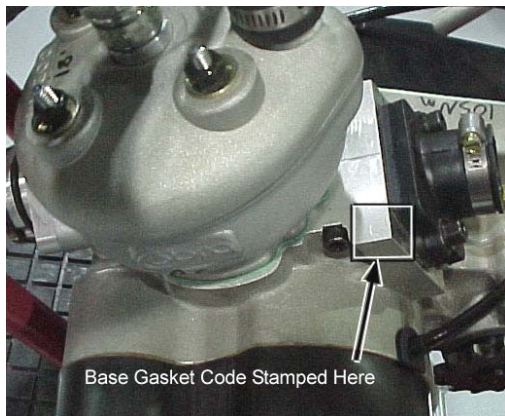

Figure 21

Code	Supplied Base Gasket Thickness		Cobra #
#	mm	inch	Without silicone bead
3-	0.25	0.010	ZCC60110
4	0.4	0.015	ZCC60115
5	0.5	0.020	ZCC60015
8	0.8	0.031	ZCC60130

NOTE

Tolerances will affect the actual gasket thicknesses.

If during the course of the maintenance more parts than the base gasket are changed, the squish clearance should be measured, and possibly a different base gasket will be required.

The easiest way to measure squish clearance is with 1mm to 1.5mm thick flexible solder wire (available through most popular electronic stores). The process is as follows:

- Assemble the top end of the engine with either; 1) the crankcase stamp recommended base gasket or, 2) if assembling with a new set of cases assemble with a 0.4mm (0.015") base gasket, and torque the head nuts to the proper torque specifications leaving off the spark plug and ignition cover (piston rings can be left off to ease assembly).
- Carefully insert the solder wire through the spark plug hole, into the cylinder far enough such that the tip of the wire touches the left or right side cylinder wall (not the front or back as the piston will rock more and give incorrect measurement).
- Hold the wire at this position and rotate the crankshaft, by the flywheel nut (or kick lever) three revolutions to 'smush' the solder wire.

CAUTION:

If you rotate the flywheel nut in a counterclockwise direction there is a risk of loosening the nut.

- Pull out the wire and measure the solder thickness at the thinnest location near its tip accurately with the thin tips of calipers.
- Adjust base gasket thickness as necessary to get the desired value.

Upon completion, your final assembly squish clearance should agree with the chart below

Measured Squish Clearance (minimum)

(These numbers only apply when measured as described above)

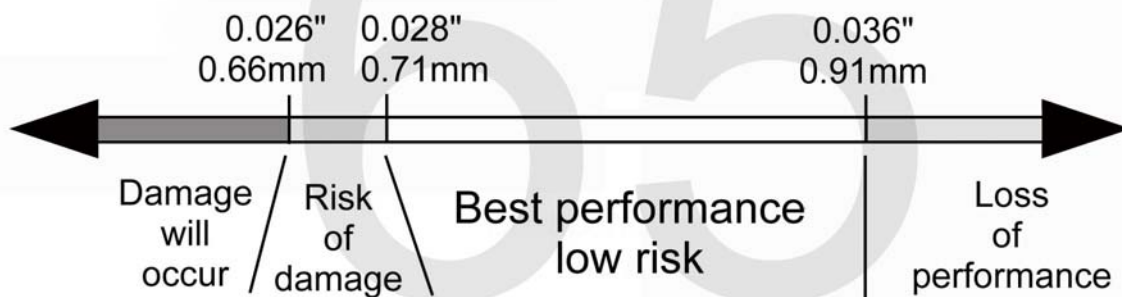

Fuel & Air System

Carburetor:

Tools recommended for carburetor service:

- Small flat head screwdriver
- WD-40
- 6mm socket

Your Cobra is equipped with an adjustable carburetor. Some fine-tuning may be needed according to weather condition and altitude. Proper jetting is **very** important for engine performance and engine life. Serious damage to the engine can occur if not properly adjusted.

IDLE ADJUSTMENT:

On the each side of the carburetor, there are two adjustment screws. The right side screw with the knurled head is the idle adjustment screw. To raise the idle, turn the screw in clockwise (in 1/4 turn increments) and rev the engine after each adjustment. To lower the idle, turn the screw counter-clockwise.

TOP END JETTING:

Indications that the engine is running too rich (too much fuel for the air) are:

- Engine not revving out or blubbering at high RPMs.
- Engine will not 'clean out'
- Wet or black spark plug

NOTE: Before changing jetting be sure that the air filter is properly cleaned and has the usual amount of air filter oil. An overly dirty air filter can cause the engine to run rich.

If the engine is running rich on the top end it should be leaned out. Leaning it out can be done by:

1. Changing the main jet to a smaller number.
2. Raising the needle clip (this lowers the jet needle) one notch at a time on the slide.

Indications that the engine is running too lean are:

- Engine cutting out on top end.

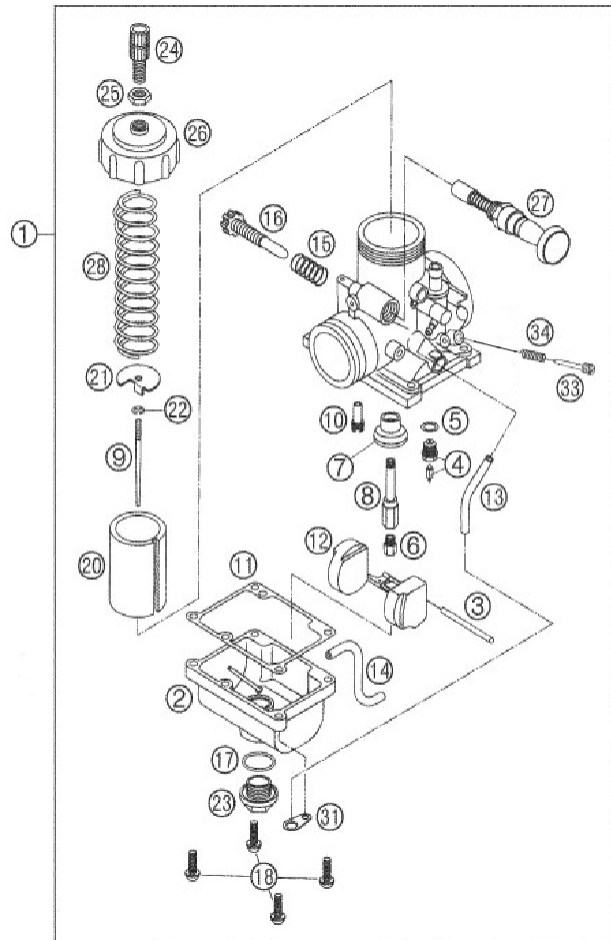

- Engine overheating and ultimately seizure.
- White spark plug

CAUTION:

It is much safer to operate the engine slightly rich as opposed to slightly lean. This is because an overly rich engine will just run poorly while an overly lean engine will seize, potentially causing an expensive top end rebuild and a DNF.

To richen the carburetor:

1. Change the main jet one number at a time (larger).
2. Lower the needle clip (raising the jet needle) one notch at a time until the engine starts to blubber on the top end, then move the clip back up one notch or until you get the blubber out.

FUEL MIXTURE SCREW

The left side brass screw is a fuel mixture (air) screw. This screw will also richen and lean your engine more on the bottom and mid-range. In warmer conditions, turn the screw in. In colder conditions, turn the screw out. Be sure to keep the carburetor very clean and make sure you don't have water or dirt in the carburetor bowl. Use automotive carburetor cleaner or WD-40 to clean the carburetor inside and out. Turning the screw in richens the mixture at partial throttle openings. Turning the screw out, leans it.

STOCK CARBURETOR SETTINGS

The 2009 CX65 stock carburetor settings from the factory are:

- 40 pilot jet
- 210 main jet

Cleaning the carburetor:

 WARNING

Clean the carburetor in a well-ventilated area, and take care that there is no spark or flame anywhere near the working area; this includes any appliance with a pilot light. Because of the danger of highly flammable liquids, do not use gasoline or low flash-point solvent to clean the carburetor.

1. Make sure the fuel is shut off.
2. Remove the carburetor.
3. Drain the fuel from the carburetor.
4. Disassemble the carburetor.
5. Immerse all the metal parts in a carburetor cleaning solution.
6. After the parts are cleaned, dry them with compressed air.
7. Blow out the fuel passages with compressed air.
8. Assemble the carburetor
9. Install the carburetor onto the motorcycle.

Rear Shock

The rear shock is fully serviceable but it is recommended that only trained professionals should service your shock. Contact Cobra or another qualified specialist (PR2, MCR, etc..) for questions and service of your CX65shock.

Shock preload

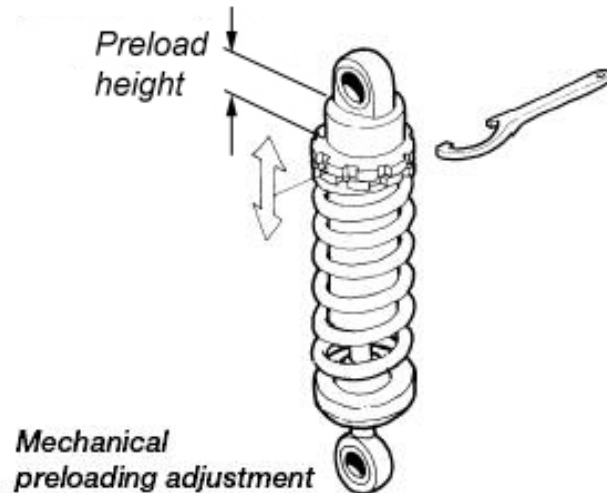

Shock Damping

11. Adjustment of rebound damping

12. Adjustment of compression damping

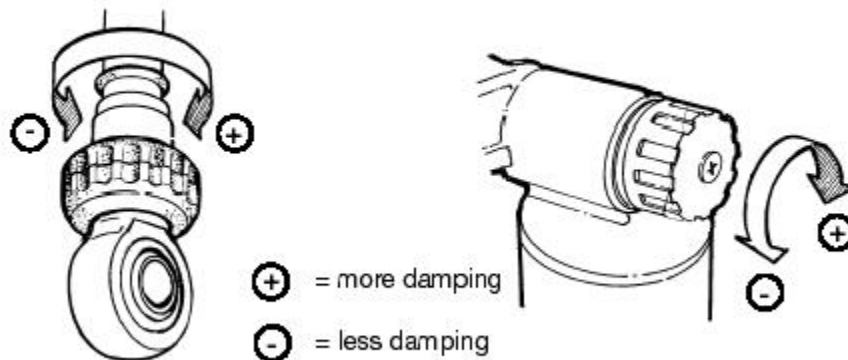

Tuning

Gearing

Front Sprocket			Rear Sprocket	Gear Ratio
		15	37	2.47
		15	38	2.53
		15	39	2.60
	14		37	2.64
		15	40	2.67
	14		38	2.71
		15	41	2.73
	14		39	2.79
		15	42	2.80
13			37	2.85
	14		40	2.86
		15	43	2.87
13			38	2.92
	14		41	2.93
		15	44	2.93
13			39	3.00
	14		42	3.00
		15	45	3.00
		15	46	3.07
	14		43	3.07
13			40	3.08
12			37	3.08
		15	47	3.13
	14		44	3.14
13			41	3.15
12			38	3.17
		15	48	3.20
	14		45	3.21
13			42	3.23
12			39	3.25
		15	49	3.27
	14		46	3.29
13			43	3.31
12			40	3.33
		15	50	3.33
	14		47	3.36
13			44	3.38
		15	51	3.40

Suspension

Adjustment:

1. Front forks
 - 1.1. Fork oil
 - 1.1.1. Oil type
 - 1.1.1.1. Heavier weight oil – more damping – slower responding
 - 1.1.1.2. Lighter weight oil – less damping – quicker responding
 - 1.1.2. Oil quantity / level
 - 1.1.2.1. Greater quantity / higher level – greater bottoming resistance, stiffer near the end of the travel.
 - 1.1.2.2. Smaller quantity / lower level – less bottoming resistance, less stiff near the end of the travel.
 - 1.2. Fork spring
 - 1.2.1. Stiffer spring (higher spring rate) – stiffer throughout the travel.
 - 1.2.2. Less stiff spring (lower spring rate) – less stiff throughout the travel.
 - 1.3. Gas pressure – always bleed off any pressure.
 - 1.4. Fork height
 - 1.4.1. Rise in clamps for quicker turning.
 - 1.4.2. Lower in clamps for improved straight line stability.
2. Rear shock
 - 2.1. Preload adjustment
 - 2.1.1. More preload (greater distance) – less race sag.
 - 2.1.2. Less preload (smaller distance) – more race sag.
 - 2.2. Shock spring
 - 2.2.1. Stiffer spring – stiffer throughout the travel.
 - 2.2.2. Less stiff spring – less stiff throughout the travel.
 - 2.3. Compression damping
 - 2.3.1. Harder (more damping, slower) – adds resistance to the suspension motion when the suspension is compressing.
 - 2.3.2. Softer (less damping, quicker) – reduces resistance to the suspension motion when the suspension is compressing.
 - 2.4. Rebound damping
 - 2.4.1. Harder (more damping, slower) – adds resistance to the suspension motion when the suspension is returning to full length.
 - 2.4.2. Softer (less damping, quicker) - reduces resistance to the suspension motion when the suspension is returning to full length

Front Forks Bottoming Too Frequently

Fork oil level

If the front forks bottom harshly more than a couple of times per lap and the fork springs are proper for the weight of rider (as detailed above), try raising the fork oil level in increments of 10mm. Raising the fork oil level, reduces the air volume, and increases the stiffness of the forks late in the travel, thus adding a progressive' feel.

Front forks feel too stiff over small bumps.

Fork oil weight

If the forks feel too stiff over small bumps try decreasing the weight (increasing the viscosity) of the fork oil.

Rear suspension troubleshooting.

Damping

Always start with standard settings and make damping changes in no more than two click increments and only make one change at a time.

Symptom	Action
Rear end feels stiff on small bumps	Softer compression damping
Rear end 'sways' on straights	Harder compression damping
Bike tends to jump 'rear end high'	Harder rebound damping
Bike tends to jump 'rear end low'	Softer rebound damping
Frequent rear end bottoming	Harder compression damping
Bottoms after end of continuous bumps	Softer rebound damping
Rear end 'kicks' over square edge bumps	1) Harder rebound, 2) Softer Compression

Proactive Suspension Adjustments

Once you have the suspension adjusted for decent overall feel, you can make proactive adjustments when faced with different racing conditions.

Situation	Actions
Sand track	Lower the rear end (increase race sag).
Sand track	Stiffer compression and rebound damping.
Long fast track	Lower the forks in the clamps by 3 mm.
Tight slow track	Raise the forks in the clamps by 3 mm.
Mud track	Lower the bike if the rider has difficulties touching the ground.

Carburetion

Although your Cobra is sent from the factory with the carburetor jetted for optimal performance, you may find it necessary to adjustment your particular jetting due to current weather conditions, altitude, fuel variations, and/or engine modifications.

CAUTION:

Proper jetting is very important for engine performance and engine life. Symptoms of improper jetting are listed below.

- Symptoms of incorrect oil or oil / fuel ratio
 - Poor acceleration
 - Misfire at low engine speeds
 - Excessive smoke
 - Spark plug fouling
 - Excessive black oil dripping from exhaust system
- Symptoms of too rich a fuel mixture
 - Poor acceleration
 - Engine will not 'rev' out, blubbers on top
 - Misfire at low engine speeds
 - Excessive smoke
 - Spark plug fouling
 - Wet, black, or overly dark spark plug (when removed for inspection)
- Symptoms of too lean a fuel mixture
 - Pinging or rattling
 - Erratic acceleration
 - Same actions as running out of fuel
 - High engine temperature
 - White spark plug (when removed for inspection)

NOTE:

When inspecting the spark plug to evaluate jetting, a properly jetted machine will produce a spark plug that is dry and light tan in color.

Environmental and altitude related mixture adjustments		
Condition	Mixture will be	Required adjustment
Cold air	Leaner	Richer
Warm air	Richer	Leaner
Dry air	Leaner	Richer
Very humid air	Richer	Leaner
Low altitude	Standard	None
High altitude	Richer	Leaner
Low barometric pressure	Richer	Leaner
High barometric pressure	Leaner	Richer

NOTE:

- Before making any carburetor jetting changes verify that:
 - You are using the proper fuel and oil
 - The fuel is fresh and uncontaminated
 - The oil and fuel have been mixed in the proper ratio
 - The carburetor is clean (no plugged jets)
 - The air filter is properly clean and oiled
 - The float height is within proper specification (proper measuring technique is described later in this section)

NOTE:

Perform all jetting changes on a motorcycle that has been warmed up to proper operating temperature.

The carburetor on your Cobra motorcycle is quite adjustable. Figure 49 shows its range of adjustment and in particular what adjustable component affects what range of operation (specifically throttle position).

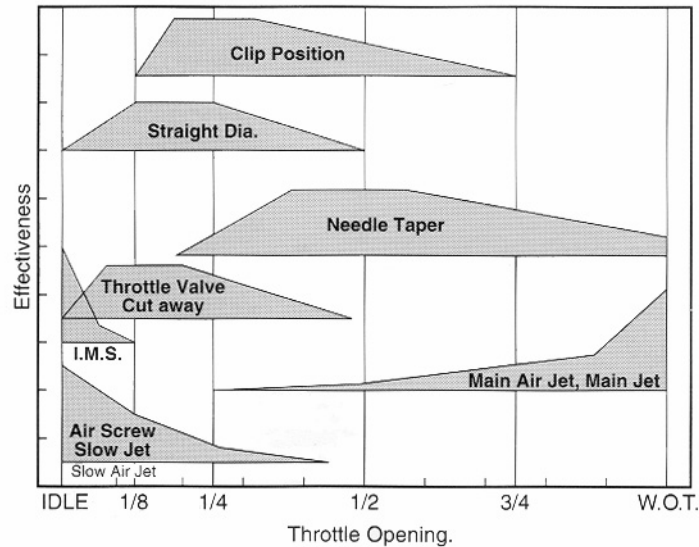

FUEL SCREW ADJUSTMENT: **Adjust for throttle response**

The air adjustment screw is located on the left side of the carburetor. It requires the use of a small flat blade screw driver for adjustment. After adjusting for proper throttle response, use the idle screw to adjust the desired idle speed.

NOTE:

If the air screw requires more than 3 turns out, replace the pilot jet for one that is one size leaner (smaller number) then readjust the fuel screw.

IDLE ADJUSTMENT: **Adjust for desired idle speed**

The idle speed screw is located on the right side of the carburetor. It is hidden behind the exhaust stinger pipe and is barely reachable with a screwdriver. To raise the idle, turn the screw in, clockwise, (in 1/4 turn increments) and rev the engine after each adjustment. To lower the idle, turn the screw counter-clockwise.

TOP END JETTING: **Adjust for clean full throttle acceleration**

Jet your top end (main jet) based on the acceleration of your Cobra Motorcycle on the longest straight at the track. Observe any of the lean or rich symptoms (spark plug appearance and bike performance) listed above and change your jetting accordingly.

PART THROTTLE **Adjust for desired acceleration**

Using an area of the track that allows the rider to operate and mid throttle and transition (accelerate, or 'roll on') from closed, or mostly closed throttle, to a larger throttle opening. Observe the rich and lean symptoms listed above. Adjust the jet needle position by moving the clip from its current position (move the clip higher on the needle to make the bike run leaner, or move the clip lower on the needle to make the bike run richer) to one higher or lower.

Troubleshooting

1) Engine operates erratically

- a) Carburetor top is installed backwards
- b) The carburetor slide indexing pin is missing
- c) A carburetor vent elbow is plugged or has fallen out
- d) Faulty stator
- e) An air leak
 - i) Base gasket
 - ii) Intake / reed gaskets
 - iii) Crank seals
 - iv) Crank case gasket

2) Engine is down on power

- a) Jetting is incorrect
- b) Silencer needs repacked
- c) Exhaust pipe
 - i) Has excess carbon buildup
 - ii) Has large dent in it
- d) Compression is low
 - i) Piston
 - ii) Rings
- e) Reeds are damaged
- f) Ignition timing is incorrect
- g) Stator needs replaced

3) Engine is excessively loud

- a) Silencer needs repacking

4) Engine 'blubbers' at high RPMs

- a) Jetting too rich
- b) Stator needs replaced

5) Engine won't start

- a) Fuel
 - i) None in tank
 - ii) Is sour or bad

- b) Carburetor is dirty
 - c) Ignition
 - i) Spark plug fouled
 - ii) Spark plug cap off
 - iii) Engine Shut-off 'kill' switch is shorted
 - iv) Bad electrical ground
 - v) Stator winding damaged
 - d) Exhaust is plugged with object or flooded fuel
 - e) Engine is flooded
 - f) Cracked, broken, or jammed reed pedal
 - g) Excessive piston or cylinder wear
 - h) Clutch bolt or shoe dragging on basket (drum).
- 6) Engine won't idle**
- a) Idle knob needs adjusted
 - b) Carburetor jets are dirty
 - c) Choke is stuck on
 - d) Air leak

Index

Air Filter Maintenance	12	Frame Parts	30
Bars and Controls	16	Front Brake	
Base Gasket Selection.....	38	Parts	31
Break-In	6	Fuel System	
		Parts list.....	40
		Service.....	40
Carburetor		Hardware	
Parts	17	Frame	30
Service	40	Plastic.....	32
Specifications	3	Jetting	
Chassis		How To	40
Specification	3	Stock.....	3
Clutch.....	21	Troubleshooting.....	45
Clutch Cover	22	Kick Mechanism	24
Clutch Lubricant		Lubrication	
Replacing	10	Recommended	3
Compression test	38	Maintenance	
Cylinder.....	26	Schedule.....	8
Cylinder head		Tips.....	8
torque	5	Oil	
Electrical		Recommended	3
Parts.....	20	Optional components	4
Engine		Parts	
Specifications	3	Bars and Controls	16
Exhaust			
Parts.....	28		
Fork Oil			
Replacement	13		

Carburetor	17	Parts	35
Coolant System	15, 19	Service.....	47
Electrical.....	20	Spark Plug	
Exhaust	28	Recommended	3
Frame	30	Specifications	3
Front Brake	31	Starting.....	7
Plastic & Seat	32	Stator	
Rear Brake	33	torque	5
Rear Wheel	34	Suspension	47
Shock	35	Swingarm Parts.....	36
Swingarm	36		
Piston.....	26	Top End	
Plastic & Seat Parts	32	Parts	26
		Service.....	37
Rear Brake		Torque Values.....	5
Parts.....	33	Transmission.....	27
Rear Wheel		Transmission Lubricant	
Parts.....	34	Replacing.....	10
<u>Reeds</u>	42	Troubleshooting	48
Rings.....	26	Jetting.....	45
shift drum	27	VIN reading	8
shift forks	27		
Shift Mechanism	25	WARNING.....	0
Shock		Water Pump Cover.....	22