

**FX3E**



**CHAMPIONS START HERE.™**

*Owners  
Parts  
Service  
Tuning*

For **parts orders**, contact your local dealer.

To locate your closest Cobra dealer, log on to

[www.cobramoto.com](http://www.cobramoto.com)

or call

+1 (517) 437 - 9100



Cobra MOTO, LLC  
240 Uran Road  
Hillsdale, MI 49242  
USA

## DISCLAIMER OF WARRANTY

*This motorcycle is sold "as is" with all faults, obvious or not. There are no warranties expressed or implied, including any warranty of merchantability and warranty of fitness for any particular purpose.*

*Motorcycles are generally not covered by homeowner or trailer content insurance, and they typically require their own policy. Contact your own insurance company for specific details.*

### **"WARNING"**

THE COBRA CX5E IS A COMPETITION MODEL ONLY AND IS NOT MANUFACTURED FOR, NOR SHOULD IT BE USED ON PUBLIC STREETS, ROADS, OR HIGHWAYS.

THE USE OF THIS BIKE SHOULD BE LIMITED TO PARTICIPATION IN SANCTIONED COMPETITION EVENTS UPON A CLOSED COURSE BY A SUFFICIENTLY SKILLED RIDER AND SHOULD NOT BE USED FOR GENERAL OFF-ROAD RECREATIONAL RIDING.

IMPROPER USE OF THIS MOTORCYCLE CAN CAUSE INJURY OR DEATH.

THIS BIKE IS INTENDED FOR EXPERIENCED RACERS ONLY AND NOT FOR BEGINNERS.

IT IS YOUR RESPONSIBILITY AS THE OWNER OF THIS COBRA MOTORCYCLE OR AS THE PARENT, OR LEGAL GUARDIAN OF THE OPERATOR, TO KEEP THIS COBRA MOTORCYCLE IN PROPER OPERATING CONDITION.

THIS BIKE WAS DESIGNED FOR RIDERS THAT WEIGH LESS THAN 80 LBS WITH FULL RIDING GEAR AND SHOULD NOT BE OPERATED BY RIDERS THAT WEIGH MORE THAN THAT.

BE SURE THAT THE RIDER ALWAYS WEARS ADEQUATE SAFETY GEAR EVERYTIME HE OR SHE RIDES THEIR COBRA MOTORCYCLE.

### **"WARNING"**

***This product contains Lithium-Ion battery cells which are very good at storing a lot of energy for a fast fun motorcycle but are potentially very dangerous. For your family's safety, follow the instructions on the next page***

## IMPORTANT SAFETY NOTICE

### **⚠ WARNING**

Failure to follow WARNING instructions could result in severe injury or death to the machine operator, a bystander, or a person inspecting or repairing the machine.

### **CAUTION:**

A CAUTION indicates special precautions that must be taken to avoid damage to the machine.

**NOTE:** A NOTE provides key information to make procedures easier or clearer.

# **Lithium-Ion Battery Safety**

**When not preparing for a race, store the battery with partial charge (2 lights lit, not 3, only the red “S” light and orange “V” lights lit), and away from heat sources.**

**Store and charge your Cobra CX-E in a place where a fire would cause the least harm.**

Additional best practice guidelines below:

- Tampering with the battery, charger, and/or electronics of the motorcycle would be jeopardizing safety.
- Do NOT use Electrolytic Grease or other contaminants on the battery power connector terminals.
- Fully charge the battery **only just prior** to using it.
- Battery / bike Storage (2 lights of charge as stated above)
  - Not in direct sunlight, temperature between 32°F – 110°F (cooler better)
  - Keep away from other heat sources that allow the surface to be ‘hot’ to the touch (115°F)
- Transportation of batteries to protect against shock or impact (2 lights of charge):
  - Batteries are best transported in the motorcycle, covered with a Lithium – Ion fire suppression blanket and protected from contact with other items.  
<https://brimstonefireprotection.com/>
  - Batteries not in the motorcycle should be kept in a container (2 lights of charge):
    - Lithium-Ion safe battery case for 1 kWh capacity (in case of energy release). <https://www.denios-us.com/lithium-ion-transport-box-M2921000/M292100>
    - Or minimally an impact absorbing case to avoid sliding, dropping, or impacts during transport. (This will not contain spontaneous energy release but will protect it from unintended impacts. [Available soon from Cobra.](#))
- Clean the battery pack by hand – NOT WITH PRESSURE WASHER.
- When cleaning the battery outside of the bike (recommended) install connector sealing covers to avoid contamination of the terminals.
- A battery that has been dropped or has crash damage should be isolated to a safe location (assume it could ignite at any time). Keep isolated and call Cobra tech ASAP 517 437 9100.
  - Signs of internal heat, escaping smoke, or hissing noise – get away fast, otherwise,
  - Does the housing appear compromised (dent, crack, etc..)?
  - Will the battery pack power up?
  - What is the state of charge?

# Table of Contents

<b>LITHIUM-ION BATTERY SAFETY</b> .....	2
<b>GENERAL INFORMATION</b> .....	5
SPECIFICATIONS - GENERAL.....	5
OPTIONAL SUSPENSION COMPONENTS.....	6
SPECIFICATIONS - TORQUE VALUES.....	7
POWER UP PROCEDURE .....	8
<b>MAINTENANCE</b> .....	11
TIPS .....	11
SCHEDULE .....	12
REPLACING MOTOR COOLING FLUID.....	13
PROPER CHAIN ADJUSTMENT .....	13
REAR BRAKE PEDAL HEIGHT.....	15
FORK MAINTENANCE.....	16
<i>Fork Air Bleeding</i> .....	16
<i>Fork Oil Replacement</i> .....	16
DISASSEMBLY PROCEDURE .....	17
PARTS – BATTERY .....	19
PARTS .....	20
– ELECTRICAL SYSTEM .....	20
PARTS – ELECTRONICS BOX.....	21
PARTS – FORKS & TRIPLE CLAMPS.....	22
PARTS – FORKS – LEG ASSEMBLY – BRAKE SIDE .....	24
PARTS - FORKS – LEG ASSEMBLY – NON-BRAKE SIDE.....	25
PARTS – FRAME & SUBFRAME.....	26
PARTS – FRONT BRAKES.....	27
PARTS – FRONT WHEEL .....	28
PARTS – MOTOR SYSTEM - INTERNALS.....	29
PARTS – PLASTIC BODYWORK & SEAT - E3.....	32
PARTS – REAR BRAKE .....	34

PARTS – REAR WHEEL .....	36
PARTS – SHOCK .....	37
PARTS – SHOCK - INSIDE .....	38
PARTS – SWINGARM ASSEMBLY .....	39
<b>SERVICE .....</b>	<b>40</b>
ON BOARD DIAGNOSTICS .....	40
MOTOR COOLING FLUID REPLACEMENT .....	42
REAR WHEEL PULLERS .....	42
BRAKES .....	43
FRONT FORKS .....	43
REAR SHOCK .....	43
<b>TUNING .....</b>	<b>44</b>
GEARING .....	44
<i>Front Fork Operation</i> .....	45
<i>Fork Damping Adjustments</i> .....	<i>Error! Bookmark not defined.</i>
<i>Rear Shock Adjustments</i> .....	45
<b>TROUBLESHOOTING .....</b>	<b>47</b>

# General Information

## Specifications - General

Items	CX50 FWE
<b>Dimensions</b> Wheelbase Wheel size Seat height	36.00" (914mm) 10" (254mm) rear 23.9" (607 mm)
<b>Motor</b> Type Cooling system Coolant Final drive ratio Chain	Cobra – out runner Liquid-cooled Cobra Motor Cooling Fluid, 500 ml 10/50 T 110 links 420
<b>Chassis</b> Front tire Pressure Rear tire Pressure Front fork Fork oil type Fork oil amount Std settings (turns) Rear shock (std. settings)	2.75 (80/100) - 10" 15 psi min 2.75 (80/100) - 10" 16 psi min. (20 psi for hard pack or rocky conditions) CARD 32mm USD Fully Adjustable w/ Smart Leg 5wt Fork Oil 140 ml Smart leg: 3 out, Compression and rebound 1-1/2 Compression Low 7clicks, High 7clicks, Rebound-N/A Race sag 50mm, Free sag 16mm

# Optional Suspension Components

Weight of Rider (lb)	Fork Spring	Shock Spring
Less than 38 (light)	KCCJ3218 (10 lb/in, .18 kg/mm)	SCMUOH04 (275 lb/in) red
38 – 45 (std)	KCCJ3221 (12 lb/in, .21 kg/mm)	SCMUOH05 (285 lb/in) yellow
46 to 55 (stiff)	KCCJ3225 (14 lb/in, .25 kg/mm)	SCMUOH06 (295 lb/in) white



# Specifications - Torque Values

Fastener	Torque Value			Loctite™	Size & Remarks
	ft-lb	in-lb	Nm		
Phase & power to MDU	4.4	53	6.0	No	M5 x 0.8
Phase wires to Motor	3.0	35	4.0	no	M6x1.0, copper
Motor mount bolts	22	265	30		M8 X 1.25
Swingarm pivot	21	250	28		M14 X 2.0
Shock bolt	35	420	47	243	M10 x 1.5
Rear axle nuts	21	250	28		M12 X 1.25
Rear sprocket bolts	21	250	28		M7 X 1.0
Front axle aluminum bolt	18	221	25	Moly lube	M10 X 1.25
Fork guard alum bolts	6	88	8	243	M6X1, ALUM
Front axle pinch bolts	7.5	88	10		M6 x 1.0
Brake caliper bolts	9	106	12	243	M6 x 1.0
Brake caliper to carrier	7	84	9.5	243	M6 x 1.0
Brake pad secure	3	36	4		M5 x 0.8
Banjo bolts – brakes	15	177	20		M8 x 1.25
Brake rotor bolts	9	108	12	243	M5 x 0.8
Triple clamp bolt (top)	8	90	10		M8 x 1.25
Steering stem pinch bolt	9.5	115	13		M8 x 1.25
Triple clamp bolts (bottom)	6	72	8		M6 x 1.0

# Power Up Procedure

- Before Powering Up the machine inspect the following
  - Tire pressure
  - Chain tension
  - Cooling fluid level
  - Proper wear on chain rollers and sliders
  - Handlebar tightness
  - Throttle assembly movement
  - Check for loose nuts and bolts
- Turn the battery on by pressing the **Power Button** for 1-2 seconds

## **WARNING**

Always wear a helmet and other protective riding gear.

**CAUTION:** Make sure your rider's foot is not resting on the foot brake while they are riding.

### **For charging...**

Ensure good AC power....if not, fast charging may produce faults.... however, slow charge is still an option on slightly bad power.

### **Charging Procedure:**

Plug Charger into AC, then Plug into battery with Positive wire towards the back of the bike...while turning the lock ring clockwise to lock it down. Ensure that the connector goes together evenly. Then press the battery power button once and wait a few seconds. The voltage indicator on the battery will start flashing slowly (slow charge). Then hit the battery power button one more time and the voltage indicator will now start flashing faster.

Slow Charge: 3.5-4 hours, Fast Charge: 1-1.25 hour. Once all the lights on the battery charge indicator are solid and not flashing charging is complete. Low power chargers will only slow charge. High power chargers have both charge modes.

There is a new "**Pre-Race**" charge mode... once battery is already full. Turn battery off with long press on the battery power button....then back on. When the battery sees that it is already charged it will run the "Pre-Race" algorithm... and prepares the pack for maximum runtime.

# Do's and Don't's

## Don't:

1. Don't store the battery fully charged.

### **WARNING**

Energy stored in Lithium-Ion battery packs have the potential to accidentally / unintentionally release their energy rapidly if an internal cell becomes compromised. Less energy to release is better.

2. Don't leave battery with 1 light on charge indicator for extended time.

### **CAUTION:**

A battery stored with only 1 light of charge may run out of energy while resting on the shelf and it's not possible to recharge a battery after it discharges beyond a certain point.

3. Don't wash improperly. See washing best methods.
4. Don't fill with anti-freeze.

### **CAUTION:**

Motor Coolant is not engine Anti-Freeze!...it is petroleum based with special additives. Anti-Freeze is conductive and will damage the bike.

5. Don't totally fill the cooling system. There is coolant in the system even though you can't see it when taking the cap off. With the bike on the stand and powered up, apply some throttle and you should see fluid flowing in the radiator... that is all you need to see!
6. Don't put grease on the power contacts of the battery power connector. Grease is not a good electrical conductor. It works fine on 12V low current trailer light connection to keep water out and avoid corrosion, but acts like a current drawing resistor when applied to the bikes battery.
7. Don't over tighten rear axle as this could add drag to the motor.
8. Don't plug or unplug the battery from the bike or charger with it turned on!

## Do:

1. Do charge the battery to 2 lights on battery indicator before storing. Bike can be plugged into battery when stored.
2. Do check chain sliders and sprockets for wear regularly.
3. Do change cooling fluid every 3 months.
4. Do lube chain between each moto.
5. Do turn off the battery before plugging in or unplugging from the charger or bike!

## For those serious racers:

1. Warm up motor before racing for better starts. Feel radiator with hand until close to normal running temp is reached.
2. Top off battery after warm up cycle. This is a balance as motor temp is cooling while charging.

3. Adding a couple psi to rear tire would improve top speed and runtime, but at the cost of a little initial traction.
4. If run time is a priority, please see "Pre-Race" charge mode.

### **Change Bike Modes:**

Bike must be disabled ("Active" light is off), before mode can be changed. Hitting the "GO" button activates and deactivates the bike.

Add the LED light numbers to get the mode number. So if 1 and 3 are lit, then that is mode 4. Hitting the upper Left Mode button cycles through modes.

### **Modes:**

1. Mode 1 is the lowest power setting and should get over 45mins of ride time.
2. Modes 2-6 are of increasing power and speed.
3. Mode 6 is the highest power setting and should provide around 20mins of ride time.
4. These modes require the Yellow kill switch key.

**It is NOT AMA legal to race the E3 with the Red kill switch key**

### **Holeshot Mode:**

1. The 3E does not have a holeshot mode....although mode 6 is fairly quick.

### **Washing:**

1. Please pull the battery out of the bike to wash(it's just three 11mm nuts).... that would eliminate 75-95% or more of the electrical problems ebikes tend to have either way.
2. Check for dirt/mud in main bike connector and clear with Q-tip or paper towel. There is also a Bike side block off plug Item# DCCEMU002 to keep the bike side connector free of water and dirt.
3. Wash RDU and Tank area sparingly, avoid direct pressure spray.
4. Allow ample drying time, do not store in enclosed area while wet.
5. Be mindful of anything with wires coming out of it. Things can be waterproof, but those same things may not be pressure washing proof.

### **Other:**

1. While on track, if active light starts flashing....either from falling over and being tilting too long or kill switch key falling off... when issue is resolved, one button press of the "GO" button will reset and allow rider to continue on.
2. If lower red fault light(Lightning bolt) comes on while riding and bike will not run... This fault light is a "catch all" for other bike system issues...kill switch, motor sensors, non-zero throttle, loss of CAN bus etc. Check the "ON BOARD DIAGNOSTICS" for further information.
3. Lower left fault light(Battery) indicates an issue with the battery and needs to be looked at. Check battery indicators for fault code. IE. "M" light is red and another Letter is lit red as well. Disconnect battery from bike and turn battery on to confirm battery fault.
4. After sitting a few weeks or from brand new... batteries will need a few runs to "Wake" up. Performance will improve over that time. Approx 4 or 5 cycles.

5. Sprocket options are available We have 48, 49, 50 and 51t Check with your dealer.

**Other issues:**

1. While we feel we have taken care of the all of the issues we are aware of, there is still the possibility of other small bugs or a parts failure(Electronics, batteries or wiring) that could be possible. We will do our best to find any new issues and fix ASAP.
2. Doing troubleshooting remotely is no fun for anyone. We have options to get a diagnostic tool in people's hands as quickly as possible. A dealer diagnostic tool is also available which several dealers already have.
3. Battery change can happen in under 1 min. No serial number or programing change needed. Potential for 1 practice pack to ride bike to the line(warmup), then swap battery in staging for race pack...so full pack and warm motor....lots of possibilities around that.

## Maintenance

A properly maintained machine is safer, faster, and more fun to ride. It is important that you adhere to this maintenance schedule to promote the longevity of your Cobra Motorcycle.

### Tips

1. Cobra Motor Cooling Fluid is the ONLY cooling fluid that is compatible with high voltage electronics and provides the necessary lubrication for the bearings.

**CAUTION:** Coolant designed for Internal Combustion Engines (motor coolant, engine coolant, antifreeze, etc....) is not compatible with the high voltage electronics in the motor and will cause motor faults, potential damage, and an avoidable tech call and down time.

2. New chains will stretch on first use. Never install a new chain prior to a race. Always 'break' them in during practice.
3. Your Cobra Motorcycle has a 10-digit VIN (Vehicle Identification Number). The first three digits indicate the model while the sixth and seventh indicates the model year.
  - a. Example, FWExx17xxx is a 2017 CX50 SR.

4. The frame is 4130 Chrome Moly & HSLA, and it is important to weld it with the proper rod and heat settings set as light as possible. Cobra recommends replacing the frame with a new one if the old one becomes damaged. Use ER70S6 filler if welding on the frame.

## Schedule

- Prior to each ride
  - Chain for proper tension and lubrication
  - Chain 'slider' wear on both chain sliders
  - Insure the smooth operation of the electronic throttle cable.
  - Check for adequate tire pressures and adjust if necessary.
  - Check all nuts and bolts for proper torque and re-torque if necessary.
  - Check the frame for cracks in the metal or cracks in the paint that might indicate that the metal has been stressed beyond its safe limits. Replace or get properly re-welded as necessary.
  - Check the rims for signs of stress; like cracks around the rim, spokes, and hub.
  - Equalize the pressure in the forks with atmosphere. Release any pressure built up inside the fork by loosening the bleed screw on the fork cap. Retightening after pressure is released.
- Every 20 hours of operation
  - Replace the fork oil.
  - Have the shock oil replaced by a Certified Cobra Mechanic.
- Every 50 hours of operation
  - Replace the Motor Cooling Fluid.

# Replacing Motor Cooling Fluid

## Tools needed:

- 8mm Allen wrench
- Minimum of 500 cc (16 oz) *Cobra Motor Cooling Fluid* (Part #MCMUMF32).

## Procedure:

(to be completed)

Youtube videos available: search "CX5e Coolant"

# Proper Chain adjustment

## Tools required for chain adjustment

- 19 mm wrench or socket
  - 13 mm wrench or socket
1. Make sure that the rear wheel is aligned properly.
  2. For proper adjustment, the chain should have 35mm (1.378") free movement just behind the chain guard with no load on the bike (figure 2)

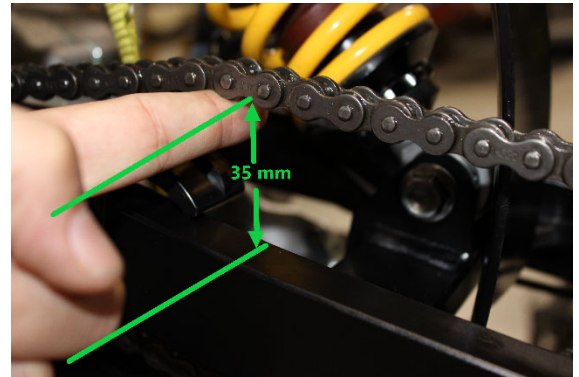
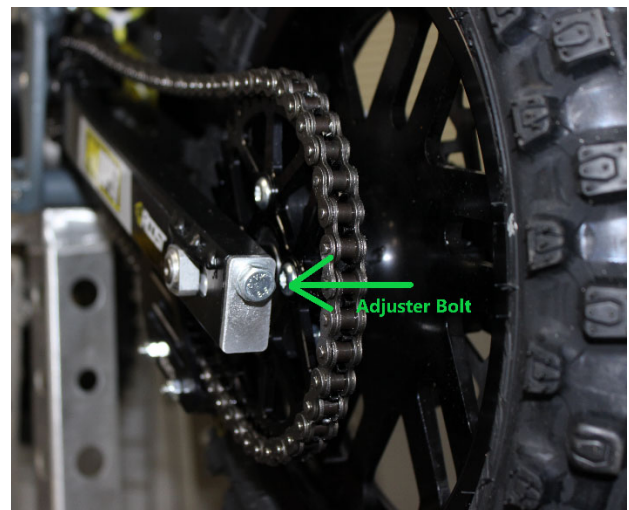

Figure 2

## CAUTION:

Sit on the bike and verify that the chain has a minimum of 12mm (1/2") free movement when the chain is at its tightest point.

3. If the chain requires adjusting, loosen the axle with a 19 mm wrench and tighten the chain by rotating the adjuster bolts clockwise (CW) or loosen the chain by rotating the adjuster bolts (CCW).
4. Ensure proper alignment of the rear wheel by making sure there are equal amounts of the alignment holes (figure 4) showing on each side of the wheel.



5. Retighten the axel bolt to 25 ft-lb (34 Nm).

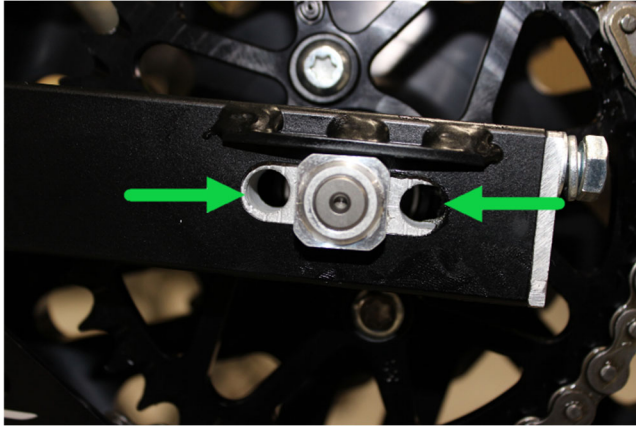

6. Retighten the adjustor bolt (figure 3)

Figure 3 (top), Figure 4 (bottom)



# Rear Brake Pedal Height

Brake pedal toe tip height can be adjusted with the nut and adjuster located below the rear brake master cylinder. The free-play is not adjustable on this model.

**CAUTION:** Use a New container of VP Racing: 622 DOT4 Racing Brake Fluid if necessary to add fluid.

## Setting rear brake pedal position (see figure 2b):

1. Loosen the height adjust lock nut (10mm wrench)
2. Adjust the height adjustment shaft (fingers on the threaded portion of the plunger) to raise or lower
  - a. Standing riding position, and
  - b. Sitting riding position.
3. Tighten the height adjust lock nut.

Lock Nut  
Locking clip on clevis

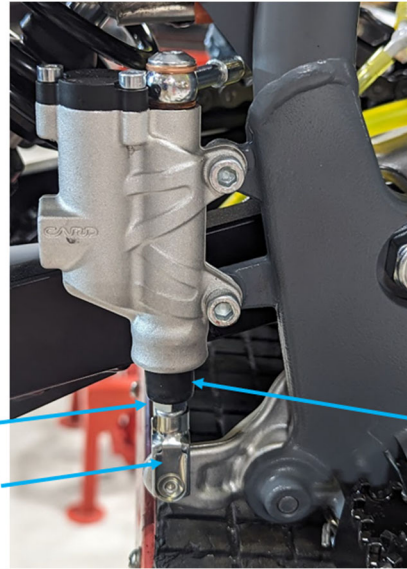

Threaded height adjustment shaft  
Under boot

**Figure 2b**

the pedal:

**NOTE:** If it's not possible to rotate the threaded adjuster by finger, the next way would be to remove the clevis from the brake pedal by popping of the **Locking Clip**, use vice grips or similar on the threaded portion to keep it from rotating, and use a wrench on the square portion of the clevis that remains on the brake plunger

**NOTE:** Turning the clevis Clockwise will lengthen the adjuster (plunger), will raise the toe tip of the brake pedal, and turning the clevis Counter-Clockwise will shorten the adjuster (plunger) lowering the toe tip of the brake pedal.

## **⚠ WARNING**

Make sure that the free play locking clip is installed such that one must push forward, toward the front of the bike, to remove. Otherwise the clip is apt to come undone while riding.

# Fork Maintenance

Cobra strongly recommends that a professional service technician conduct all internal maintenance other than changing springs and oil. This will help to ensure safe and consistent operation.

For routine maintenance, the chart below provides suggested service intervals for common procedures:

	<u><i>Each Ride</i></u>	<u><i>10 hours</i></u>	<u><i>20 hours</i></u>	<u><i>As Needed</i></u>
<u><i>Bleed excess air</i></u>	<u><i>X</i></u>			
<u><i>Change Oil</i></u>		<u><i>X</i></u>		
<u><i>Change Seal/Striper</i></u>			<u><i>X</i></u>	
<u><i>Change Bushings</i></u>				<u><i>X</i></u>

## Fork Air Bleeding

### Tools required

- 3mm hex key (Allen wrench)

During normal operation, both fork legs will build up air pressure. This pressure acts as an additional spring so it must be bled on a regular basis to maintain consistent suspension operation. Before each ride, loosen the socket head cap screw located at the front of each fork cap far enough so that any excess pressure in the leg is relieved. After excess air is bled off, retighten the screw to 5 in-lb. Be careful not to lose or damage the sealing ring that is located under the head of each bleed screw.

## Fork Oil Replacement

### Tools required

- 32mm Fork Cap Tool (MCMUTL32)
- 8mm Allen wrench
- 4 & 5 mm hex key (Allen wrench)
- 9/16 wrench
- Mallet
- 5 wt. VP fork oil

# Disassembly procedure

1. Remove the front wheel and axle (8mm Allen wrench).
2. Remove brake line clamp.
3. Remove the brake caliper from the fork leg (4mm hex key).
4. Loosen the top pinch bolts (6mm hex key).
5. Loosen the fork caps (32mm fork cap tool).
6. Loosen the bottom pinch bolts (5mm hex key).
7. Remove the fork legs from the triple clamps (5 and 8mm hex key).
8. One leg at a time
  - a. Remove the fork cap from the fork tube.
  - b. Pull the fork spring down to gain access to the fork cap jam nut and secure it with a 9/16 wrench.
  - c. Holding in one hand the 9/16 wrench use the fork cap wrench to unscrew the fork cap from the damper rod.
  - d. Remove the fork spring pad, and fork spring.
  - e. Inside the damper rod, the rebound adjustment screw pin is resting and will fall out of the damper rod when the fork is inverted. Try to catch it before it falls into your oil bucket.
  - f. Invert the fork and allow the oil to drain completely. Working the damper rod up and down will speed up the draining process.

## Assembly procedure

1. Fill the fork with 150ml of fork oil.
2. Work the damper rod up and down to allow the fork cartridge to fill with oil.
3. Install the rebound adjustment screw pin into the damper rod.
4. Install the fork spring and spring pad.
5. Extend the damper rod completely and Compress the fork spring enough to begin threading the fork cap back onto the damper rod.
6. Make sure that the fork cap threads onto the damper rod completely before it makes contact with the jamnut.
7. Tighten the jamnut.
8. Tighten the fork cap to the fork leg outer
9. Install each leg back into the triple clamp. Torque each pinch bolt to 14N-m (10.3 ft-lb) making sure both legs are set to the same height in the clamps.
10. Pump the fork leg several times to verify that it operates smoothly.
11. Reinstall the brake caliper.
12. Reinstall the front wheel (25 ft-lb, 34 Nm).

# Parts – Bars and Controls

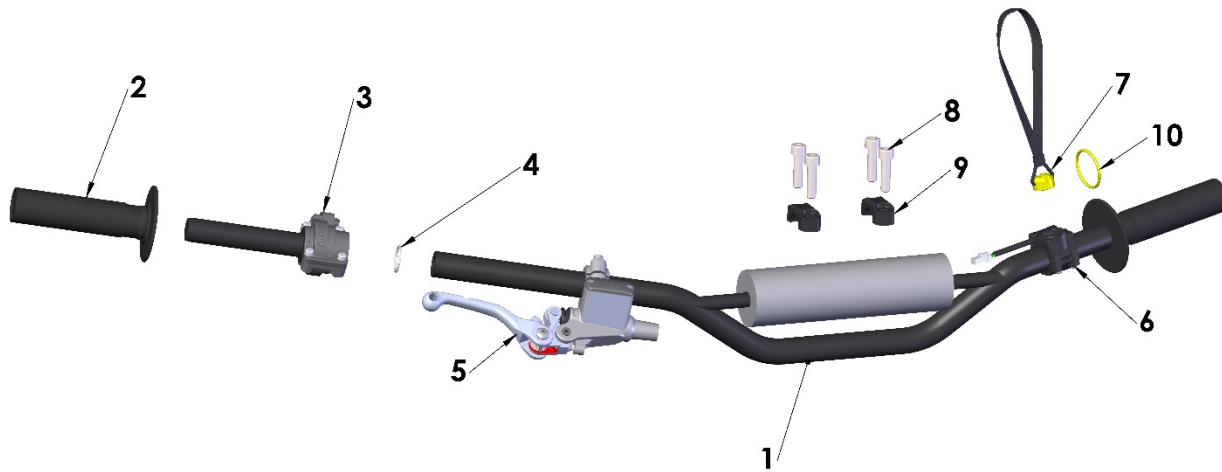

Bars and Controls		
REF #	PART #	DESCRIPTION
1	FAMU0017	HANDLEBAS – MICROBARS – COBRA BEND
2	TCMU0021	GRIPS (SET OF TWO) – MICROGRIPS
3	JACE50006MP	THROTTLE ASSEMBLY – TWIG - ELECTRONIC
3A	HCBC0412	M4x12 SHSC
4	FCMU0041	STOP RING – MICRO BAR THROTTLE
5		SEE FRONT BRAKE
6	NCCEMU001MP	KILL SWITCH ASSEMBLY - MAGNETIC
7	NCCEMU005	KEY – YELLOW – RACER - KILL SWITCH ACTIVATE
8	HCBC0806	M8X30mm SOCKET HEAD CAP SCREW (4 REQ'D)
9	TCMU0060BLK	BAR CLAMP – BLACK (2 REQ'D)
10	ZCMUOR08	O-RING – KEY RETAINER
ACCESSORY	MCMUAM11	GRIP DONUT – PAIR – PRO TAPER MICRO BAR
ACCESSORY	FKMU0004	HANDLEBAR KIT- PRO TAPER MICRO- WITH COBRA THROTTLE AND GRIPS
ACCESSORY	TKMU00002BLK	BAR RISER KIT

# Parts – Battery

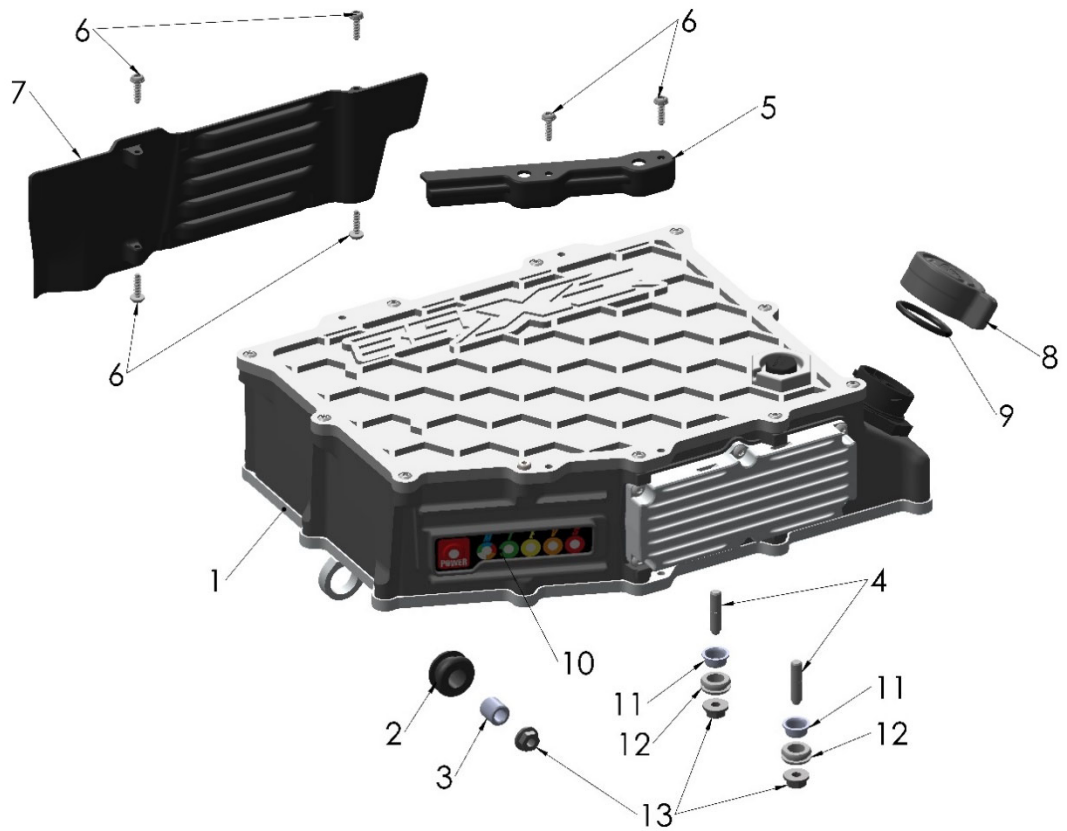

Battery		
REF #	PART #	DESCRIPTION
1	DACE10001MP	BATTERY ASSY – 1.0 kWh – 48V & MOUNTING HARDWARE
2	DCCE10010	GROMMET – REAR BATTERY MOUNT 1kWh
3	DCCE10009	COMP LIMITER – REAR BATTERY MOUNT 1kWh
4	DCCE10006	STUD – FRONT BATTERY MOUNTING
5	DCCE10012	SHIELD – BATTERY EDGE – RIGHT SIDE
6	HCTF0416	M4X16MM THREAD FORMING SCREW FOR PLASTIC
7	DCCE10013	SHIELD – BATTERY EDGE – LEFT SIDE
8	DCCEMU001	BLOCK OFF – CONNECTOR – BATTERY
9	ZCCEMUOR4	O’RING – BATTERY BLOCK OFF CAP
10	DCCE10005	OVERLAY – BATTERY USER INTERFACE
11	DCCE10008	COMPRESSION LIMITER – FRONT BATTERY MOUNT
12	DCCE10007	GROMMET – FRONT BATTERY MOUNT
13	HCNW0601	6MM SPINNING WASHER NUT – 19MM OD (3 REQ'D)

## Chargers:

Low Power 48/50V: DAMU0003  
 High Power 48/50V: DAMU0002

# Parts – Electrical System

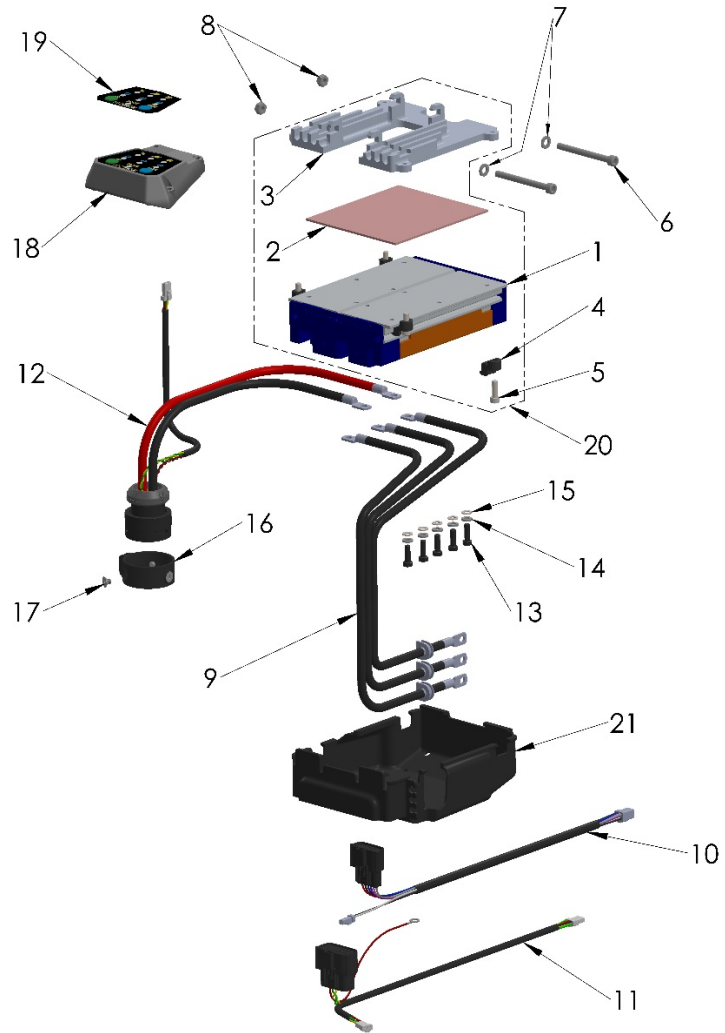

Electrical System		
REF #	PART #	DESCRIPTION
1	JCCE50003	CONTROLLER – MOTOR
2	NCMU0001	THERMAL PAD – HEAT SINK TO CONTROLLER
3	FCCE3001	MOUNT – CONTROLLER
4	FCCE50019	CLAMP – CONTROLLER MOUNT (4 PCS)
5	HCBC0516	M5X16MM SHCS or HCBF0516 SELF TAPPER (depends if socket head cap screw or hex head with flange)
6	HCBC0665	M6X65MM SHCS
7	HCWF0601	M6 FLAT WASHER (4 REQ'D)
8	HCNL0601	M6 NYLOCK NUT
9	JCCE3002MP	MDU PHASE WIRE, WITH TERMINATIONS – CX3E ONLY
10	JCCE3003	HARNESS - HALL SENSORS – CX3E ONLY
11	JCCE3004	HARNESS – CAN / COMMUNICATION - JST
12	JCCE1001MP	POWER LEADS FOR MDU
13	HCBH0501	M5X12MM HEX HEAD BOLT(5 PCS)
14	HCWF0501	M5 LOCK WASHER (5 PCS)
15	HCWL0501	M5 FLAT WASHER (5 PCS)
16	TCCE50005	HELPER – BATTERY CONNECTION
17		#10-32 FLAT HEAD SCREW - SHORT
18	VACEMU001MP	RDU – RIDER DISPLAY UNIT
19	VCCEMU004	OVERLAY - RDU
20	JACE50007	CONTROLLER ASSY - WITH PAD ON MOUNT
21	FCCE3004	COVER – CONTROLLER – CXE3

# Parts – Electronics Box

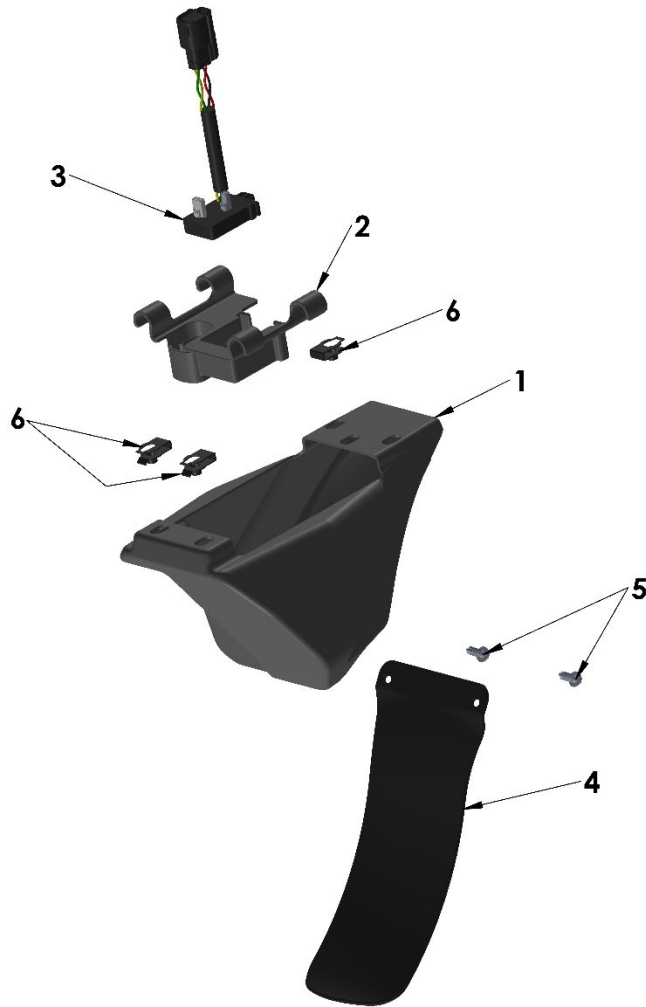

Air Box		
REF #	PART #	DESCRIPTION
1	TCCE30002	ELECTRONICS BOX
2	JCCE3005	ELECTRONICS HANGER – 3E
3	JCCE50064	CAN NETWORK NODE MODULE W/ DIAGNOSTIC PORT (CNN Module) – JST
4	TCC60008	MUDFLAP
5	HCSP0004	PLASTIC SCREW
6	HCHA0003	M6 CLIP NUT

# Parts – Forks & Triple Clamps

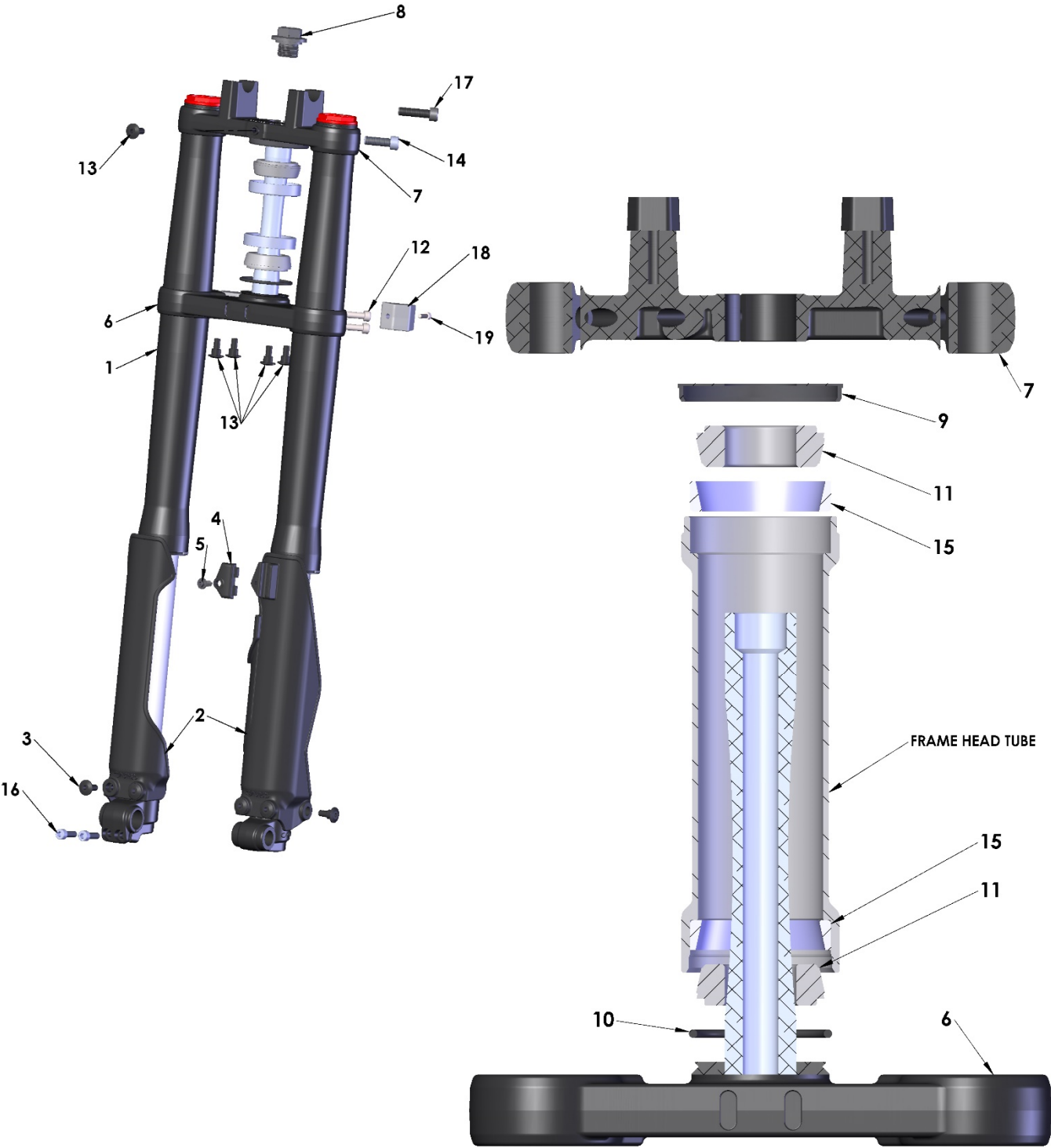



Front Forks and Triple Clamp		
REF #	PART #	DESCRIPTION
1	KACE32025	FORK COMPLETE, BRAKE & NON-BRAKE SIDE
2	KCMU0035	FORK GUARD SET – 2021
3	HCSP0610BLK	BOLT - FORK GUARD - BLACK (6 REQ'D,)
4	KCMU0036	BRAKELINE CLAMP
5	HCSP0004	PLASTIC SCREW (2 REQ'D)
6	FAMU0020BLK	TRIPLE CLAMP BOTTOM ASSY, (CLAMP & STEM) BLACK
7	FCMU0071BLK	TRIPLE CLAMP TOP - BLACK
8	FCMU0074	BOLT – STEERING STEM
9	FCMU0079	DUST COVER (1 REQ'D)
10	FCMU0044	O-RING (1 REQ'D)
11	FCMU0004	STEERING HEAD BEARING (2 REQ'D)
12	HCBC0625	M6X25mm SOCKET HEAD CAP SCREW
13	HCSP0610BLK	BOLT - FORK GUARD - BLACK (NUMBER PLATE & FENDER)
14	HCBC0825	M8 x 25mm SOCKET HEAD CAP SCREW
15	FCMU0011	RACE – STEERING STEM BEARING (2 REQ'D)
16	HCBC0620	M6X20MM SOCKET HEAD CAP SCREW (2 REQ'D)
17	HCBC0806	M8x 30 SHCS
18	FCMU0175MP	STEERING STOP BUMPER (2 REQ'D)
19	HCBB1416	M4x 16 BUTTON HEAD (2 REQ'D)
ACCESSORY	FKMU0008	KIT – STEERING STEM BEARINGS, RACES AND SEALS
TOOL	MCMUTL44	TOOL – BEARING AND SEAL INSTALLER ASSY

# Parts – Forks – Leg Assembly – Both Sides

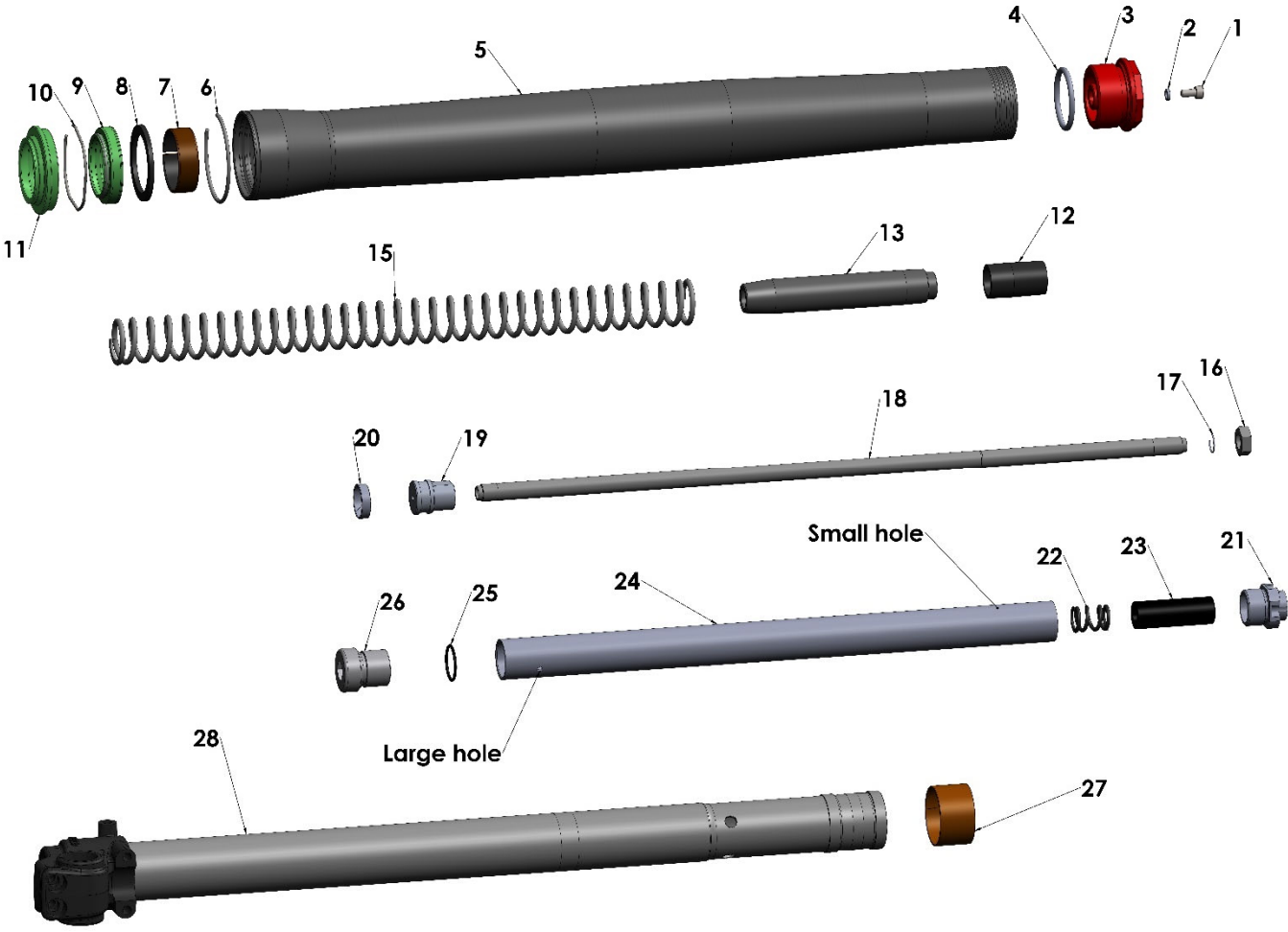

# Parts – Forks – Leg Assembly – Brake Side

REF #	PART #	DESCRIPTION
1	HCBC0408	4 X 8 SHCS CLEAR ZINC
2	ZCKG0001	GASKET, BLEED SCREW FORK
3	KCCL0001	FORK CAP - CONVENTIONAL 32MM USD
4	ZCMUOR18	O-RING – 3mm x 27mm ID
5	KCCS0005	FORK - OUTER TUBE 32MM
6	KCCS0035	RING CLIP FORK OUTER WEAR RING 32MM
7	KCCS0006	FORK GLIDE RING BOTTOM 32MM
8	KCCS0032	FORK SEAL SPACER 32MM
9	KKCS0004	FORK SEAL AND SWIPER KIT 32MM
10	KCCS0002	RING CLIP - FORK SEAL RETAINER - 32MM
11	KKCS0004	FORK SEAL AND SWIPER KIT 32MM
12	KCC60067	FORK JOUNCE BUMPER
13	KCCS0013	FORK SPRING GUIDE 32MM
14	KCCL0002	SPACER – SPRING GUIDE EXTEND
15	KCCJ3221	STANDARD SPRING - FORK 0.21 KG/MM 32mm
15	KCCJ3218	LIGHT SPRING - FORK 0.18 KG/MM 32mm
15	KCCJ3225	HEAVY SPRING - FORK 0.25 KG/MM 32mm
16	HCNJ3824	NUT JAM 3/8-24 CLASS 8
17	KCC60068	RING CLIP - FORK SPRING GUIDE RETAINER
18	KCMU0024	TUBE - DAMPER
19	KCCL0003	CAP WITH PISTON – DAMPER
20	KCCS0018	GLIDE RING – MID VALVE PISTON
21	KCMU0013	CARTRIDGE CAP
22	KCKG0050	TOP OUT SPRING
23	KCCJ0002	TRAVEL LIMITER SPACER
24	KCCE3001	CARTRIDGE TUBE – E3
25	ZCKGB017	O’RING – BOTTOM PLUG
26	KCC60057	PLUG – BOTTOM – NON ADJUSTABLE
27	KCCS0007	FORK GLIDE RING
28	KAMU0003BLK	FORK LOWER – COMPLETE – BRAKE SIDE
28	KAMU0004BLK	FORK LOWER – COMPLETE – NON-BRAKE SIDE
<b>TOOL</b>	<b>MCMUTL39</b>	<b>TOOL – FORK SEAL / SWIPER DRIVER – 32MM</b>
<b>TOOL</b>	<b>MCMUTL32</b>	<b>TOOL – FORK CAP WRENCH – 32MM</b>
<b>TOOL</b>	<b>MCMUTL04</b>	<b>TOOL – CARTRIDGE TUBE WRENCH</b>

# Parts – Frame & Subframe

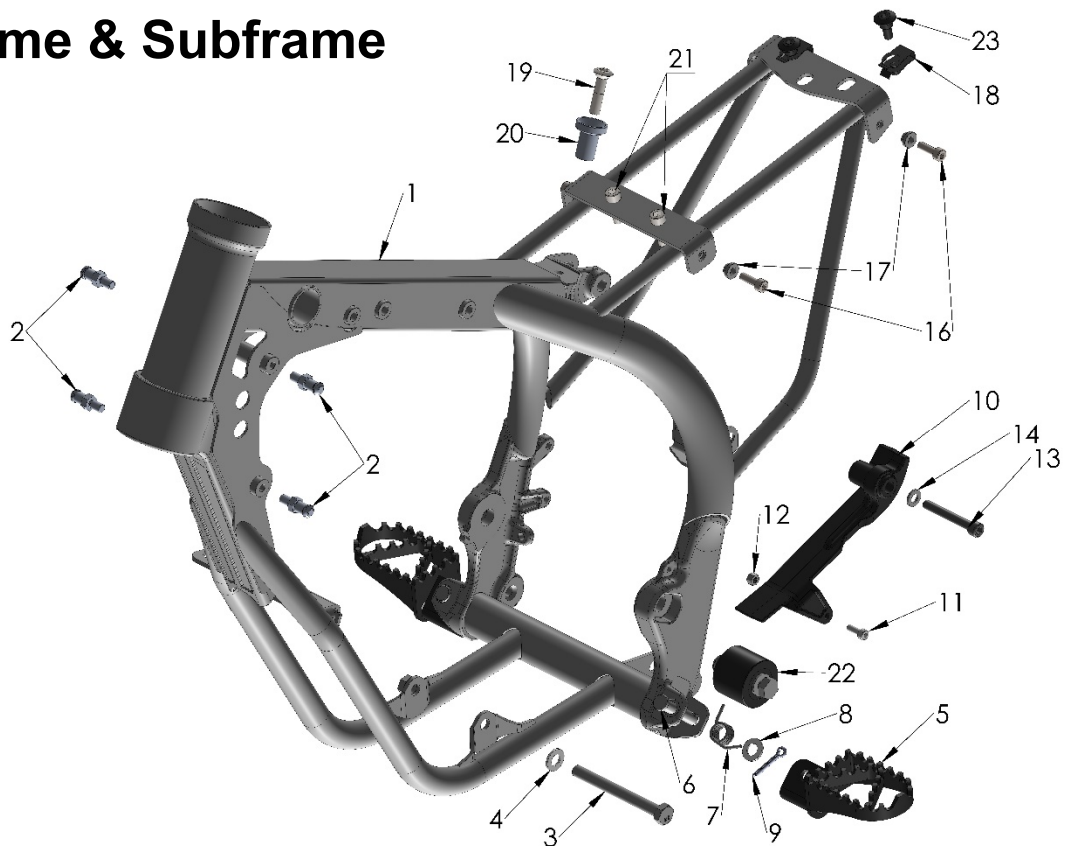

Frame		
REF #	PART #	DESCRIPTION
1	FACE32025	FRAME – CX3E - 2025
2	FCCE50015	POST – SIDE LOUVER
3	HCBH0880	M8 x 80 HEX HEAD BOLT
4	HCWF0801	8mm FLAT WASHER – MOTOR MOUNT BOLT
5	TCMU0139	FOOTPEGS (PAIR)
6	FCMU0031	CLEVIS PIN - FOOTPEG
7	TCC60012	SPRING - FOOTPEG (SINGLE PIECE)
8	HCWF0801	8mm FLAT WASHER
9	HCCP0008	COTTER PIN 1/8 X 3/4
10	FCCEMU001	CHAIN SLIDER – MOLDED - UPPER
11	HCBC0412	M4x 12 SHCS
12	HCNL0401	M4 NYLOCK NUT
13	HCBC0606	M6x 45 SHCS
14	HCWF0601	M6 FLAT WASHER
15		
16	HCBC0516	M5x 16 SHCS
17	TCC60017	5mm BODY PANEL WASHER
18	HCHA0003	6mm CLIP NUT
19	HCSP0701	M7 SPROCKET BOLT
20	TCMU0068	REAR TANK AND SEAT MOUNT
21	HCBC0620	M6x 20mm SHCS
22	FCC60020	CHAIN ROLLER WITH HARDWARE
23	HCSP0610	FENDER MOUNTING FASTENER

# Parts – Front Brakes

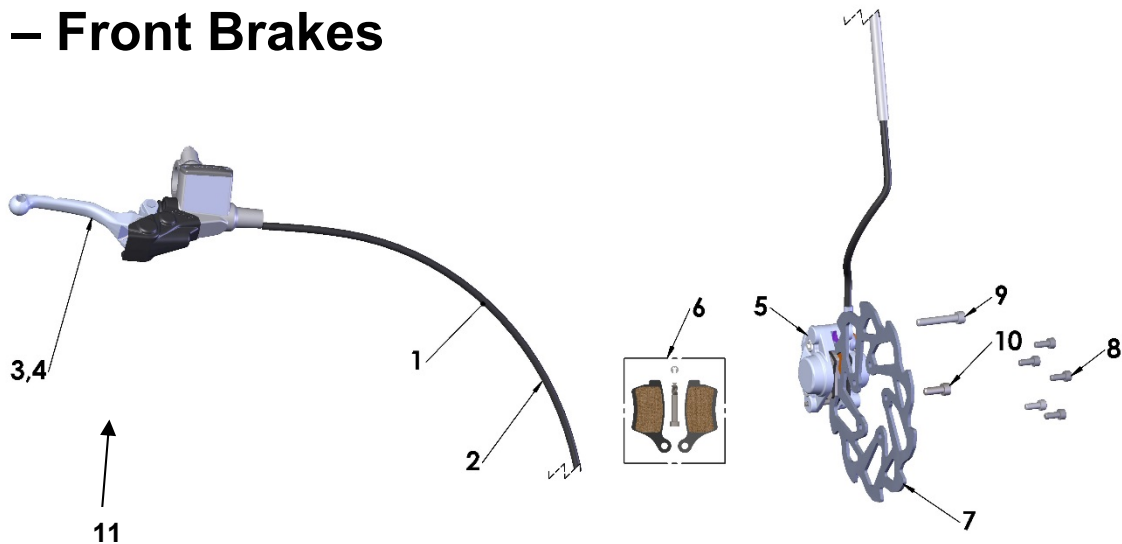

Front Brakes		
REF#	PART #	DESCRIPTION
1	BACJ0005	BRAKE ASSY – FRONT CARD – JR/P3
2	BCCJ0004	HOSE – BRAKE FRONT
3	BAMU0009	LEVER ASSEMBLY – THIN FORMLY
4	BAMU0006	MASTER CYLINDER ASSEMBLY 11.0 CARD
5	BAMU0020	CALIPER – FRONT – CARD 2 PISTON
6	BKMU0009	KIT 505 ORGANIC BRAKE PADS, WITH BOLT AND CLIP
7	BCMU0222	BRAKE ROTOR
8	HCBC0514	M5X14mm SOCKET HEAD CAP SCREW (5 REQ'D)
9	HCBC0635	M6X35mm SOCKET HEAD CAP SCREW
10	HCBC0620	M6X20mm SOCKET HEAD CAP SCREW
11	BCMU0116	COVER – MUD PROTECTION
Caliper Accessories		
ACCESSORY	BKMU0003	BLEED KIT (MULTIPLE SYRINGES, FITTINGS & HOSE)
ACCESSORY	BCMU0038	SPRING - BRAKE PAD RETURN
ACCESSORY	BKMU0006A	PISTON & SEAL KIT – CARD - ALUMINUM
ACCESSORY	BKMU0008	BLEED SCREW KIT – CARD
ACCESSORY	BKMU0007	BANJO BOLT AND WASHER KIT – CARD
ACCESSORY	BCMU0014	CALIPER ADJUSTMENT SHIMS 6mm ID
Master Cylinder Accessories		
ACCESSORY	BKC60008	CAP & BLADDER KIT ZL150 (CAP, BLADDER & (2) M3-0.5 X 6mm LONG PHILLIPS SCREW)
ACCESSORY	BCC60058	CLAMP – M/C ZL150
ACCESSORY	HCBC0620	M6-1.0 X 22mm SOCKET HEAD CAP SCREW
ACCESSORY	BCMU0060	PIVOT BOLT
ACCESSORY	BCC60017	BOOT – PISTON END COVER
ACCESSORY	BKC60015	REBUILD KIT – MASTER CYLINDER CARD 11.0 mm (PISTON, SEALS, BUSHING, SPRING, CLIP & RETAINING WASHER)
ACCESSORY	HCSS0520	M5 X 20 SET SCREW – LEVER POSITION ADJUSTMENT
ACCESSORY	HCNJ0501	5MM LOCKNUT
ACCESSORY	CKC60005	PIVOT BOLT KIT – LEVER TO PIVOT BLOCK – MALE & FEMALE
ACCESSORY	HCSS0610	SET SCREW – PRESET
ACCESSORY	BCMU0059	LEVER ONLY – THIN FORMLY
ACCESSORY	CCC60026	SPRING – LEVER RETURN
ACCESSORY	CCC60025	SPACER – SPRING CENTERING

# Parts – Front Wheel

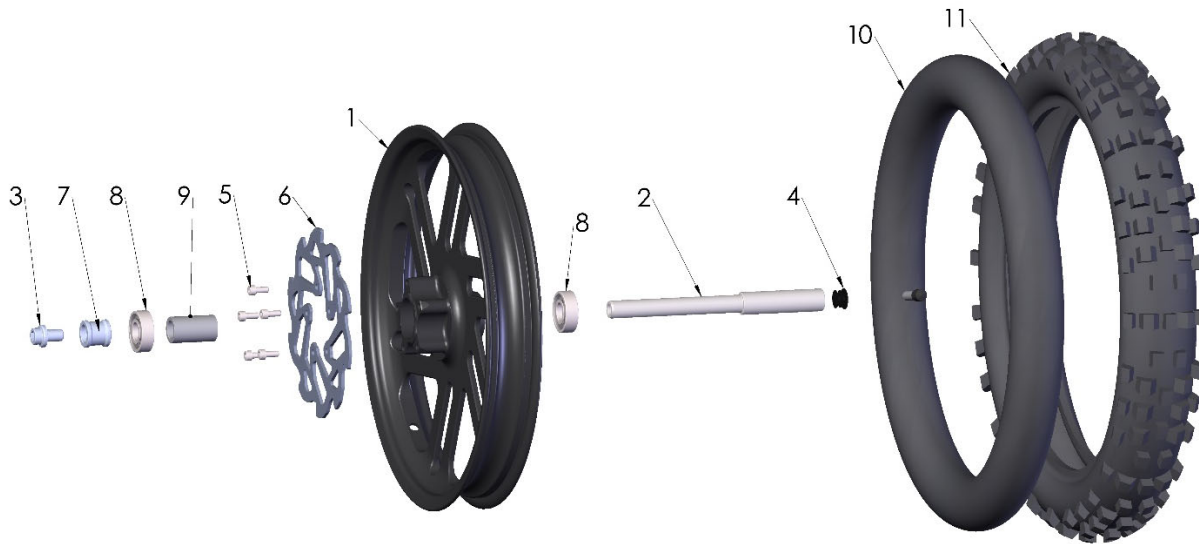

Front Wheel		
REF #	PART #	DESCRIPTION
1	WAMUF021BLK	WHEEL WITH BEARINGS SPOKE STYLE – BLACK ANODIZE
2	WCMU0043	FRONT AXLE - HOLLOW
3	HCSP1016M	BOLT – ALUMINUM AXLE PULL
4	WCMU0024	PLUG - BLACK PLASTIC
5	HCBC0514	M5X14mm SOCKET HEAD CAP SCREW (5 REQ'D)
6	BCMU0222	BRAKE ROTOR – FRONT & REAR
7	WCMU0045	WHEEL SPACER LEFT
8	WCMU0120	BEARING – WHEEL (2 REQ'D)
9	WCMU0044	SPACER – WHEEL FRONT
10	WCMUTU10	TUBE 10"
11	WCMU1050D34	TIRE - FRONT - 60/100-10 - DUNLOP MX34

# Parts – Motor System - Internals

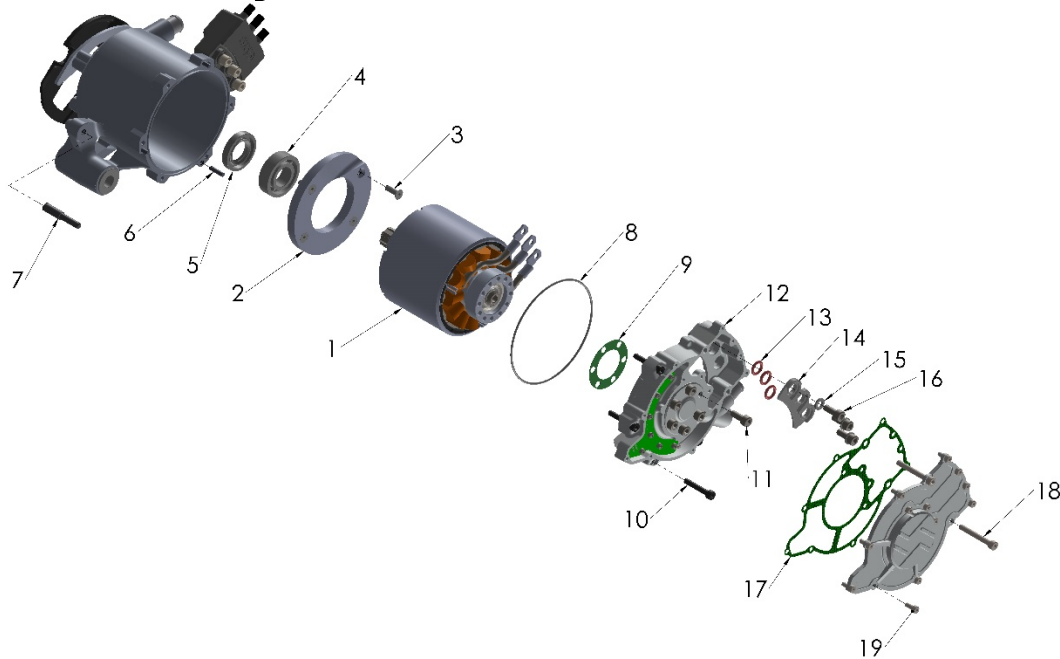

Motor System		
REF #	PART #	DESCRIPTION
1		MOTOR - NOT SOLD SEPARATELY
2	JCCE50038	STUFFER – PUMP
3	HCFH0516	M5X16MM FLAT HEAD SCREW (4 REQ'D)
4	ECKGBR01	BEARING – OUTPUT
5	JCCE50031	SEAL - OUTPUT
6	ECDC0051	DOWEL PIN 4X16 (3 REQ'D)
7	DCCE10011	STUD – REAR BATTERY MOUNT – M8 / M6
	ECC60107	STUD – REAR BATTERY MOUNTING M6
8	ZCCE50R03	O’RING – CASE SEALING
9	ZCCE50002	GASKET – STATOR TUBE TO CASE
10	HCBC0504	M5X40MM SHCS (2 REQ'D)
11	HCBC0503	M5X30MM SHCS (4 REQ'D)
12	JCCEMU001	HOUSING – MOTOR – WIRE SIDE
13	ZCCEMUOR1	ORING – PHASE STUDS
14	JCCE50037	INSULATOR – PHASE
15	HCWF0601	M6 FLAT WASHER (3 REQ'D)
16	HCBC0601	M6X16MM SHCS (3 REQ'D)
17	ZCCEMU001	GASKET – PHASE COVER TO CASE
18	HCBC0504	M5X40MM SHCS (2 REQ'D)
19	HCBC0410	M4X10 SHCS (9 REQ'D)
	HCBC0408	M4X8 SHCS (4 REQ'D) IN THE CENTER
	See Rear Brake	BRAKE SNAKE ON BRACKET
ACCY	MCMUMF32	MOTOR COOLING FLUID – 32OZ BOTTLE

# Parts – Motor System – Sprocket Side

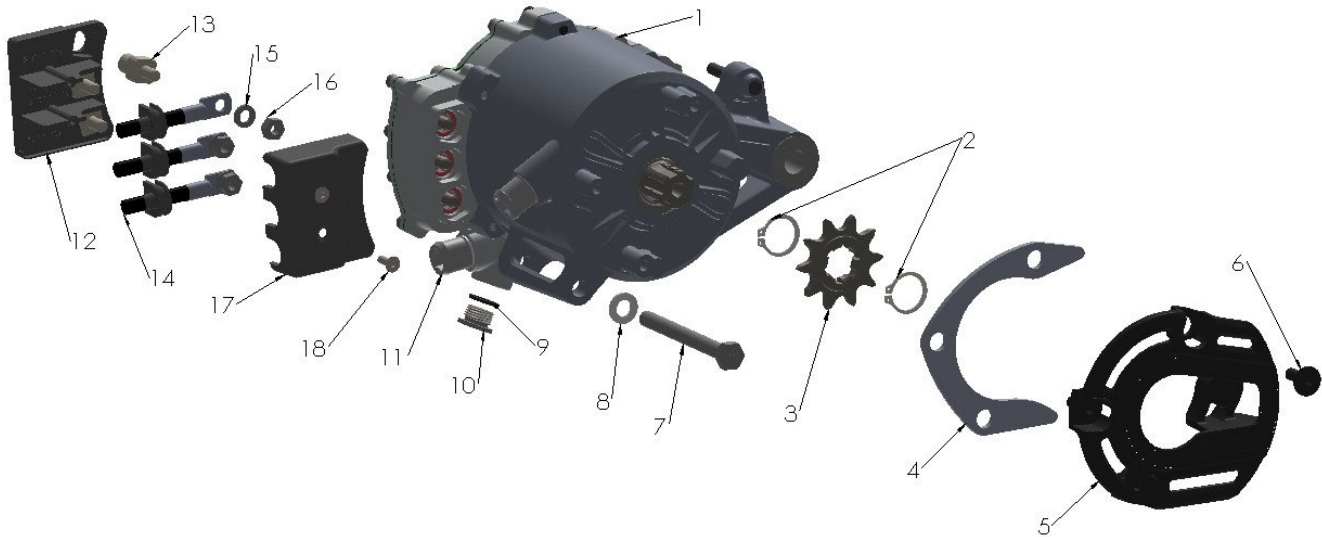

Motor System		
REF #	PART #	DESCRIPTION
1	JACEMU002	MOTOR ASSEMBLY – COBRA – SMALL VEHICLE
2	ECKGSR03	SNAP RING – OUTPUT SHAFT (2 REQ'D)
3	PCMU0010	SPROCKET – FRONT – 10T – 415 CHAIN
4	JCCEMU005	GUARD – MOTOR CASE SAVER
5	JCCEMU023	GUARD – SPROCKET - 2025
6	HCSP0610BLK	BOLT – FORK GUARD – 6MM ALUM – BLACK (3 REQ'D)
7	HCBH0880	M8 X 80MM HEX HEAD
8	HCWF0801	8MM FLAT WASHER
9	ZCMUB014	O’RING – COOLANT DRAIN
10	ECMU0272	PLUG – COOLANT DRAIN
11	ECMU0132	FITTING - COOLANT
12	JCCE50036	SPACER – INSULATING – PHASE LEADS
13	JCCE50035	STUD – PHASE – RING LUG STYLE (3 REQ'D)
14	SEE ELECTRICAL	PHASE LEADS
15	HCWF0601	6MM FLAT WASHER (3 REQ'D)
16	HCNS0601	M6 NUT DIN 934 CLASS 8
17	JCCE50044	CAP – SPACER – PHASE LEAD INSULATING
18	HCFH0412	M4 X 12MM FLAT HEAD (2 REQ'D)
19		
ACCY	MCMUMF32	MOTOR COOLING FLUID – 32OZ BOTTLE



# Parts – Motor System – Wire Side

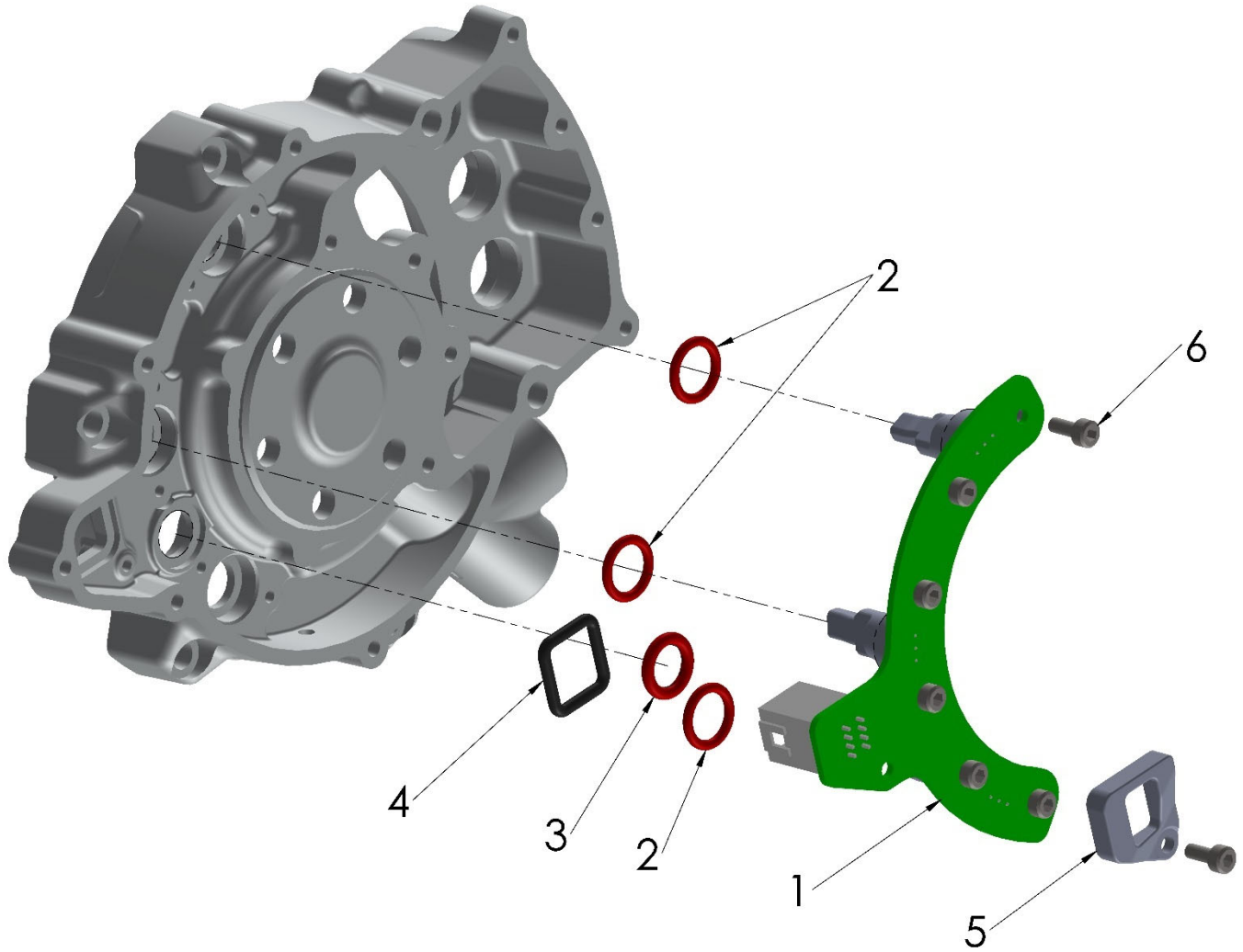

Motor System		
REF #	PART #	DESCRIPTION
1	JCCEMU017	MOTOR SENSOR MODULE V2 – HALL HUB – SMALL VEHICLE
2	ZCCEMUOR5	O’RING- V2 – MOTOR HOUSING (3 REQ’D)
3	ZCCEMUOR2	O’RING – TEMP SENSOR PASS THRU
4	ZCCEMUOR3	O’RING – JST CONNECTOR PASS THRU
5	JCCEMU007	PRESSURE PLATE – HALL SENSOR BOARD
6	HCBC0308	M3X8MM SHCS (7 REQ’D)
ACCY	MCMUMF32	MOTOR COOLING FLUID – 32OZ BOTTLE

# Parts – Plastic Bodywork & Seat - E3

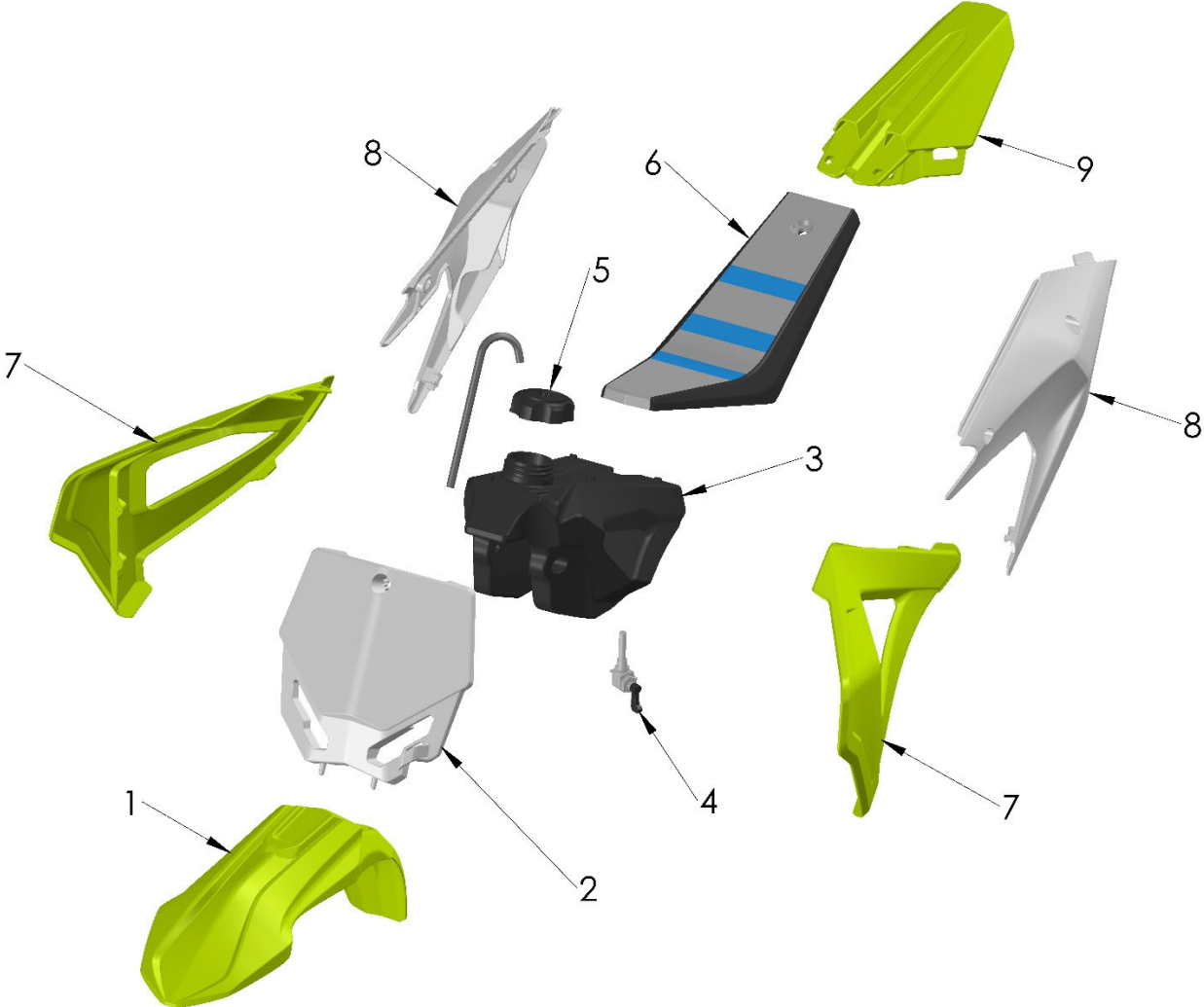

# Parts – Plastic Bodywork & Seat – E3

Plastic and Seat		
REF #	PART #	DESCRIPTION
1	TCCS0009FXX	FRONT FENDER – FLO YELLOW
1	TCCS0009x	FRONT FENDER x – DENOTES COLOR BLK, WHT, YEL, FLO
1A	HCSP0610	FRONT FENDER MTG BOLTS (4 REQD)
2	TCMU0041W	FRONT NUMBER PLATE – WHITE
2	TCMU0041x	FRONT NUMBER PLATE x – DENOTES COLOR BLK, WHT, YEL
2A	HCSP0610	FRONT NUMBER PLATE MOUNTING BOLT
3	TCCJ0012	FUEL TANK – BLACK - (NO PETCOCK OR CAP)
3A	TCMU0047	FRONT TANK MOUNT BUSHING
3B	TCMU0017	FRONT TANK MOUNT BUSHING – SQUARE THREADED
3C	TCC60029	SPACER – SEAT MOUNT
3D	HCFH0620	M6X20mm FLAT HEAD – FRONT SEAT MOUNT
3E	HCFH0675	M6X75mm FLAT HEAD SCREW
4	TCMU0151	PETCOCK
5	TCHA0002	CAP – FUEL TANK
5A	TCHA0003	HOSE – FUEL CAP
6	TACS2025	SEAT – KING CX50 – FLAT BAK
6A	TCCS0018	COVER – SEAT – KING CX50 – FLAT BAK
6B	TCMU0046BLK	SPECIAL WASHER – SEAT HOLDING – BLACK
6C	HCFH0650	M6X50 FLAT HEAD, REAR MOUNTING BOLT
7	TCMU0043FXX	SHROUD – MEGA FLO YELLOW
7	TCMU0043x	SHROUD LEFT x – DENOTES COLOR BLK, WHT, YEL, FLO
7A	HCSP0004	PLASCREW – SHROUD TO TANK (4 REQ'D)
8	TCMU0065WHT	NUMBER PLATE PAIR – WHITE
8	TCMU0065x	NUMBER PLATE PAIR x – DENOTES COLOR BLK, WHT, YEL
8A	HCBC0502	M5X20 SOCKET HEAD CAP SCREW (2 REQ'D PER SIDE)
8B	TCC60017	BODY PANEL WASHER 5MM (2 REQ'D PER SIDE)
8C	HCCN0000	5MM EXTRUDED “U” NUT
9	TCMU0055FXX	REAR FENDER – MEGA FLO YELLOW – FLAT BAK SEAT
9	TCMU0055x	REAR FENDER x – DENOTES COLOR BLK, WHT, YEL, FLO
9A	HCSP0610BLK	BOLT – SPECIAL
9B	HCHA0003	CLIP NUT – 6mm
10	KCMU0035	FORK GUARD SET – 2021
10A	HCSP0610BLK	BOLT - FORK GUARD - BLACK (6 REQ'D,)
11	KCMU0036	BRAKELINE CLAMP
ACC'Y	TCCJ2025	GRAPHIC KIT
ACC'Y	TKCJ2025	BODYWORK KIT - JR – FXX W WHITE NUMBER PLATES
ACC'Y	TKCJ2025FXX	BODYWORK KIT - JR - FXX
ACC'Y	TKCJ2025BLK	BODYWORK KIT - JR - BLACK
ACC'Y	TKCJ2025WHT	BODYWORK KIT - JR - WHITE

# Parts – Rear Brake

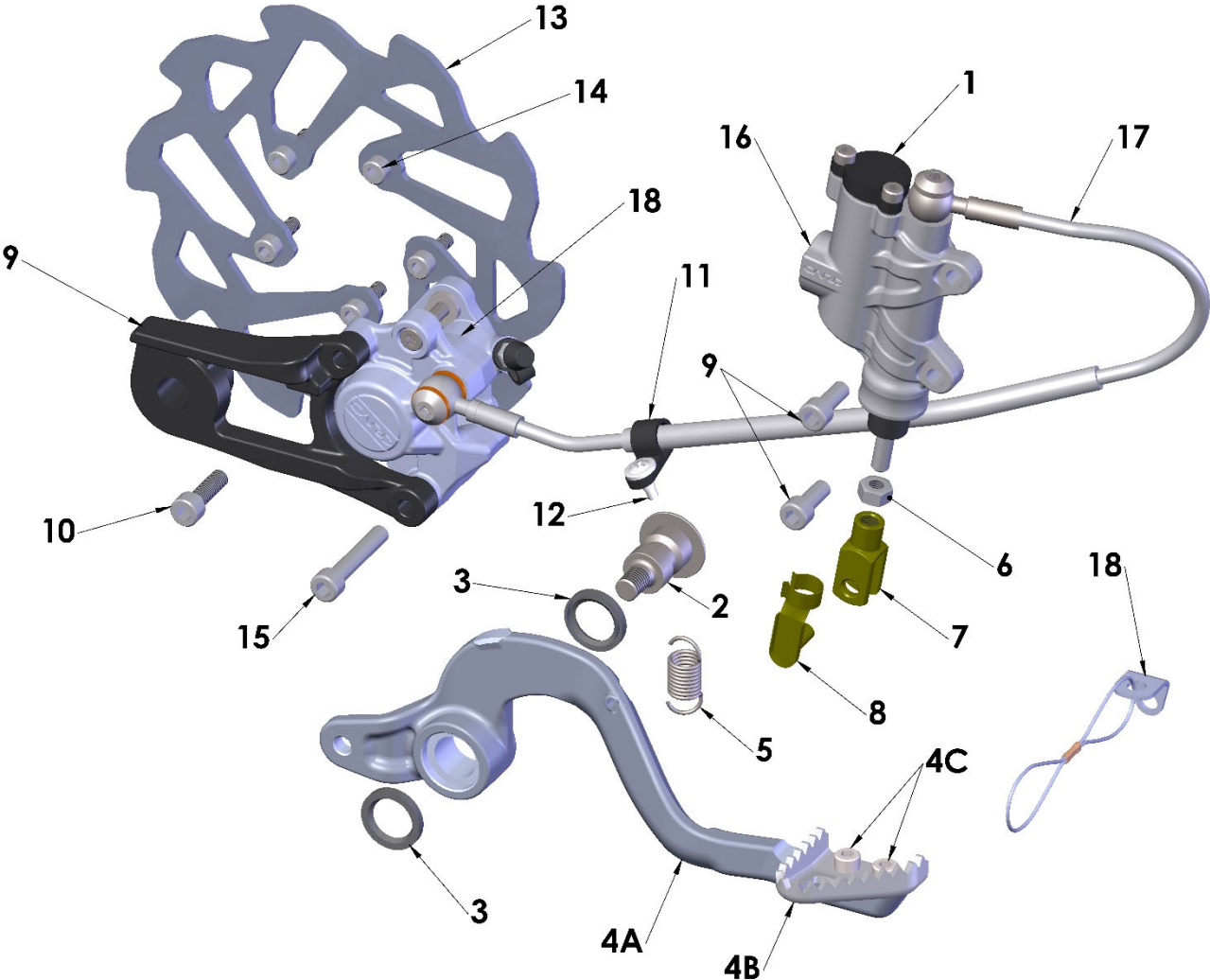

# Parts – Rear Brake

Rear Brake System		
REF #	PART #	DESCRIPTION
1	BACJ0004	<b>BRAKE SYSTEM – REAR (M/C-LINE-CALIPER)</b>
2	BCMU0027	BRAKE PIVOT BOLT – CAPTURED CLEVIS
3	BCMU0501	SEAL – BRAKE PEDAL (2 REQ'D)
4A	BCMU0069	BRAKE PEDAL – ASSEMBLY 50cc – WITH TOE PIECE
4B	BCMU0023T	TOE PIECE
4C	HCBC0512	M5X 12mm SOCKET HEAD CAP SCREW
5	BCMUSP01	BRAKE RETURN SPRING
6	BCMU0015A	BRAKE CLEVIS
7	BCMU0015B	BRAKE RETAINING SPRING PIN
8	BCMU0045BLK	BRAKE CARRIER – CARD 2 PISTON – CX50 – BLACK
9	HCBC0620	M6X20mm SOCKET HEAD CAP SCREW
10	HCCC0000	BRAKE HOSE CLAMP
11	HCPP0832	BRAKE HOSE CLAMP FASTENER
12	BCMU0222	BRAKE ROTOR
13	HCBC0514	M5X14mm SOCKET HEAD CAP SCREWS (5 REQ'D)
14	HCBF0635	M6X35mm SOCKET HEAD CAP SCREW
15	BAMU0014	MASTER CYLINDER - REAR
16	BCMU0061B	REPLACEMENT BRAKE HOSE – JR – E3
17	BAMU0010A	CALIPER ASSEMBLY – REAR BRAKE – CARD 2 PISTON - ALUM
18	BKMU0002	ASSY – BRAKE SNAKE
ACCESSORY	BKMU0009	PAD SET ORGANIC W BOLT AND CLIP
ACCESSORY	BCMU0038	SPRING - BRAKE PAD RETURN
ACCESSORY	BKMU0006A	PISTON & SEAL KIT – CARD - ALUMINUM
ACCESSORY	BKMU0008	BLEED SCREW KIT – CARD
ACCESSORY	BCC60034	RUBBER CAP ONLY - BLEED SCREW
ACCESSORY	BKMU0013	CAP & DIAPHRAGM KIT – MASTER CYLINDER
ACCESSORY	BKMU0014	REBUILD KIT - REAR - MASTER CYLINDER - 2024 - CAPTURED
ACCESSORY	BKMU0007	BANJO BOLT AND WASHER KIT – CARD
ACCESSORY	BCMU0014	CALIPER ADJUSTMENT SHIMS 6mm ID
TOOL	BKMU0003	BLEEDING KIT – FORMULA & CARD

# Parts – Rear Wheel

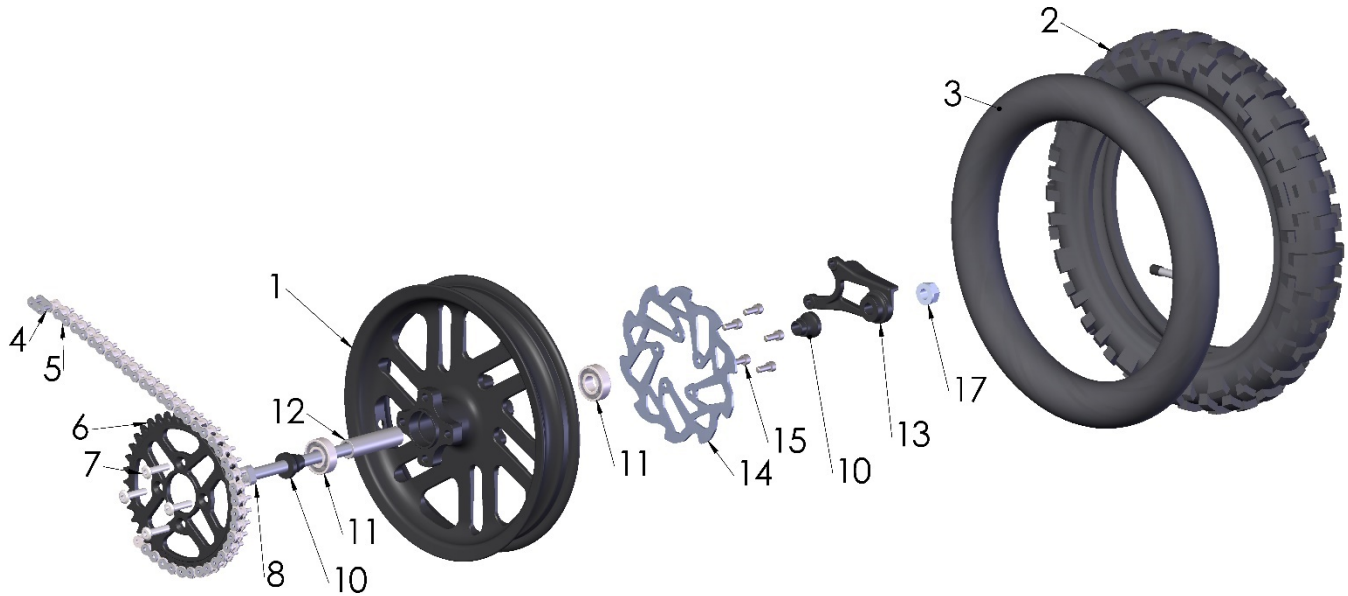

Rear Wheel		
REF #	PART #	DESCRIPTION
1	WAMUR021BLK	REAR WHEEL W/BEARINGS – BLACK
2	WCMU1075D34	TIRE - REAR - 70/100-10 - DUNLOP MX34
3	WCMUTU10	TUBE, 10"
4	PCMU0001	MASTER LINK 420
5	PCMU0102	CHAIN 420 X 102
6	PCC50250BLK	50T SPROCKET (STANDARD) 415 - BLACK
6A	PCC502xx	SPROCKET xx DENOTES TEETH – RANGE OF TEETH (34-45)
7	HCSP0701	M7X30mm SPECIAL HEAD BOLT (4 REQ'D)
7A	HCWF0701	7mm FLAT WASHER (4 REQ'D)
7B	HCNL0701	M7 LOCKNUT (4 REQ'D)
8	WCMU0016	AXLE BOLT 195mm
10	WCMU0101BLK	WHEEL SPACER (2 REQ'D)
11	WCMU0120	WHEEL BEARING (2 REQ'D)
12	WCMU0041	WHEEL BEARING SPACER
13	BCMU0045	CARRIER – BRAKE
14	BCMU0222	BRAKE ROTOR
15	HCBC0514	M5X14mm SOCKET HEAD CAP SCREWS (5 REQ'D)
17	HCNL1201	M12 LOCK NUT
ACCESSORY	HKMU0002	BOLT KIT – REAR SPROCKET

# Parts – Shock

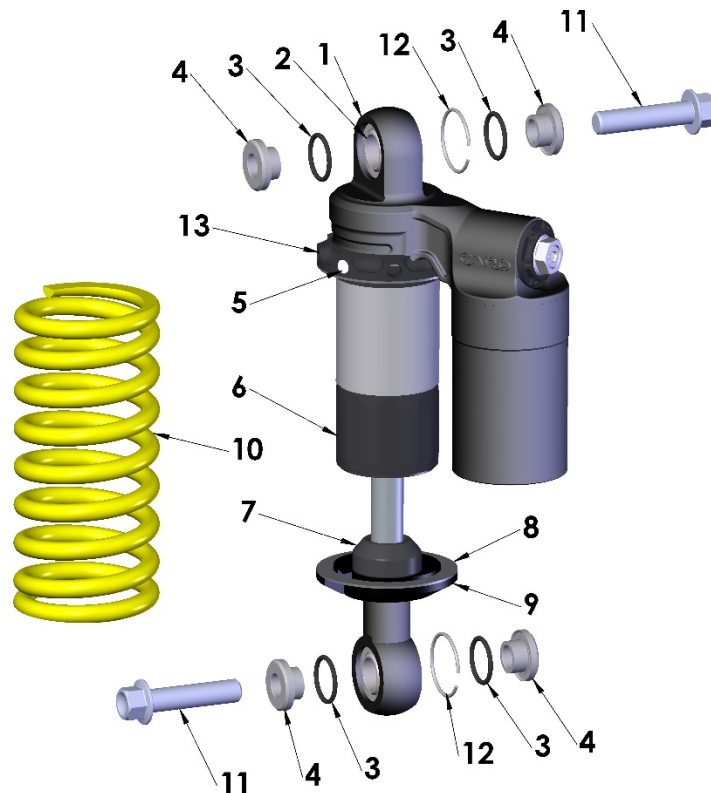

Shock		
REF #	PART #	DESCRIPTION
1	SACJ2025	SHOCK ABSORBER
2	SCMU0043	SHOCK – BEARING SPERICAL SHOCK MOUNT – (2REQ'D)
3	SCMU0039	O-RING – SHOCK – BUSHING (4 REQ'D)
4	SCMU0042	SHOCK – MOUNT BUSHING (4 REQ'D)
5	SCMU0058	SHOCK – WHITE NYLON TIP SET SCREW M6-1.0
6	SCMU0056	SHOCK – SLEEVE BLACK
7	SCCJ0004	BUMPER – JR - CARD SHOCK
8	SCMU0040	SHOCK – SPRING PAD
9	SCMU0054	SHOCK SPRING PERCH
10	SCMUOH05	SPRING – STANDARD (285 lb/in)
10	SCMUOH04	SPRING – LIGHT (275 lb/in)
10	SCMUOH06	SPRING – HEAVY (295 lb/in)
11	HCBF1039	M10X39 FLANGE HEAD BOLT
12	SCMU0330	RING -SPERICAL BEARING RETAINING -CARD SHOCKS
13	SCMU0120	PRELOAD ADJUSTER – CARD SHOCK
ACCESSORY	SKC60002	REBUILD KIT – CARD SHOCK

# Parts – Shock - Inside

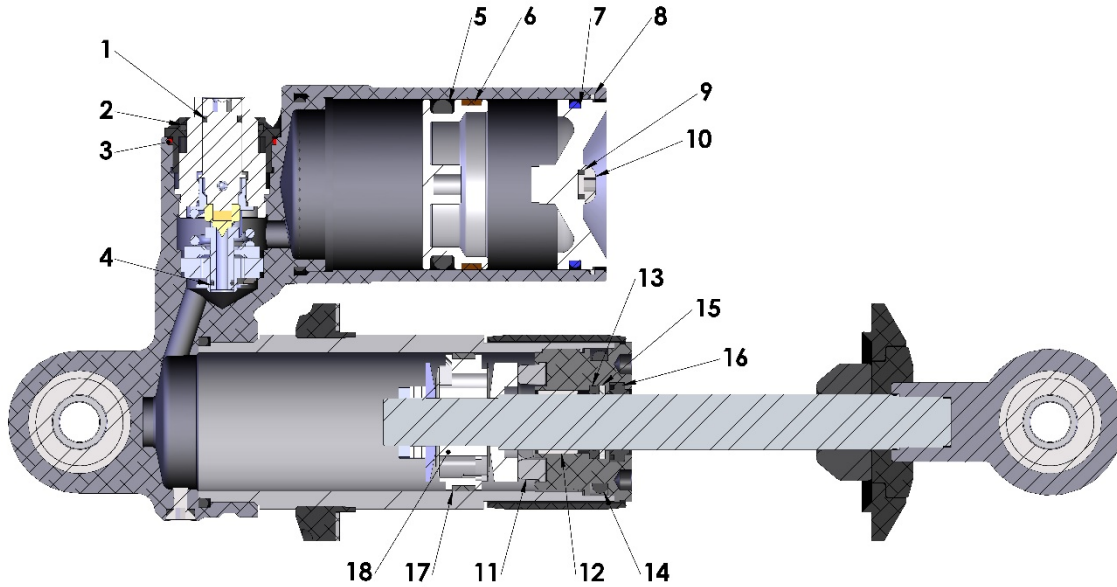

Shock		
REF #	PART #	DESCRIPTION
1	SCMU0037	O-RING LOW SPEED COMP ADJUSTER
2	SCMU0038	O-RING HIGH SPEED COMP ADJUSTER
3	SCMU0036	O-RING COMP ADJUSTER CAP
4	SCC60007	O-RING COMPRESSION ADJUSTER
5	SCMU0051	O-RING – IFP
6	SCMU0052	IFP SEAL BAND
7	SCMU0033	O-RING SHOCK BASE
8	SCMU0050	RESERVOIR CAP RETAINER RING
9	SCMU0035	O-RING CHARGE CAP
10	HCB0506	M5 X 6mm LONG BUTTON HEAD STAINLESS STEEL
11	SCMU0044	SEAL HEAD BUMPER
12	SCMU0048	SHAFT BUSHING
13	SCMU0046	X-RING SEAL
14	SCMU0034	O-RING SEAL HEAD
15	SCMU0047	SPACER - X-RING
16	SCMU0045	DUST SEAL
17	SCC60014	PISTON BAND
18	SCMU0091	PISTON - SHOCK
	SCCM0001	SEAL HEAD – WITHOUT COMPONENTS
	SKMU0002	SEAL HEAD - COMPLETE
ACCESSORY	SKC60002	REBUILD KIT – CARD SHOCK



# Parts – Swingarm Assembly

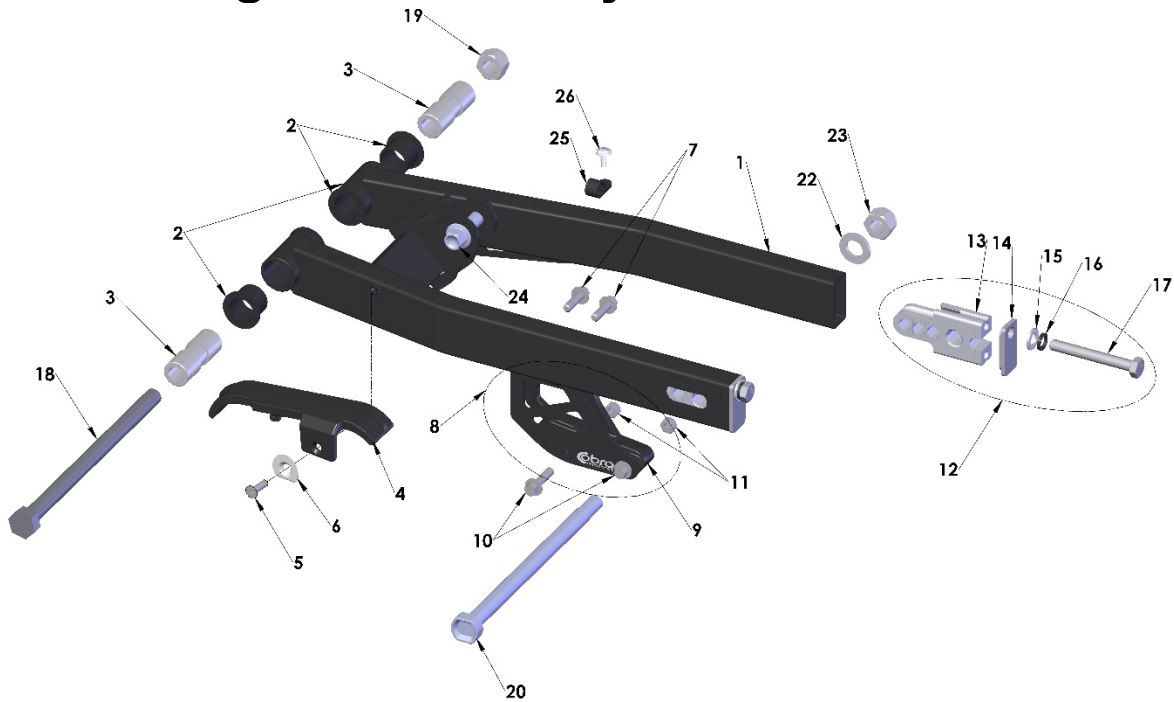

Swingarm		
REF #	PART #	DESCRIPTION
1	GAMU2025	SWINGARM – BLACK – 2025
2	GCMU0001	SWINGARM BUSHING (SINGLE PIECE) (4 REQ'D)
3	GCCS0001	SPACER - PIVOT TUBE (2REQ'D)
4	GCMU0041	SWINGARM CHAIN GUARD - CX50 - WITH MOHAWK AND FOOT
5	HCFH0512	M5X12mm FLAT HEAD SCREW
6	GCMU0038	RETAINING WASHER – SWING ARM GUARD
7	HCBF0620	M6X20mm FLANGE HEAD BOLT (2 REQ'D)
8	PAMU0001	CHAIN GUIDE – ASSEMBLY COMPLETE
9	PMU0060MP	CHAIN GUIDE - BOTTOM SLIDER & INSIDE
10	HCBF0625	M6X25mm FLANGE HEAD BOLT (2 REQ'D)
11	HCNL0601	M6 LOCKNUT (2 REQ'D)
12	FAMU0005	WHEEL PULL ASSEMBLY (BLOCK, CAP, BOLT, AND WASHER)
13	FCMU0203	WHEEL PULL
14	FCMU0202	WHEEL PULL ENDCAP
15	HCWF0802	8mm FLAT WASHER
16	HCWL0802	8mm LOCK WASHER
17	HCBH0810	M8X65mm HEX HEAD BOLT (FULL THREAD)
18	HCBH1203	SWINGARM PIVOT BOLT
19	HCNL1201	M12 LOCK NUT
20	WCMU0016	AXLE BOLT 195mm
22	HCNL1201	AXLE WASHER
23	HCNL1201	M12 LOCK NUT
24	HCBF1039	M10X40mm FLANGE HEAD BOLT
25	HCCC0006	CLAMP - BRAKE HOSE
26	HCPP0832	FASTENER – ½" SELF TAPPING

# Service

Trained technicians with precision gauging and proper assembly fixtures carefully assemble all Cobra engines to specific tolerances. If you feel you have the skills, and the appropriate tools, to perform the following service tasks please follow the instructions closely. The part numbers are listed throughout to help you when ordering parts from your local Cobra dealer.

If you don't feel comfortable with the service work, log on to [www.cobramoto.com](http://www.cobramoto.com) to find a Cobra dealer or Call 517-437-9100.

## **On board Diagnostics**

### ***4-0 Fault Recall function***

This is a new function of the firmware as of version 3.1.2(introduced as a 2024 feature).

To recall the last recorded fault:

1. Power up bike or Turn off bike propulsion with the "Go" button.
2. Then hold down the "Mode" button for 10sec. (till all blue lights come on and the go off)
3. Flash code will be in the format (X Number of Flashes) Short Pause (Y Number of Flashes)
4. This will form the code as X-Y
5. Then refer the fault code chart for fault description.

Next page

Details on each one in a table below this one.

<b>Blink Code</b>	<b>Description</b>	<b>E- Scope Code</b>
1-1	ETS_PWR - Throttle sensor power fault	All TBD
1-2	NVM - Non volatile memory fault	
2-1	ETSA - Throttle sensor A fault	
2-1	ETSB - Throttle sensor B fault	8704
2-1	ETS_REDUND_CHECK - Throttle sensor redundancy fault	
	ETKS_SNS - ETKS sensed value outside of expected range	
3-1	ETKS_UNST - ETKS key signal unstable	
3-2	ETKS_INV_STATE - Unrecognized ETKS key	
	MTR_SNS - Motor temperature sensor value outside of expected range	
4-1	MTR_HIGH_TMP - Motor temperature too hot for operation	
4-2	MTR_RPM - Motor RPM too high	
4-3	PHASE_OC - Motor phase over-voltage	
4-4	MDU_COMM MDU - Communication fault	
5-1	NET_COMM_TO - Communication timeout	128
5-1	MDU_TMP MDU - Temperature too hot for operation	
5-2	CTL_OT - Controller too hot	
5-2	HSNS_FAULT - Hall sensor fault	
5-4	CTL_UV - Controller under-voltage	
5-6	POST_SGT - Phase On Self Test Static Gating Test	
5-7	POST_DGT - Phase On Self Test Dynamic Gating Test	
5-8	H_STALL - Hall stall	
5-9	INST_CTL_OV - Instantaneous controller overvoltage	
6-2	INTERNAL MDU - internal fault	
6-3	CAN - CAN bus	
6-4	TORQ_SNS - Torque Sensor	
6-4	BOOTLOAD - Bootloader issue	
6-4	PARAM2_CRC - Calibration programming	
6-4	H_SNS_POS - Hall sensor position	
6-4	MTR_OT - Motor over-temperature	
7-1	BATT_DEV - Battery fault	
7-2	BATT_COMM - Battery communication fault	

# Motor Cooling Fluid Replacement

## Radiator fluid removal:

- 8mm hex key
  - Motor Cooling Fluid (MCMUMF32)
1. Remove radiator cap and drain engine cooling fluid using the 8mm hex key and the drain at the bottom of the motor.

**NOTE:** Inspect the old coolant for evidence of metal or other debris that may indicate a problem.

2. Inspect the o’ring and replace if necessary.
3. Reinstall the drain plug. Snug
4. Fill the system with 500 ml of Cobra Motor Cooling Fluid. ‘Burp’ the system of trapped air by rotating the motorcycle back in a ‘wheelie’ (while on the stand) until the system is free of trapped air.



## Rear wheel pullers

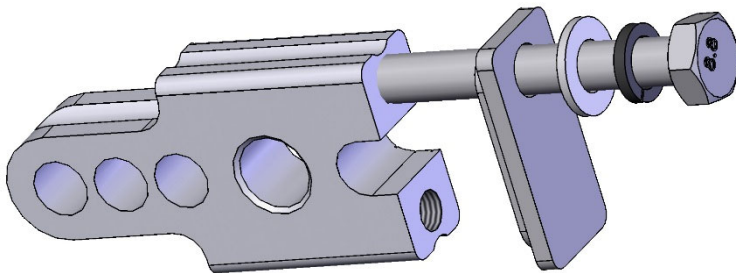

1. Remove axle, and back wheel assembly.
2. Pull the rear wheel pullers out of the back of the swing arm.

## Rear wheel alignment:

By eye, ensure that the rear sprocket is running true (in-line, planar) with the front sprocket. When the sprockets are running true, the wheel is properly straightened, and the chain will run straight.

# Brakes

Check before each ride:

- Make sure the brake does not have any leaks by holding the lever in while checking hose connections.
- Make sure the brake lever pressure is OK by pulling in on the lever and ensuring full braking performance is achieved before the lever touches the handlebar. If this is not the case, pump the lever several times until the lever feels firm.
- Always make sure the rotor and brake pads are free from oil and grease. Clean the rotor with mild dish soap or alcohol. Contaminated pads must be replaced.
- Ensure that the brake caliper is centered over the brake rotor. If a correction is needed, Cobra has thin brake shims to help make minor adjustments in alignment.
- Always leave adequate free-play in the lever or pedal.

**CAUTION:** This brake system uses only DOT 4 brake fluid!

# Front Forks

The front forks are fully serviceable, but it is recommended that only trained professionals should service them. Contact Cobra for questions and service of your forks.

# Rear Shock

The rear shock is fully serviceable but it is recommended that only trained professionals should service your shock. Contact Cobra for questions and service of your CX50 SR shock.

# Tuning

## Gearing

What happens with improper gearing?

- Poor performance
- Not enough top end speed
- No snap out of the corners
- No jump at the gate

Condition	Gear Taller	Gear Lower
Mud		↓ ↓
Sand		↓
Hills		↓
Hard Pack	↑	

Front Sprocket	Rear Sprocket	Gear Ratio		
	11	48	4.36	
	11	49	4.45	
	11	50	4.55	
	11	51	4.64	
	11	52	4.73	
10		48	4.80	
	11	53	4.82	
10		49	4.90	
	11	54	4.91	
10		50	5.00	<i>stock</i>
10		51	5.10	
10		52	5.20	
10		53	5.30	
10		54	5.40	

# Front Fork Operation

The front suspension on the CX50SR works under the principals of hydraulic damping

## Rear Shock Adjustments

Always start with standard settings and make damping changes in no more than two click increments and only make one change at a time.

Symptom	Action
Rear end feels stiff on small bumps	Softer Low Speed Compression Damping
Rear end 'sways' on straights	Harder Low Speed Compression Damping
Bike tends to jump 'rear end high'	Harder High Speed Compression
Bike tends to jump 'rear end low'	Softer High Speed Compression
Frequent rear end bottoming	Harder Compression Damping
Bottoms after end of continuous bumps	Softer rebound damping
Rear end 'kicks' over square edge bumps	1) Harder rebound, 2) Softer Low and High Speed Compression
Rear end feels stiff under acceleration bumps.	Softer Rebound and/or Stiffer Low Speed Compression Damping

## Proactive Suspension Adjustments

Once you have the suspension adjusted for decent overall feel, you can make proactive adjustments when faced with different racing conditions.

Situation	Actions
Sand track	Lower the rear end (increase race sag).
Sand track	Stiffer compression and rebound damping.
Long fast track	Lower the forks in the clamps by 3 mm.
Tight slow track	Raise the forks in the clamps by 3 mm.
Mud track	Lower the bike if the rider has difficulties touching the ground.

## Shock preload

Loosen the set screw and turn the spring perch in full turn increments to get the desired sag settings.

### NOTE:

Always leave the spring perch rotated in such position so that the set screw is easily accessible.

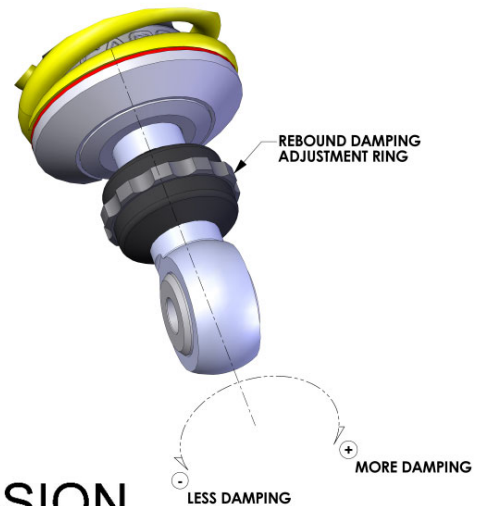

## Shock Damping

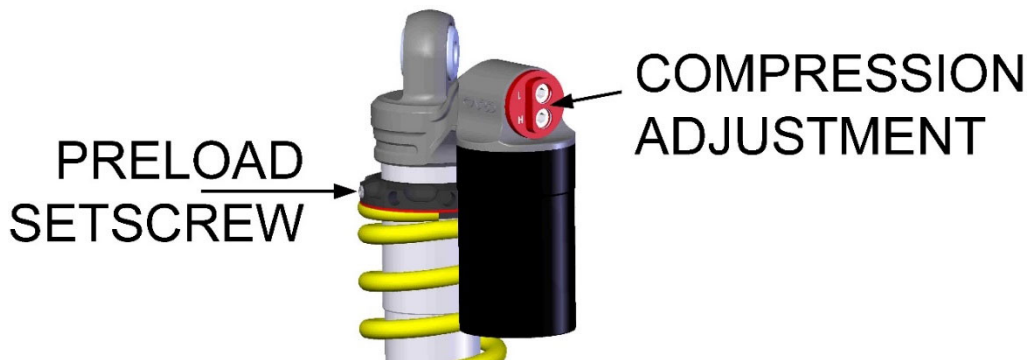

The Low Speed “L” adjustment is what controls how quickly the rear of the bike settles in the corners or how it settles in sweeping ‘flat track’ style corners whereas the High Speed “H” adjustment controls how the shock reacts to kickers. In “+” adds damping or slows it down, whereas out, “-“ speeds up the shock or removes damping.



# Troubleshooting

- **RDU Lower Left Fault light: Battery Fault**
- **RDU Lower Right Fault Light: Electrical System**
- **Bike doesn't run at all, RDU Lower Red Fault light is On solid.**
  - Order of replacement(2023):
    1. Replace Hall Board in motor
    2. Controller
    3. RDU

For 2024 bikes, please refer to the Flash Code Diagnostics

- **Bike runs for 5-10mins stops with RDU lower right Red Fault light...**
  - Change Hall Board
- **Bike is slow and coolant smells burnt?**
  - Replace motor and coolant
- **Bike doesn't run at all, RDU Lower right Red Fault light flashes with turning rear wheel.**
  - Change hall sensor board
- **If bike has just been washed with or without battery:**
  - Allow ample time to dry before powering back up.
- **Motor has extra high drag, runs rough or seal leaking:**
  - Possible bearing issue, replace motor
- **Run time is short, coolant doesn't smell burnt:**
  - Replace battery pack
- **Bike doesn't have the power it did:**
  - Check for binding / oil the chain (other maintenance)
  - Ensure it has latest software
  - Does bike have 150+ cycles on battery? If yes, may be time for replacement/refresh.
  - Check for loose high power connections.
  - Change RDU and test.

**Change Control**

<b>Who</b>	<b>Rev</b>	<b>Date Pub</b>	<b>Assy/pg</b>	<b>Changes made</b>
SH	Pre release			Updated Mode Definitions, 3e Features
PDM	Release	11/12/24		