

FX SE



CHAMPIONS START HERE.™

Owners
Parts
Service
Tuning

For **parts orders**, contact your local dealer.

To locate your closest Cobra dealer, log on to

www.cobramoto.com

or call

+1 (517) 437 - 9100



Cobra MOTO, LLC
240 Uran Road
Hillsdale, MI 49242
USA

DISCLAIMER OF WARRANTY

This motorcycle is sold "as is" with all faults, obvious or not. There are no warranties expressed or implied, including any warranty of merchantability and warranty of fitness for any particular purpose.

Motorcycles are generally not covered by homeowner or trailer content insurance, and they typically require their own policy. Contact your own insurance company for specific details.

"WARNING"

THE COBRA CX5E IS A COMPETITION MODEL ONLY AND IS NOT MANUFACTURED FOR, NOR SHOULD IT BE USED ON PUBLIC STREETS, ROADS, OR HIGHWAYS.

THE USE OF THIS BIKE SHOULD BE LIMITED TO PARTICIPATION IN SANCTIONED COMPETITION EVENTS UPON A CLOSED COURSE BY A SUFFICIENTLY SKILLED RIDER AND SHOULD NOT BE USED FOR GENERAL OFF-ROAD RECREATIONAL RIDING.

IMPROPER USE OF THIS MOTORCYCLE CAN CAUSE INJURY OR DEATH.

THIS BIKE IS INTENDED FOR EXPERIENCED RACERS ONLY AND NOT FOR BEGINNERS.

IT IS YOUR RESPONSIBILITY AS THE OWNER OF THIS COBRA MOTORCYCLE OR AS THE PARENT, OR LEGAL GUARDIAN OF THE OPERATOR, TO KEEP THIS COBRA MOTORCYCLE IN PROPER OPERATING CONDITION.

THIS BIKE WAS DESIGNED FOR RIDERS THAT WEIGH LESS THAN 80 LBS WITH FULL RIDING GEAR AND SHOULD NOT BE OPERATED BY RIDERS THAT WEIGH MORE THAN THAT.

BE SURE THAT THE RIDER ALWAYS WEARS ADEQUATE SAFETY GEAR EVERYTIME HE OR SHE RIDES THEIR COBRA MOTORCYCLE.

"WARNING"

This product contains Lithium-Ion battery cells which are very good at storing a lot of energy for a fast fun motorcycle but are potentially very dangerous. For your family's safety, follow the instructions on the next page

IMPORTANT SAFETY NOTICE

⚠ WARNING

Failure to follow WARNING instructions could result in severe injury or death to the machine operator, a bystander, or a person inspecting or repairing the machine.

CAUTION:

A CAUTION indicates special precautions that must be taken to avoid damage to the machine.

NOTE: A NOTE provides key information to make procedures easier or clearer.

Lithium-Ion Battery Safety

When not preparing for a race, store the battery with partial charge (2 lights lit, not 3, only the red “S” light and orange “V” lights lit), and away from heat sources.

Store and charge your Cobra CX-E in a place where a fire would cause the least harm.

Additional best practice guidelines below:

- Tampering with the battery, charger, and/or electronics of the motorcycle would be jeopardizing safety.
- Do NOT use Electrolytic Grease or other contaminants on the battery power connector terminals.
- Fully charge the battery **only just prior** to using it.
- Battery / bike Storage (2 lights of charge as stated above)
 - Not in direct sunlight, temperature between 32°F – 110°F (cooler better)
 - Keep away from other heat sources that allow the surface to be ‘hot’ to the touch (115°F)
- Transportation of batteries to protect against shock or impact (2 lights of charge):
 - Batteries are best transported in the motorcycle, covered with a Lithium – Ion fire suppression blanket and protected from contact with other items.
<https://brimstonefireprotection.com/>
 - Batteries not in the motorcycle should be kept in a container (2 lights of charge):
 - Lithium-Ion safe battery case for 1 kWh capacity (in case of energy release). <https://www.denios-us.com/lithium-ion-transport-box-M2921000/M292100>
 - Or minimally an impact absorbing case to avoid sliding, dropping, or impacts during transport. (This will not contain spontaneous energy release but will protect it from unintended impacts. [Available soon from Cobra.](#))
- Clean the battery pack by hand – NOT WITH PRESSURE WASHER.
- When cleaning the battery outside of the bike (recommended) install connector sealing covers to avoid contamination of the terminals.
- A battery that has been dropped or has crash damage should be isolated to a safe location (assume it could ignite at any time). Keep isolated and call Cobra tech ASAP 517 437 9100.
 - Signs of internal heat, escaping smoke, or hissing noise – get away fast, otherwise,
 - Does the housing appear compromised (dent, crack, etc..)?
 - Will the battery pack power up?
 - What is the state of charge?

Table of Contents

LITHIUM-ION BATTERY SAFETY	2
GENERAL INFORMATION	5
SPECIFICATIONS - GENERAL.....	5
OPTIONAL SUSPENSION COMPONENTS.....	6
SPECIFICATIONS - TORQUE VALUES.....	7
POWER UP PROCEDURE	8
DO'S AND DON'T'S.....	9
MAINTENANCE	11
TIPS	11
SCHEDULE	12
REPLACING MOTOR COOLING FLUID.....	12
PROPER CHAIN ADJUSTMENT	13
REAR BRAKE PEDAL HEIGHT.....	14
FORK MAINTENANCE.....	15
<i>Fork Air Bleeding</i>	15
<i>Fork Oil Replacement</i>	15
DISASSEMBLY PROCEDURE	16
PARTS – BARS AND CONTROLS	17
PARTS – BATTERY	18
PARTS – COOLANT SYSTEM.....	19
PARTS – ELECTRICAL SYSTEM.....	20
PARTS – ELECTRONICS BOX.....	21
PARTS – FORKS & TRIPLE CLAMPS	22
PARTS – FORKS – LEG ASSEMBLY – BRAKE SIDE	24
PARTS - FORKS – LEG ASSEMBLY – NON-BRAKE SIDE.....	26
PARTS – FRAME & SUBFRAME	28
PARTS – FRONT BRAKES.....	29
PARTS – FRONT WHEEL	30
PARTS – MOTOR SYSTEM - INTERNALS.....	31

PARTS – PLASTIC BODYWORK & SEAT	34
PARTS – REAR BRAKE	36
PARTS – REAR WHEEL	38
PARTS – SHOCK	39
PARTS – SHOCK - INSIDE	40
PARTS – SWINGARM ASSEMBLY	41
SERVICE	42
ON BOARD DIAGNOSTICS	42
MOTOR COOLING FLUID REPLACEMENT	44
REAR WHEEL PULLERS	44
BRAKES	45
FRONT FORKS	45
REAR SHOCK	45
TUNING	46
GEARING	46
<i>Front Fork Operation</i>	47
<i>Fork Damping Adjustments</i>	47
<i>Rear Shock Adjustments</i>	48
TROUBLESHOOTING	50

General Information

Specifications - General

Items	CX50 FWE
Dimensions Wheelbase Wheel size Seat height	41" (1041mm) 10" (254mm) rear, 12" (305mm) front 26" (660mm)
Motor Type Cooling system Coolant Final drive ratio Chain	Cobra – out runner Liquid-cooled Cobra Motor Cooling Fluid, 500 ml 10/49 T 110 links 420
Chassis Front tire Pressure Rear tire Pressure Front fork Fork oil type Fork oil amount Std settings (turns) Rear shock (std. settings)	2.50 (60/100) - 12" 16 psi minimum 2.75 (80/100) - 10" 16 psi min. (20 psi for hard pack or rocky conditions) CARD 32mm USD Fully Adjustable w/ Smart Leg 5wt Fork Oil 150 ml Smart leg: 1.5 out, Compression and rebound 2 out Compression: Low 12 clicks out, High 15 clicks out Rebound 16 clicks out, Race/Free sag 75/25mm

Optional Suspension Components

Weight of Rider (lb)	Fork Spring	Shock Spring
Less than 50 lb	0.23 kg/mm KCCS3223	green, 2.9 kg/mm SCKGFX29
50-60	0.25 kg/mm KCCS3225	black, 3.1 kg/mm SCKGFX31
60-75	0.25 kg/mm KCCS3225	red, 3.3 kg/mm SCKGFX33
Greater than 80	0.27 kg/mm KCCS3227	gray, 3.5 kg/mm SCKGFX35

Specifications - Torque Values

Fastener	Torque Value			Loctite™	Size & Remarks
	ft-lb	in-lb	Nm		
Phase & power to MDU	4.4	53	6.0	No	M5 x 0.8
Phase wires to Motor	3.0	35	4.0	no	M6x1.0, copper
Motor mount bolts	22	265	30		M8 X 1.25
Swingarm pivot	21	250	28		M14 X 2.0
Shock bolt	35	420	47	243	M10 x 1.5
Rear axle nuts	21	250	28		M12 X 1.25
Rear sprocket bolts	21	250	28		M7 X 1.0
Front axle aluminum bolt	9-11	106-132	12-15	243	M10 X 1.25
Fork guard alum bolts	6	88	8	243	M6X1, ALUM
Front axle pinch bolts	7.5	88	10		M6 x 1.0
Brake caliper bolts	9	106	12	243	M6 x 1.0
Brake caliper to carrier	7	84	9.5	243	M6 x 1.0
Brake pad secure	3	36	4		M5 x 0.8
Banjo bolts – brakes	15	177	20		M8 x 1.25
Brake rotor bolts	9	108	12	243	M5 x 0.8
Triple clamp bolt (top)	8	90	10		M8 x 1.25
Steering stem pinch bolt	9.5	115	13		M8 x 1.25
Triple clamp bolts (bottom)	6	72	8		M6 x 1.0

Power Up Procedure

- Before Powering Up the machine inspect the following
 - Tire pressure
 - Chain tension
 - Cooling fluid level
 - Proper wear on chain rollers and sliders
 - Handlebar tightness
 - Throttle assembly movement
 - Check for loose nuts and bolts
- Turn the battery on by pressing the **Power Button** for 1-2 seconds

WARNING

Always wear a helmet and other protective riding gear.

CAUTION: Make sure your rider's foot is not resting on the foot brake while they are riding.

For charging...

Ensure good AC power....if not, fast charging may produce faults.... however, slow charge is still an option on slightly bad power.

Charging Procedure:

Plug Charger into AC, then Plug into battery with Positive wire towards the back of the bike...while turning the lock ring clockwise to lock it down. Ensure that the connector goes together evenly. Then press the battery power button once and wait a few seconds. The voltage indicator on the battery will start flashing slowly (slow charge). Then hit the battery power button one more time and the voltage indicator will now start flashing faster.

Slow Charge: 3.5-4 hours, Fast Charge: 1-1.25 hour. Once all the lights on the battery charge indicator are solid and not flashing charging is complete. Low power chargers will only slow charge. High power chargers have both charge modes.

There is a new "**Pre-Race**" charge mode... once battery is already full. Turn battery off with long press on the battery power button....then back on. When the battery sees that it is already charged it will run the "Pre-Race" algorithm... and prepares the pack for maximum runtime.

Do's and Don't's

Don't:

1. Don't store the battery fully charged.

WARNING

Energy stored in Lithium-Ion battery packs have the potential to accidentally / unintentionally release their energy rapidly if an internal cell becomes compromised. Less energy to release is better.

2. Don't leave battery with 1 light on charge indicator for extended time.

CAUTION:

A battery stored with only 1 light of charge may run out of energy while resting on the shelf and it's not possible to recharge a battery after it discharges beyond a certain point.

3. Don't wash improperly. See washing best methods.
4. Don't fill with anti-freeze.

CAUTION:

Motor Coolant is not engine Anti-Freeze!...it is petroleum based with special additives. Anti-Freeze is conductive and will damage the bike.

5. Don't totally fill the cooling system. There is coolant in the system even though you can't see it when taking the cap off. With the bike on the stand and powered up, apply some throttle and you should see fluid flowing in the radiator... that is all you need to see!
6. Don't put grease on the power contacts of the batter power connector. Grease is not a good electrical conductor. It works fine on 12V low current trailer light connection to keep water out and avoid corrosion, but acts like a current drawing resistor when applied to the bikes battery.
7. Don't over tighten rear axle as this could add drag to the motor.
8. Don't plug or unplug the battery from the bike or charger with it turned on!

Do:

1. Do power the battery to 2 lights on battery indicator before storing. Bike can be plugged into battery when stored.
2. Do check chain sliders and sprockets for wear regularly.
3. Do change cooling fluid every 3 months.
4. Do lube chain between each moto.
5. Do run off the battery before plugging in or unplugging from the charger or bike!

Additional info for those serious racers:

1. Warm up motor before racing for better starts. Feel radiator with hand until close to normal running temp is reached.
2. Top off battery after warm up cycle. This is a balance as motor temp is cooling while charging.
3. Adding a couple psi to rear tire would improve top speed and runtime, but at the cost of a little initial traction.

4. If run time is a priority, please see “Pre-Race” charge mode.

Change Bike Modes:

Bike must be disabled (“Active” light is off), before mode can be changed. Hitting the “GO” button activates and deactivates the bike.

Add the LED light numbers to get the mode number. So if 1 and 3 are lit, then that is mode 4. Hitting the upper Left Mode button cycles through modes.

Modes:

1. Mode 1 is ~12mins of full power with a quicker de-power at the last stage before going into turtle mode....make sure they are aware. Once in turtle mode, lite throttle to get back to pits, too much and it will stop the bike. This is our normal race mode.
2. Mode 2 is 14-15mins of a gradual power reduction to increase run time....this is similar to how competing bikes acts over a full battery run. Same peak power as mode 1.
3. Mode 3 is a lower power version of Mode 1(approx. 95%), Mode 4 is a lower power version of Mode 2(95%)
4. Other modes are in flux, but there are slick track version of mode 1 on Mode 5, it just has a softer feel. Mode 6 is a development mode, same as Mode1 as of 5/16/2024....this can change based on feedback.

Holeshot Mode:

1. 2024 60v bikes currently do not have the holeshot mode active, we plan to add this with future update. Starting performance is higher than the 2023 bike as is.
2. It will be automatically armed when the bike is "Active"... Once the throttle hits 100%, Holeshot mode will engage for 8secs. If a false start happens and race restarted, then get back to the gate and hit the "GO" button to deactivate, then reactivate with the "Go" button again. This resets/rearms the Holeshot mode.
3. Small throttle blips will keep the bike from going to sleep as there is a 1 minute inactivity timeout.

Washing:

1. Please pull the battery out of the bike to wash(it's just three 11mm nuts).... that would eliminate 75-95% or more of the electrical problems ebikes tend to have either way.
2. Check for dirt/mud in main bike connector and clear with Q-tip or paper towel. There is also a Bike side block off plug Item# DCCEMU002 to keep the bike side connector free of water and dirt.
3. Wash RDU and Tank area sparingly, avoid direct pressure spray.
4. Allow ample drying time, do not store in enclosed area while wet.
5. Be mindful of anything with wires coming out of it. Things can be waterproof, but those same things may not be pressure washing proof.

Other:

1. While on track, if active light starts flashing....either from falling over and being tilting too long or kill switch key falling off... when issue is resolved, one button press of the "GO" button will reset and allow rider to continue on.

2. If lower red fault light(Lightning bolt) comes on while riding and bike will not run... most likely a hall sensor board issue and should be first item to be replaced. Otherwise, check wiring for pinches, etc. This fault light is also a "catch all" for other bike system issues...kill switch, non-zero throttle, loss of CAN bus etc.
3. Lower left fault light(Battery) indicates an issue with the battery and needs to be looked at. Check battery indicators for fault code. IE. "M" light is red and another Letter is lit red as well.
4. After sitting a few weeks or from brand new... batteries will need a few runs to "Wake" up. Performance will improve over that time. Approx 4 or 5 cycles.
5. We should also have other optional sprockets available soon.... a 2 tooth change is significant. We will have 48, 49, 50 and 51T available soon. 49 or 50T is standard. Check with your dealer.

Other issues:

1. While we feel we have taken care of the 99.5% of the issues we are aware of, there is still the possibility of other small bugs or a parts failure(Electronics, batteries or wiring) that could be possible. We will do our best to find any new issues and fix ASAP.
2. Doing troubleshooting remotely is no fun for anyone. We have options to get a diagnostic tool in people's hands as quickly as possible. A dealer diagnostic tool is also available.
3. Battery change can happen in under 1 min. No serial number or programming change needed. Potential for 1 practice pack to ride bike to the line(warmup), then swap battery in staging for race pack...so full pack and warm motor....lots of possibilities around that.

Maintenance

A properly maintained machine is safer, faster, and more fun to ride. It is important that you adhere to this maintenance schedule to promote the longevity of your Cobra Motorcycle.

Tips

1. Cobra Motor Cooling Fluid is the ONLY cooling fluid that is compatible with high voltage electronics and provides the necessary lubrication for the bearings.

CAUTION: Coolant designed for Internal Combustion Engines (motor coolant, engine coolant, antifreeze, etc....) is not compatible with the high voltage electronics in the motor and will cause motor faults, potential damage, and an avoidable tech call and down time.

2. New chains will stretch on first use. Never install a new chain prior to a race. Always 'break' them in during practice.
3. Your Cobra Motorcycle has a 10-digit VIN (Vehicle Identification Number). The first three digits indicate the model while the sixth and seventh indicates the model year.
 - a. Example, FWExx17xxx is a 2017 CX50 SR.
4. The frame is 4130 Chrome Moly & HSLA, and it is important to weld it with the proper rod and heat settings set as light as possible. Cobra recommends replacing the frame with a new one if the old one becomes damaged. Use ER70S6 filler if welding on the frame.

Schedule

- Prior to each ride
 - Chain for proper tension and lubrication
 - Chain 'slider' wear on both chain sliders
 - Insure the smooth operation of the electronic throttle cable.
 - Check for adequate tire pressures and adjust if necessary.
 - Check all nuts and bolts for proper torque and re-torque if necessary.
 - Check the frame for cracks in the metal or cracks in the paint that might indicate that the metal has been stressed beyond its safe limits. Replace or get properly re-welded as necessary.
 - Check the rims for signs of stress; like cracks around the rim, spokes, and hub.
 - Equalize the pressure in the forks with atmosphere. Release any pressure built up inside the fork by loosening the bleed screw on the fork cap. Retightening after pressure is released.
- Every 20 hours of operation
 - Replace the fork oil.
 - Have the shock oil replaced by a Certified Cobra Mechanic.
- Every 50 hours of operation
 - Replace the Motor Cooling Fluid.

Replacing Motor Cooling Fluid

Tools needed:

- 8mm Allen wrench
- Minimum of 500 cc (16 oz) *Cobra Motor Cooling Fluid* (Part #MCMUMF32).

Procedure:

(to be completed)

Youtube videos available: search "CX5e Coolant"

Proper Chain adjustment

Tools required for chain adjustment

- 19 mm wrench or socket
- 13 mm wrench or socket

1. Make sure that the rear wheel is aligned properly.
2. For proper adjustment, the chain should have 35mm (1.378") free movement just behind the chain guard with no load on the bike (figure 2)

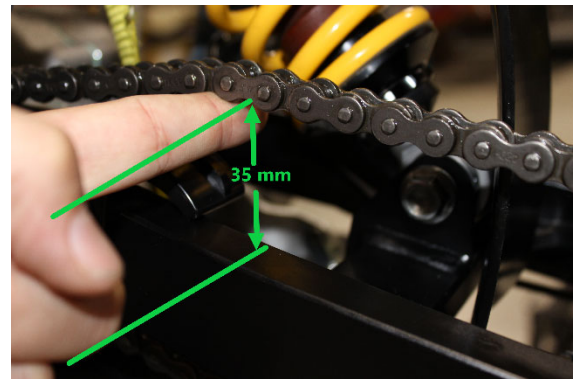
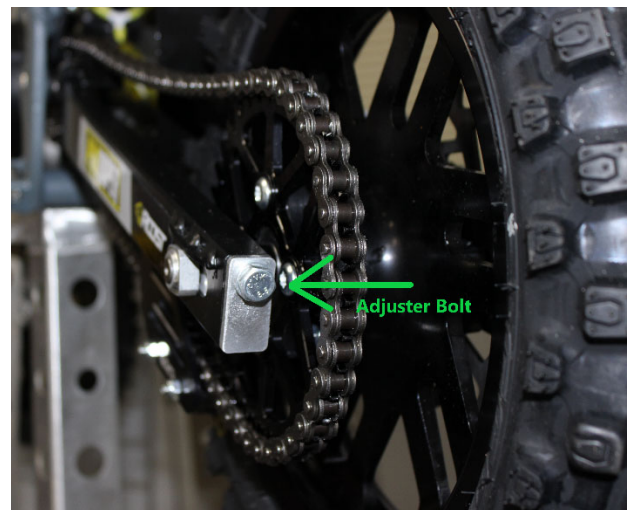

Figure 2

CAUTION:

Sit on the bike and verify that the chain has a minimum of 12mm (1/2") free movement when the chain is at its tightest point.

3. If the chain requires adjusting, loosen the axle with a 19 mm wrench and tighten the chain by rotating the adjuster bolts clockwise (CW) or loosen the chain by rotating the adjuster bolts (CCW).
4. Ensure proper alignment of the rear wheel by making sure there are equal amounts of the alignment holes (figure 4) showing on each side of the wheel.
5. Retighten the axel bolt to 25 ft-lb (34 Nm).



6. Retighten the adjuster bolt (figure 3)

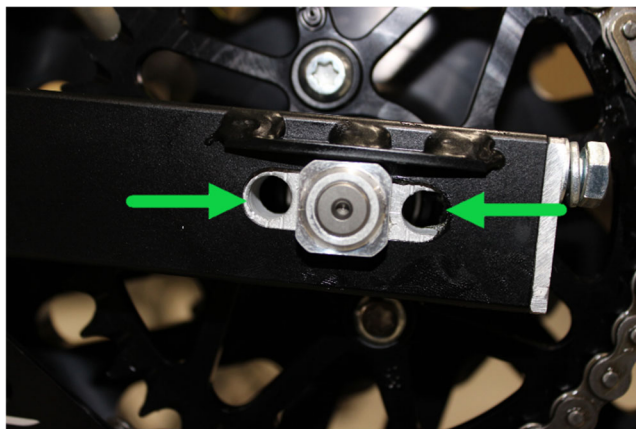

Figure 3 (top), Figure 4 (bottom)

Rear Brake Pedal Height

Brake pedal toe tip height can be adjusted with the nut and adjuster located below the rear brake master cylinder. The free-play is not adjustable on this model.

CAUTION: Use a New container of VP Racing: 622 DOT4 Racing Brake Fluid if necessary to add fluid.

Setting rear brake pedal position (see figure 2b):

1. Loosen the height adjust lock nut (10mm wrench)
2. Adjust the height adjustment shaft (fingers on the threaded portion of the plunger) to raise or lower the pedal:
 - a. Standing riding position, and
 - b. Sitting riding position.
3. Tighten the height adjust lock nut.

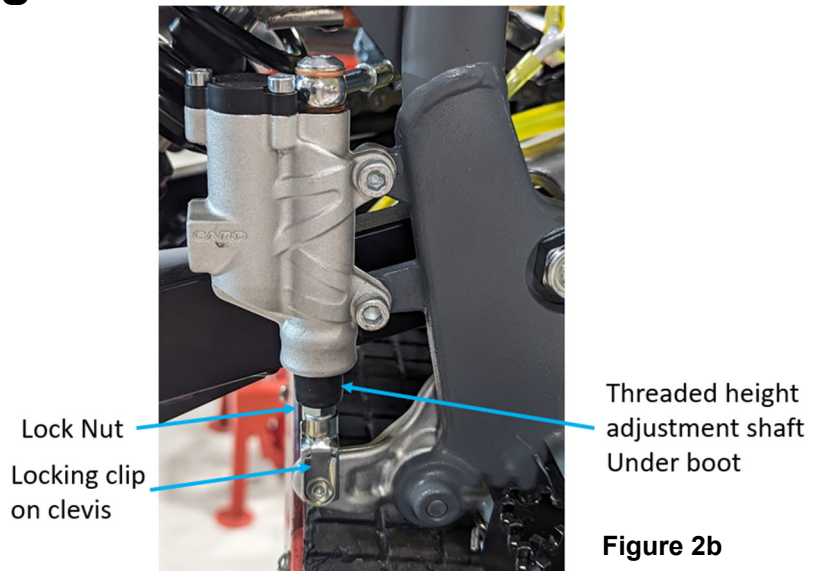

Figure 2b

NOTE: If it's not possible to rotate the threaded adjuster by finger, the next way would be to remove the clevis from the brake pedal by popping of the **Locking Clip**, use vice grips or similar on the threaded portion to keep it from rotating, and use a wrench on the square portion of the clevis that remains on the brake plunger

NOTE: Turning the clevis Clockwise will lengthen the adjuster (plunger), will raise the toe tip of the brake pedal, and turning the clevis Counter-Clockwise will shorten the adjuster (plunger) lowering the toe tip of the brake pedal.

⚠ WARNING

Make sure that the free play locking clip is installed such that one must push forward, toward the front of the bike, to remove. Otherwise the clip is apt to come undone while riding.

Fork Maintenance

Cobra strongly recommends that a professional service technician conduct all internal maintenance other than changing springs and oil. This will help to ensure safe and consistent operation.

For routine maintenance, the chart below provides suggested service intervals for common procedures:

	<u><i>Each Ride</i></u>	<u><i>10 hours</i></u>	<u><i>20 hours</i></u>	<u><i>As Needed</i></u>
<u><i>Bleed excess air</i></u>	<u><i>X</i></u>			
<u><i>Change Oil</i></u>		<u><i>X</i></u>		
<u><i>Change Seal/Striper</i></u>			<u><i>X</i></u>	
<u><i>Change Bushings</i></u>				<u><i>X</i></u>

Fork Air Bleeding

Tools required

- 3mm hex key (Allen wrench)

During normal operation, both fork legs will build up air pressure. This pressure acts as an additional spring so it must be bled on a regular basis to maintain consistent suspension operation. Before each ride, loosen the socket head cap screw located at the front of each fork cap far enough so that any excess pressure in the leg is relieved. After excess air is bled off, retighten the screw to 5 in-lb. Be careful not to lose or damage the sealing ring that is located under the head of each bleed screw.

Fork Oil Replacement

Tools required

- 32mm Fork Cap Tool (MCMUTL32)
- 8mm Allen wrench
- 4 & 5 mm hex key (Allen wrench)
- 9/16 wrench
- Mallet
- 5 wt. VP fork oil

Disassembly procedure

1. Remove the front wheel and axle (8mm Allen wrench).
2. Remove brake line clamp.
3. Remove the brake caliper from the fork leg (4mm hex key).
4. Loosen the top pinch bolts (6mm hex key).
5. Loosen the fork caps (32mm fork cap tool).
6. Loosen the bottom pinch bolts (5mm hex key).
7. Remove the fork legs from the triple clamps (5 and 8mm hex key).
8. One leg at a time
 - a. Remove the fork cap from the fork tube.
 - b. Pull the fork spring down to gain access to the fork cap jam nut and secure it with a 9/16 wrench.
 - c. Holding in one hand the 9/16 wrench use the fork cap wrench to unscrew the fork cap from the damper rod.
 - d. Remove the fork spring pad, and fork spring.
 - e. Inside the damper rod, the rebound adjustment screw pin is resting and will fall out of the damper rod when the fork is inverted. Try to catch it before it falls into your oil bucket.
 - f. Invert the fork and allow the oil to drain completely. Working the damper rod up and down will speed up the draining process.

Assembly procedure

1. Fill the fork with 150ml of fork oil.
2. Work the damper rod up and down to allow the fork cartridge to fill with oil.
3. Install the rebound adjustment screw pin into the damper rod.
4. Install the fork spring and spring pad.
5. Extend the damper rod completely and Compress the fork spring enough to begin threading the fork cap back onto the damper rod.
6. Make sure that the fork cap threads onto the damper rod completely before it makes contact with the jamnut.
7. Tighten the jamnut.
8. Tighten the fork cap to the fork leg outer
9. Install each leg back into the triple clamp. Torque each pinch bolt to 14N-m (10.3 ft-lb) making sure both legs are set to the same height in the clamps.
10. Pump the fork leg several times to verify that it operates smoothly.
11. Reinstall the brake caliper.
12. Reinstall the front wheel (25 ft-lb, 34 Nm).

Parts – Bars and Controls

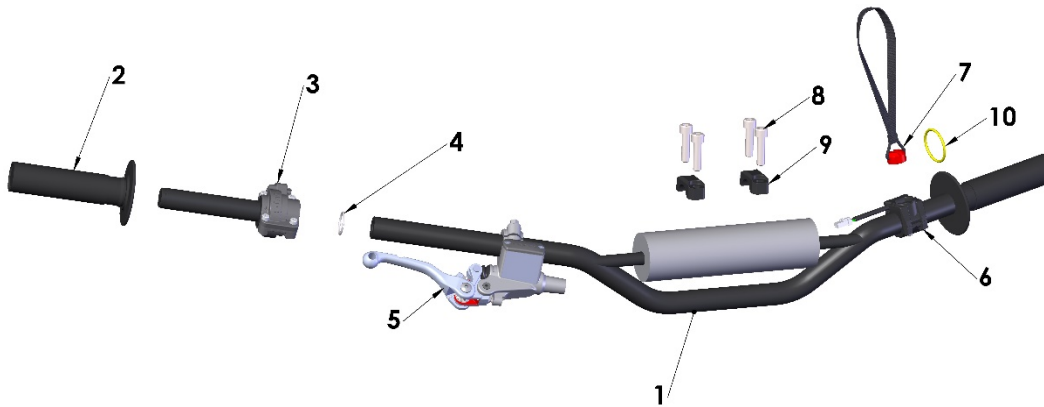

Bars and Controls		
REF #	PART #	DESCRIPTION
1	FAMU0017	HANDLEBAS – MICROBARS – COBRA BEND
2	TCMU0021	GRIPS (SET OF TWO) – MICROGRIPS
3	JACE50006MP	THROTTLE ASSEMBLY – TWIG - ELECTRONIC
3A	HCBC0412	M4x12 SHSC
4	FCMU0041	STOP RING – MICRO BAR THROTTLE
5		SEE FRONT BRAKE
6	NCCEMU001MP	KILL SWITCH ASSEMBLY - MAGNETIC
7	NCCEMU002	KEY – RED – RACER - KILL SWITCH ACTIVATE
7	NCCEMU005	KEY – YELLOW – RACER - KILL SWITCH ACTIVATE
8	HCBC0830	M8X30mm SOCKET HEAD CAP SCREW (4 REQ'D)
9	TCMU0060BLK	BAR CLAMP – BLACK (2 REQ'D)
10	ZCMUOR08	O-RING – KEY RETAINER
ACCESSORY	MCMUAM11	GRIP DONUT – PAIR – PRO TAPER MICRO BAR
ACCESSORY	FKMU0004	HANDLEBAR KIT- PRO TAPER MICRO- WITH COBRA THROTTLE AND GRIPS
ACCESSORY	TKMU00002BLK	BAR RISER KIT

Parts – Battery

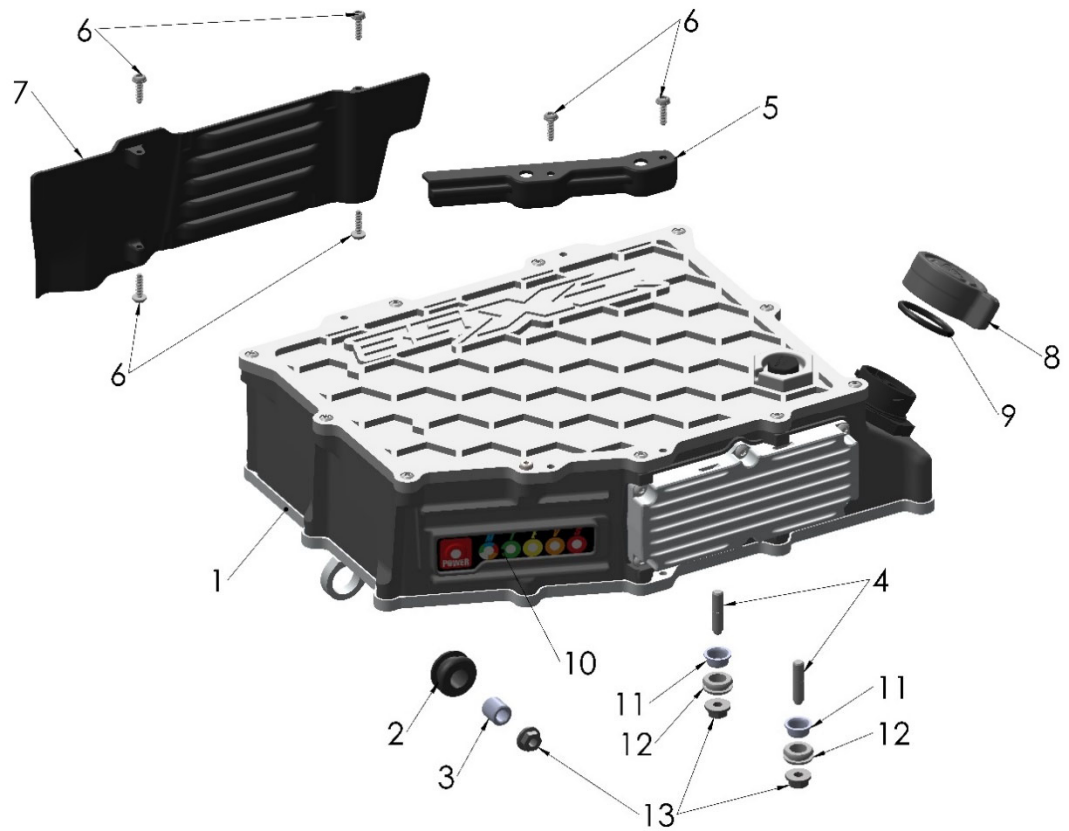

Battery		
REF #	PART #	DESCRIPTION
1	DACE10060MP	BATTERY ASSY – 1.0 kWh – 60V - MOUNTING HARDWARE
2	DCCE10010	GROMMET – REAR BATTERY MOUNT 1kWh
3	DCCE10009	COMP LIMITER – REAR BATTERY MOUNT 1kWh
4	DCCE10006	STUD – FRONT BATTERY MOUNTING
5	DCCE10012	SHIELD – BATTERY EDGE – RIGHT SIDE
6	HCTF0416	M4X16MM THREAD FORMING SCREW FOR PLASTIC
7	DCCE10013	SHIELD – BATTERY EDGE – LEFT SIDE
8	DCCEMU001	BLOCK OFF – CONNECTOR – BATTERY
9	ZCCEMUOR4	O’RING – BATTERY BLOCK OFF CAP
10	DCCE10005	OVERLAY – BATTERY USER INTERFACE
11	DCCE10008	COMPRESSION LIMITER – FRONT BATTERY MOUNT
12	DCCE10007	GROMMET – FRONT BATTERY MOUNT
13	HCNW0601	6MM SPINNING WASHER NUT – 19MM OD (3 REQ'D)

Chargers:

Low Power 60V & 50V: DAMU6003MP
 High Power 60V & 50V: DAMU6012MP

Parts – Coolant System

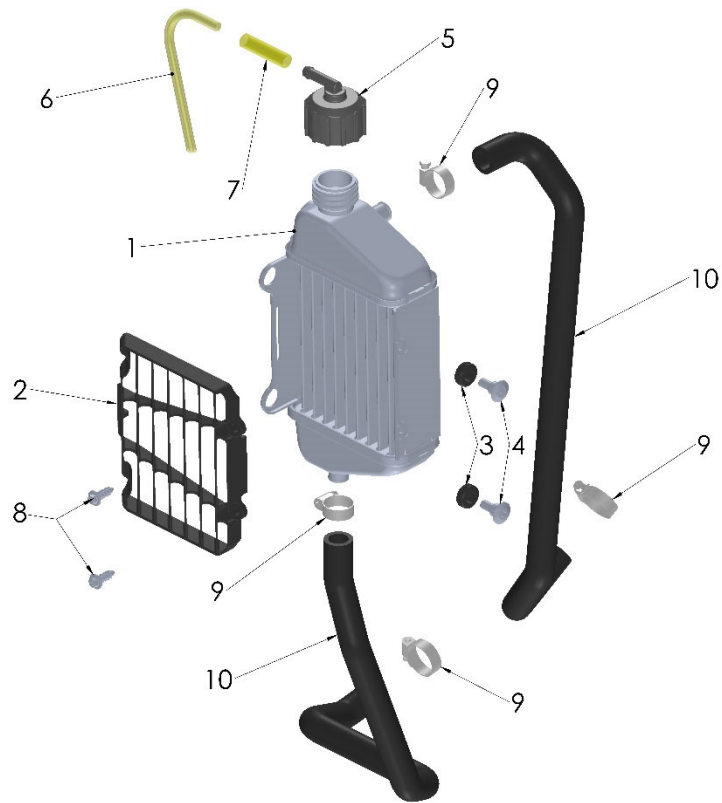

Coolant System		
REF #	PART #	DESCRIPTION
1	FCCE50012	RADIATOR
2	FCMU0069	LOUVER
3	MCMUGR12	GROMMET – RADIATOR MOUNTING (2 REQ'D)
4	HCSP0610	FASTENER – RADIATOR MOUNTING (2 REQ'D)
5	FCMU0020	CAP, 1.3 BAR
6	FCMU0113	RADIATOR OVERFLOW HOSE, 20"
7	FCMU0322	HOSE – USED AS CLAMP
8	HCSP0004	PLASTIC SCREW
9	MCMUCL09	HOSE CLAMP – 11 TO 20MM (4 REQ'D) AT RADIATOR
10	FKEMU001	KIT – HOSE – BLK

Parts – Electrical System

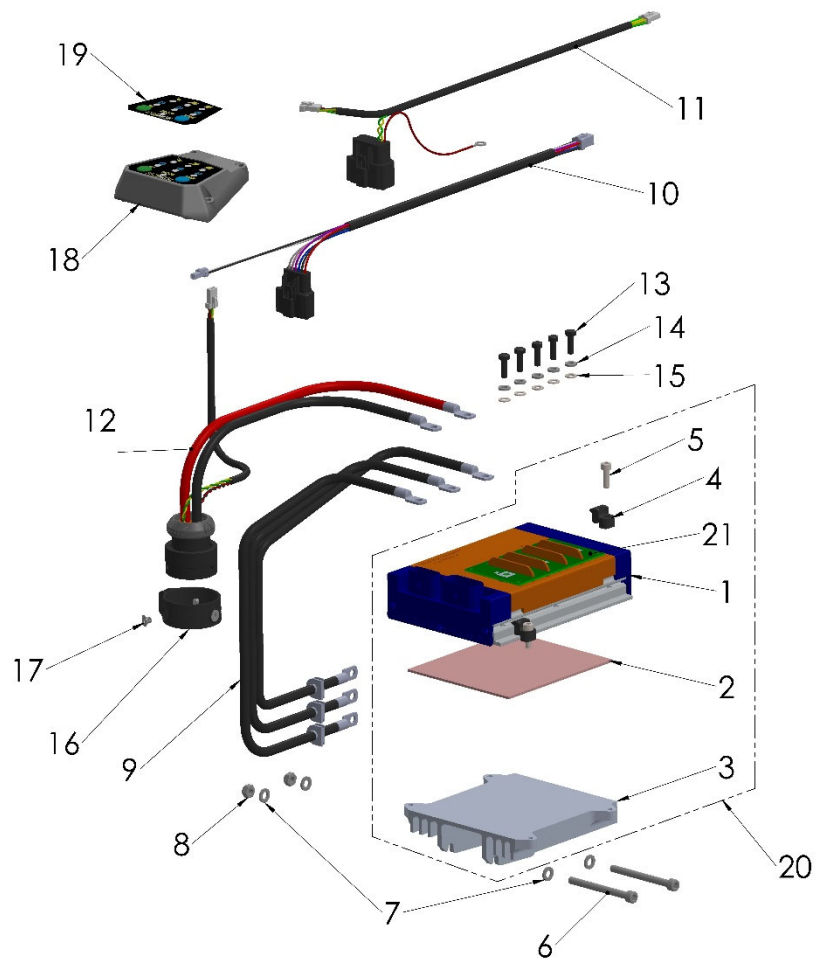

Electrical System		
REF #	PART #	DESCRIPTION
1	JCCE50003	CONTROLLER – MOTOR
2	NCMU0001	THERMAL PAD – HEAT SINK TO CONTROLLER
3	FCCE50016C	MOUNT – CONTROLLER
4	FCCE50019	CLAMP – CONTROLLER MOUNT (4 PCS)
5	HCBC0516	M5X16MM SHCS or HCBF0516 SELF TAPPER (depends if socket head cap screw or hex head with flange)
6	HCBC0665	M6X65MM SHCS
7	HCWF0601	M6 FLAT WASHER (4 REQ'D)
8	HCNL0601	M6 NYLOCK NUT
9	JCCE50058MP	MDU PHASE WIRE, WITH TERMINATIONS – CX5E ONLY
10	JCCEMU006	HARNESS - HALL SENSORS – CX5E ONLY
11	JCCE50065	HARNESS – CAN / COMMUNICATION - JST
12	JCCE1001MP	POWER LEADS FOR MDU
13	HCBH0512	M5X12MM HEX HEAD BOLT(5 PCS)
14	HCWF0501	M5 LOCK WASHER (5 PCS)
15	HCWL0501	M5 FLAT WASHER (5 PCS)
16	TCCE50005	HELPER – BATTERY CONNECTION
17		#10-32 FLAT HEAD SCREW - SHORT
18	VACEMU001MP	RDU – RIDER DISPLAY UNIT
19	VCCEMU004	OVERLAY - RDU
20	JACE50007	CONTROLLER ASSY - WITH PAD ON MOUNT
21	JCCE50059	PCB ASSY - MDU PHASE BIAS - POST BLOCKER

Parts – Electronics Box

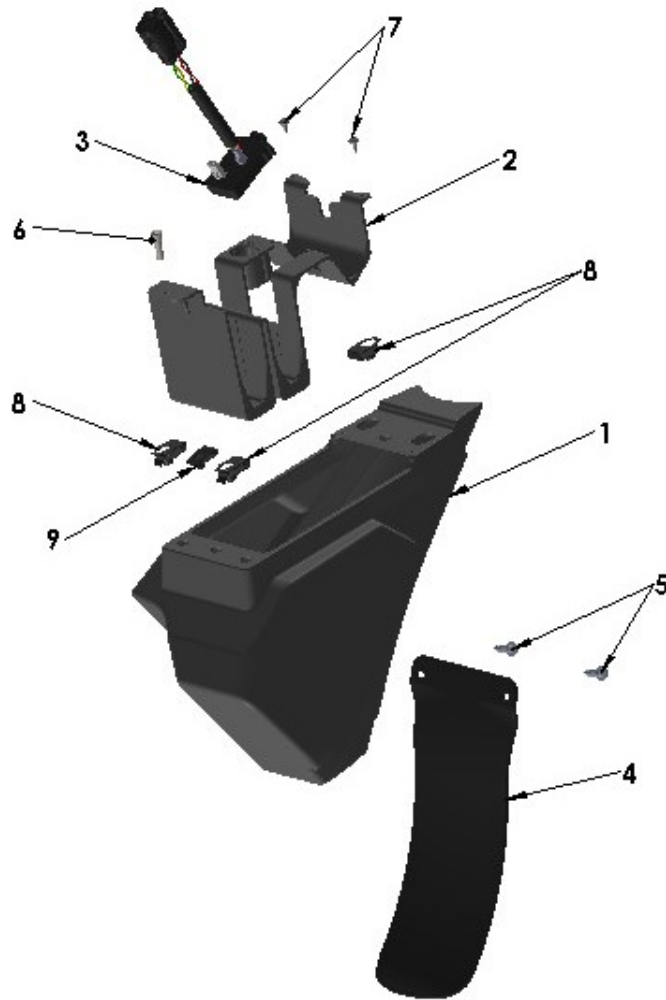

Air Box		
REF #	PART #	DESCRIPTION
1	TCCE50002P	ELECTRONICS BOX
2	JCCE50062	ELECTRONICS HANGER
3	JCCE50064	CAN NETWORK NODE MODULE W/ DIAGNOSTIC PORT (CNN Module) – JST – CX5E
4	TCC60008	MUDFLAP
5	HCSP0004	PLASTIC SCREW
6	HCBC0516	M5X 16 SHCS
7	HCPP0739	PLASTIC SCREW
8	HCHA0003	M6 CLIP NUT
9	HCCN0001	M5 CLIP NUT

Parts – Forks & Triple Clamps

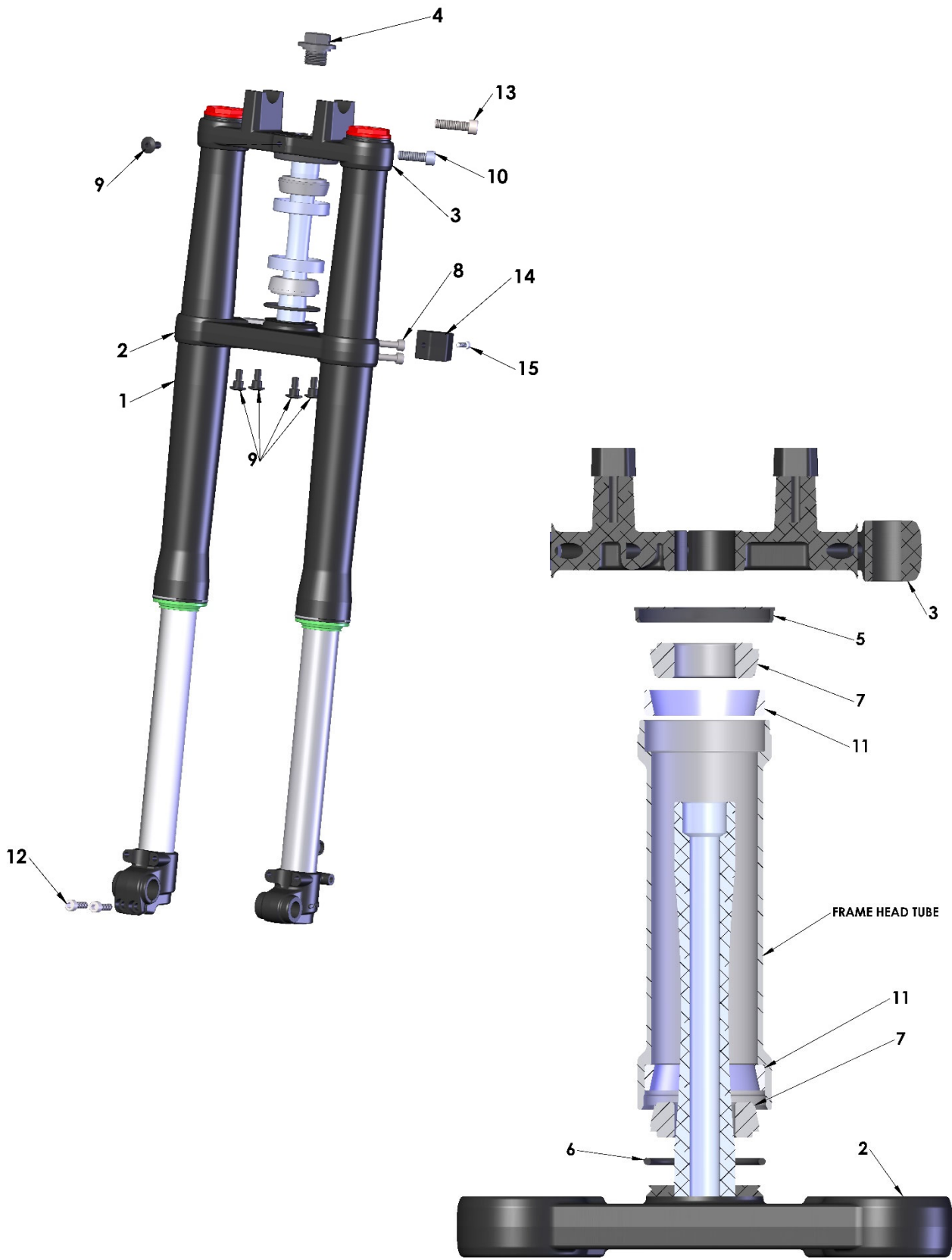

Front Forks and Triple Clamp		
REF #	PART #	DESCRIPTION
1	KACS2021FWE	FORK COMPLETE, BRAKE & NON-BRAKE SIDE
2	FAMU0020BLK	TRIPLE CLAMP BOTTOM ASSY, (CLAMP & STEM) BLACK
3	FCMU0071BLK	TRIPLE CLAMP TOP - BLACK
4	FCMU0074	BOLT – STEERING STEM
5	FCMU0079	DUST COVER (1 REQ'D)
6	FCMU0044	O-RING (1 REQ'D)
7	FCMU0004	STEERING HEAD BEARING (2 REQ'D)
8	HCBC0625	M6X25mm SOCKET HEAD CAP SCREW
9	HCSP0610BLK	BOLT - FORK GUARD - BLACK (NUMBER PLATE & FENDER)
10	HCBC0825	M8 x 25mm SOCKET HEAD CAP SCREW
11	FCMU0011	RACE – STEERING STEM BEARING (2 REQ'D)
12	HCBC0620	M6X20MM SOCKET HEAD CAP SCREW (2 REQ'D)
13	HCBC0830	M8x 30 SHCS
14	FCMU0175MP	STEERING STOP BUMPER (2 REQ'D)
15	HCBB1416	M4x 16 BUTTON HEAD (2 REQ'D)
ACCESSORY	FKMU0008	KIT – STEERING STEM BEARINGS, RACES AND SEALS
TOOL	MCMUTL44	TOOL – BEARING AND SEAL INSTALLER ASSY

Parts – Forks – Leg Assembly – Brake Side

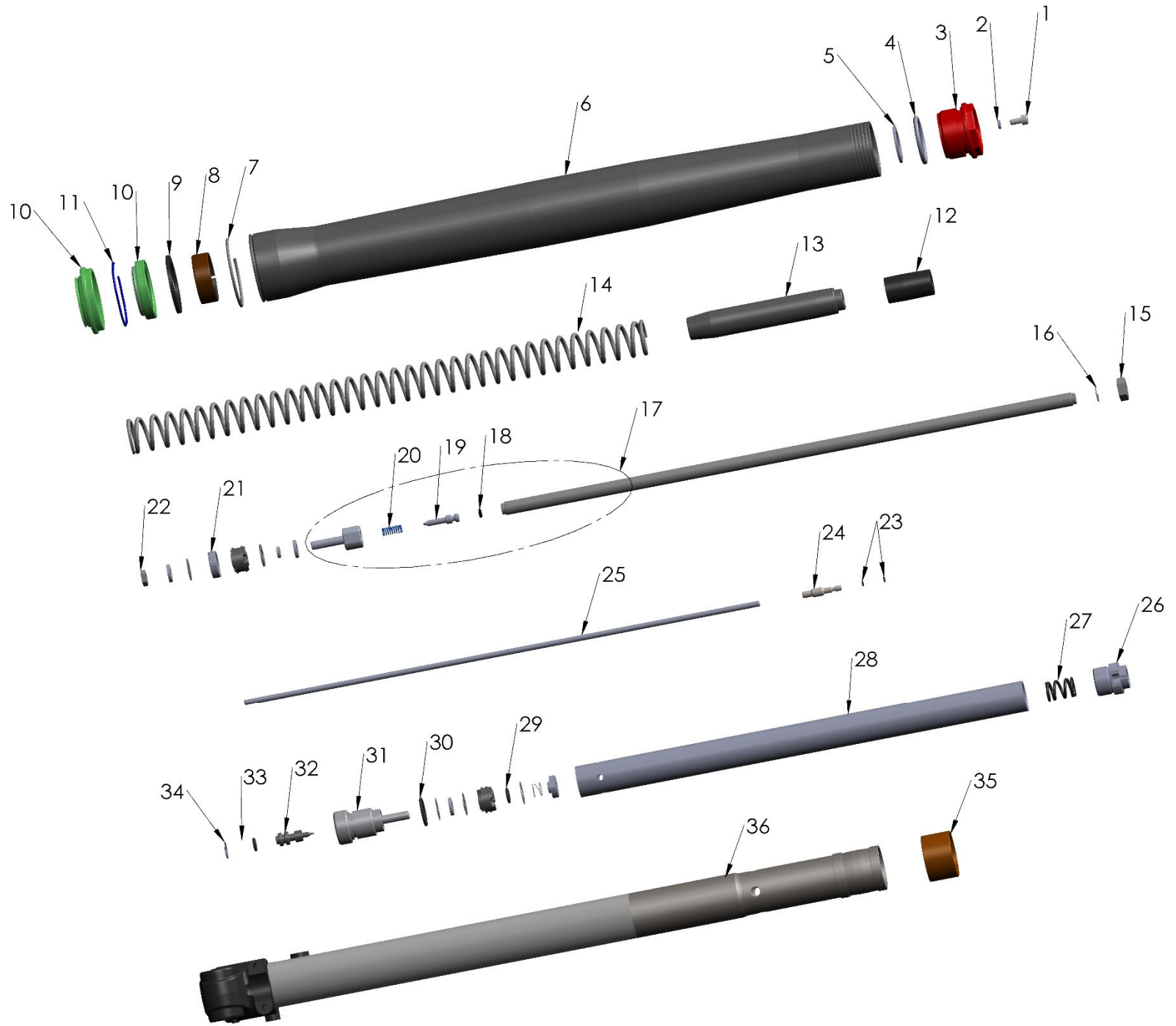

Parts – Forks – Leg Assembly – Brake Side

REF #	PART #	DESCRIPTION
1	HCBC0408	4 X 8 SHCS CLEAR ZINC
2	ZCKG0001	GASKET, BLEED SCREW FORK
3	KCCS0004C	FORK CAP - CONVENTIONAL 32MM USD
4	ZCMUOR18	O-RING – 3MM X 27MM ID
5	KCCS0036	SPRING WEAR PLATE 32MM
6	KCCS0005	OUTER TUBE 32MM
7	KCCS0035	RING CLIP FORK OUTER WEAR RING 32MM
8	KCCS0006	FORK GLIDE RING BOTTOM 32MM
9	KCCS0032	FORK SEAL SPACER 32MM
10	KKCS0004	FORK SEAL AND SWIPER KIT 32MM
11	KCCS0002	RING CLIP - FORK SEAL RETAINER - 32MM
12	KCC60067	JOUNCE BUMPER
13	KCCS0013	SPRING GUIDE 32MM
14	KCCS3225	STANDARD SPRING - FORK 0.25 KG/MM 32mm
14	KCCS3223	LIGHT SPRING - FORK 0.23 KG/MM 32mm
14	KCCS3227	HEAVY SPRING - FORK 0.257KG/MM 32mm
15	HCNJ3824	NUT JAM 3/8-24 CLASS 8
16	KCC60068	RING CLIP - FORK SPRING GUIDE RETAINER
17	KAC60003	DAMPER ROD ASSEMBLY
18	KCC60058	O-RING MID-VALVE ADJ NEEDLE
19	KCC60050	FORK MID-VALVE ADJUSTER NEEDLE
20	KCC60051	SPRING - FORK ADJUSTER NEEDLE
21	KCCS0018	SEAL - FORK PISTON - MID VALVE
22	HCNJ0601	6MM JAM NUT
23	BCKG0033	O-RING – 2MMID
24	KCCS0033	ADJUSTER SCREW TOP 32MM
25	KCC60049	ADJUSTER PIN
26	KCMU0013	CARTRIDGE CAP
27	KCKG0050	TOP OUT SPRING
28	KCKG0019	CARTRIDGE TUBE
29	KCMU0021	O-RING - FORK - BASE VALVE
30	ZCKGB017	O-RING - FORK BOTTOM PLUG
31	KCC60069	FORK BOTTOM PLUG – ADJUSTABLE
32	KCC60048	ADJUSTMET SCREW – FORK BOTTOM PLUG
33	ZCMUOR03	O-RING – ADJUSTMENT SCREW
34	KCCS0031	RING CLIP – FORK ADJUSTMENT SCREW
35	KCCS0007	FORK GLIDE RING
36	KAMU0003BLK	FOR LOWER – COMPLETE – BRAKE SIDE - BLK
TOOL	MCMUTL39	TOOL – FORK SEAL / SWIPER DRIVER – 32MM
TOOL	MCMUTL32	TOOL – FORK CAP WRENCH – 32MM
TOOL	MCMUTL04	TOOL – CARTRIDGE TUBE WRENCH

Parts - Forks – Leg Assembly – Non-brake Side

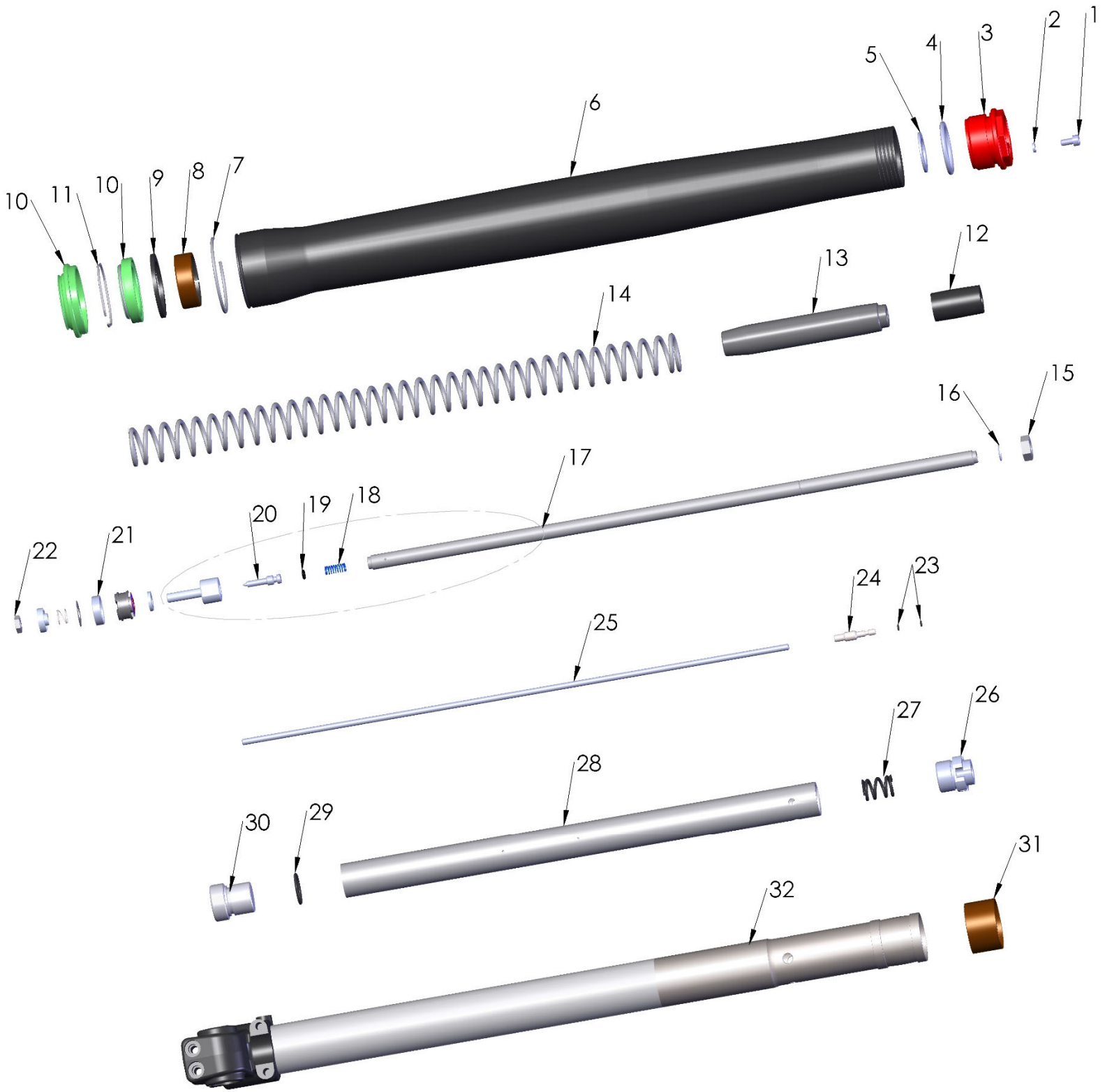

Parts - Forks – Leg Assembly – Non-brake Side

REF #	PART #	DESCRIPTION
1	HCBC0408	4 X 8 SHCS CLEAR ZINC
2	ZCKG0001	GASKET, BLEED SCREW FORK
3	KCCS0004S	CAP - CONVENTIONAL 32MM USD
4	ZCMUOR18	O-RING – 3MM X 27MM ID
5	KCCS0036	WEAR PLATE - FORK SPRING 32MM
6	KCCS0005	OUTER TUBE 32MM
7	KCCS0035	RING CLIP FORK OUTER WEAR RING 32MM
8	KCCS0006	GLIDE RING BOTTOM 32MM
9	KCCS0032	SEAL SPACER 32MM
10	KKCS0004	FORK SEAL AND SWIPER KIT 32MM
11	KCCS0002	RING CLIP - FORK SEAL RETAINER - 32MM
12	KCC60067	JOUNCE BUMPER
13	KCCS0013	SPRING GUIDE 32MM
14	KCCS3225	STANDARD SPRING - FORK 0.25 KG/MM 32mm
14	KCCS3223	LIGHT SPRING - FORK 0.23 KG/MM 32mm
14	KCCS3227	HEAVY SPRING - FORK 0.257KG/MM 32mm
15	HCNJ3824	NUT JAM 3/8-24 CLASS 8
16	KCC60068	RING CLIP - FORK SPRING GUIDE RETAINER
17	KAC60003	DAMPER ROD ASSEMBLY
18	KCC60058	O-RING MID-VALVE ADJ NEEDLE
19	KCC60050	MID-VALVE ADJUSTER NEEDLE
20	KCC60051	SPRING - FORK ADJUSTER NEEDLE
21	KCCS0018	SEAL - FORK PISTON - MID VALVE
22	HCNJ0601	6MM JAM NUT
23	BCKG0033	O-RING – 2MMID
24	KCCS0033	ADJUSTER SCREW TOP 32MM
25	KCC60049	ADJUSTER PIN
26	KCMU0013	CARTRIDGE CAP
27	KCKG0050	TOP OUT SPRING
28	KCC60056	CARTRIDGE TUBE
29	KCMU0021	O-RING - FORK - BASE VALVE
30	KCC60057	PLUG – FORK BOTTOM – SMART LEG
31	KCCS0007	FORK GLIDE RING
32	KAMU0004BLK	FOR LOWER – COMPLETE – NON-BRAKE SIDE - BLK
TOOL	MCMUTL39	TOOL – FORK SEAL / SWIPER DRIVER – 32MM
TOOL	MCMUTL32	TOOL – FORK CAP WRENCH – 32MM
TOOL	MCMUTL04	TOOL – CARTRIDGE TUBE WRENCH

Parts – Frame & Subframe

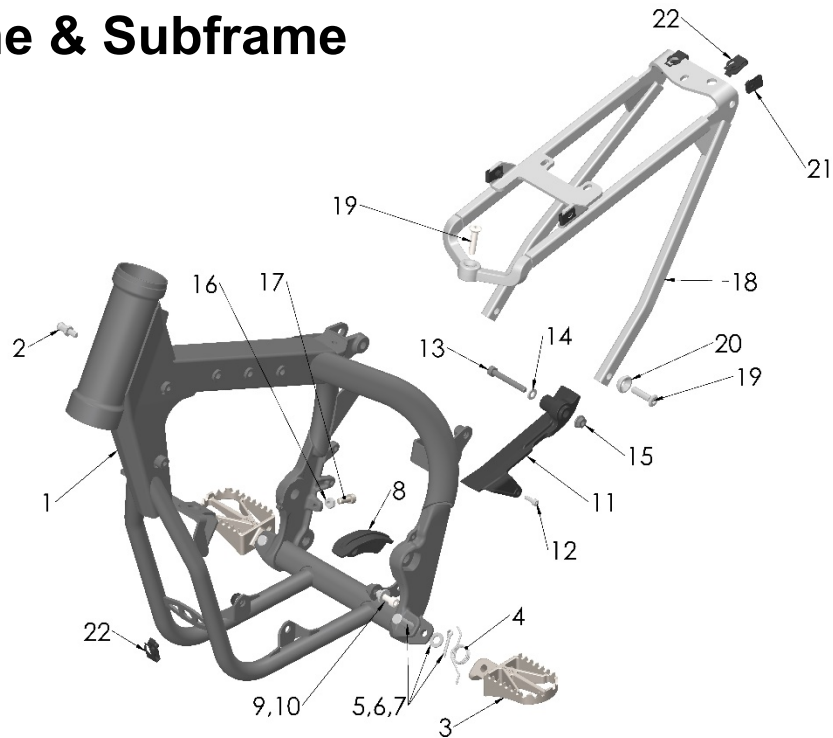

Frame		
REF #	PART #	DESCRIPTION
1	FACE52024	FRAME – 2024 FWE
2	FCCE50015	POST – SIDE LOUVER
3	TCMU0139	FOOTPEGS (PAIR)
4	TCC60012	SPRING - FOOTPEG (SINGLE PIECE)
5	FCMU0031	CLEVIS PIN - FOOTPEG
6	HCWF0801	8mm FLAT WASHER
7	HCCP0008	COTTER PIN 1/8 X 3/4
8	TCMU0044	LOWER CHAIN SLIDE
9	HCBC0616	M6X16 SOCKET HEAD CAP SCREW
10	TCC60019	COMPRESSION LIMITING SPACER
11	FCCEMU001	CHAIN SLIDE – MOLDED
12	HCBC0412	M4X12MM SHCS
13	HCBC0645	M6X45MM SHCS
14	HCWF0601	M6 FLAT WASHER
15	HCNL0601	M6 NYLOCK FLANGE NUT
16	HCBC0625	BRAKE ADJUSTER BOLT
17	HCNS0601	6MM NUT
18	FACE5001	SUBFRAME - CXe
19	HCSP0701	SPROCKET BOLT – M7
20	FCMU0109	COMPRESSION LIMITER – SUB FRAME
21	HCCN0001	M5 CLIP NUT (4 REQ'D)
22	HCHA0003	6MM CLIP NUT (2 PLACES)

Parts – Front Brakes

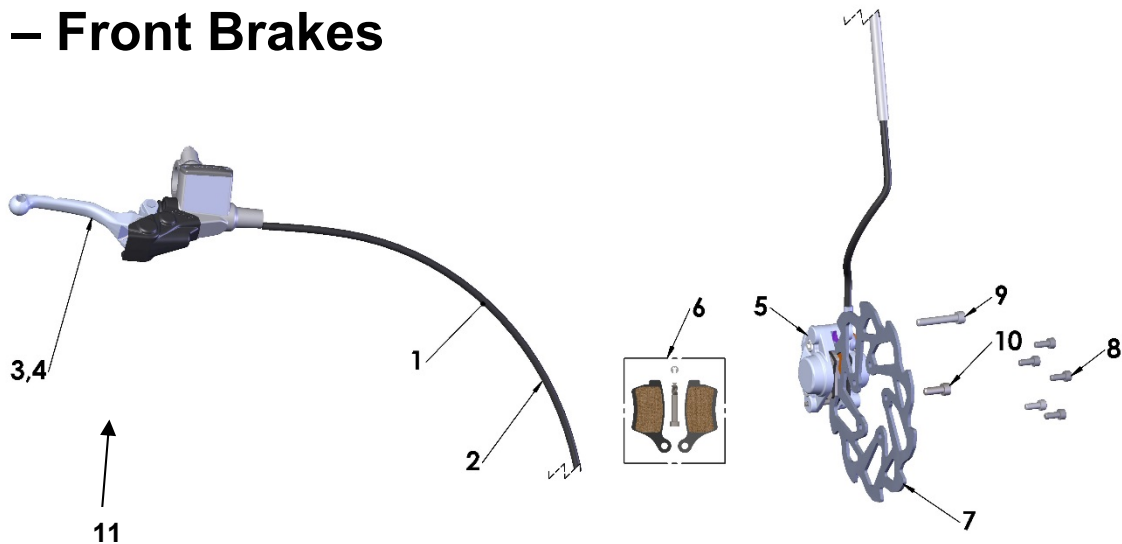

Front Brakes		
REF#	PART #	DESCRIPTION
1	BACS0001	BRAKE ASSY - FRONT CARD - KING FW - 2 PISTON 11.0
2	BCCS0003	HOSE – BRAKE FRONT
3	BAMU0009	LEVER ASSEMBLY
4	BAMU0006	MASTER CYLINDER ASSEMBLY COMPLETE W LEVER
5	BAMU0020	CALIPER – FRONT – CARD 2 PISTON
6	BKMU0009	KIT 505 ORGANIC BRAKE PADS, WITH BOLT AND CLIP
7	BCMU0222	BRAKE ROTOR
8	HCBC0514	M5X14mm SOCKET HEAD CAP SCREW (5 REQ'D)
9	HCBC0635	M6X35mm SOCKET HEAD CAP SCREW
10	HCBC0620	M6X20mm SOCKET HEAD CAP SCREW
11	BCMU0116	COVER – MUD PROTECTION
Caliper Accessories		
ACCESSORY	BKMU0003	BLEED KIT (MULTIPLE SYRINGES, FITTINGS & HOSE)
ACCESSORY	BCMU0038	SPRING - BRAKE PAD RETURN
ACCESSORY	BKMU0006A	PISTON & SEAL KIT – CARD CALIPER - ALUMINUM
ACCESSORY	BKMU0008	BLEED SCREW KIT – CARD
ACCESSORY	BKMU0007	BANJO BOLT AND WASHER KIT – CARD
ACCESSORY	BCMU0014	CALIPER ADJUSTMENT SHIMS 6mm ID
Master Cylinder Accessories		
ACCESSORY	BKC60008	CAP & BLADDER KIT ZL150 (CAP, BLADDER & (2) M3-0.5 X 6mm LONG PHILLIPS SCREW)
ACCESSORY	BCC60058	CLAMP – M/C ZL150
ACCESSORY	HCBC0620	M6-1.0 X 22mm SOCKET HEAD CAP SCREW
ACCESSORY	BCMU0060	PIVOT BOLT
ACCESSORY	BCC60017	BOOT – PISTON END COVER
ACCESSORY	BKC60015	REBUILD KIT – MASTER CYLINDER CARD 11.0MM (PISTON, SEALS, BUSHING, SPRING, CLIP & RETAINING WASHER)
ACCESSORY	HCSS0520	M5 X 20 SET SCREW – LEVER POSITION ADJUSTMENT
ACCESSORY	HCNJ0501	5MM LOCKNUT
ACCESSORY	CKC60005	PIVOT BOLT KIT – LEVER TO PIVOT BLOCK – MALE & FEMALE
ACCESSORY	HCSS0610	SET SCREW – PRESET
ACCESSORY	BCMU0059	LEVER ONLY – THIN FORMLY
ACCESSORY	CCC60026	SPRING – LEVER RETURN
ACCESSORY	CCC60025	SPACER – SPRING CENTERING

Parts – Front Wheel

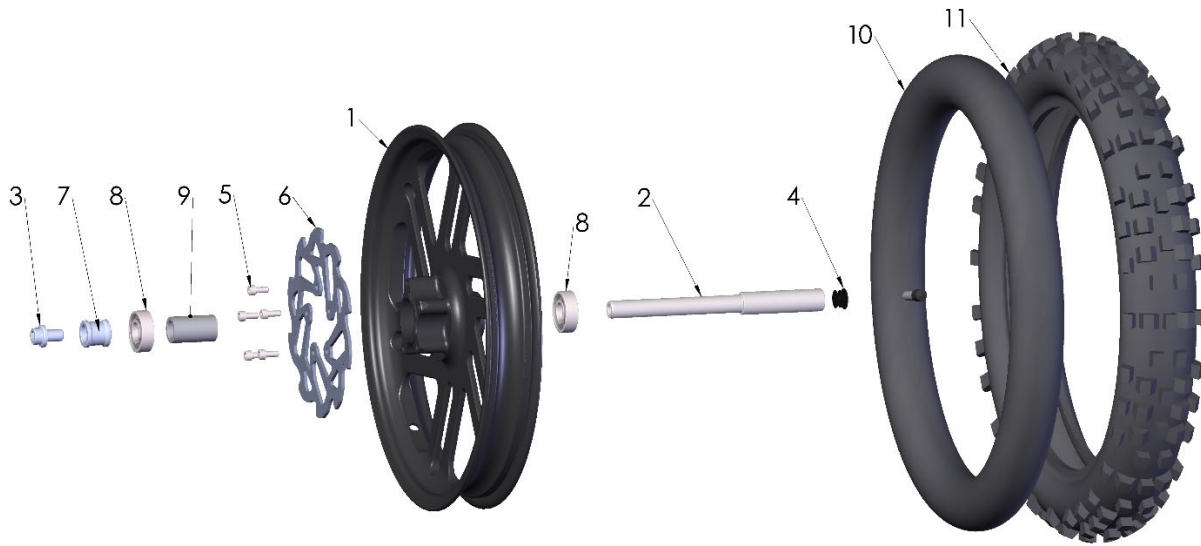

Front Wheel		
REF #	PART #	DESCRIPTION
1	WACSF021BLK	WHEEL WITH BEARINGS SPOKE STYLE – BLACK ANODIZE
2	WCMU0043	FRONT AXLE - HOLLOW
3	HCSP1016BLK	BOLT – ALUMINUM AXLE PULL – BLACK ANODIZE
4	WCMU0024	PLUG - BLACK PLASTIC
5	HCBC0514	M5X14mm SOCKET HEAD CAP SCREW (5 REQ'D)
6	BCMU0222	BRAKE ROTOR – FRONT & REAR
7	WCMU0045BLK	WHEEL SPACER LEFT
8	WCMU0120	BEARING – WHEEL (2 REQ'D)
9	WCMU0044	SPACER – WHEEL FRONT
10	WCKG1201	TUBE 12"
11	WCKG1200D34	TIRE - FRONT - 60/100-12- DUNLOP MX34

Parts – Motor System - Internals

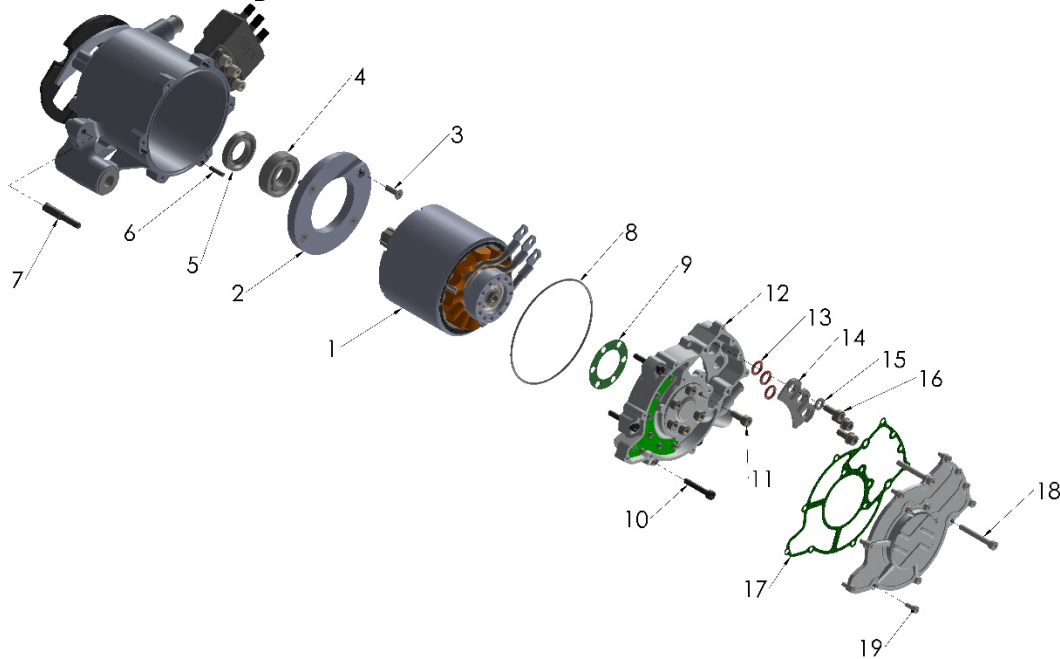

Motor System		
REF #	PART #	DESCRIPTION
1		MOTOR - NOT SOLD SEPARATELY
2	JCCE50038	STUFFER – PUMP
3	HCFH0516	M5X16MM FLAT HEAD SCREW (4 REQ'D)
4	ECKGBR01	BEARING – OUTPUT
5	JCCE50031	SEAL - OUTPUT
6	ECDC0051	DOWEL PIN 4X16 (3 REQ'D)
7	DCCE10011	STUD – REAR BATTERY MOUNT – M8 / M6
	ECC60107	STUD – REAR BATTERY MOUNTING M6
8	ZCCE50R03	O’RING – CASE SEALING
9	ZCCE50002	GASKET – STATOR TUBE TO CASE
10	HCBC0540	M5X40MM SHCS (2 REQ'D)
11	HCBC0530	M5X30MM SHCS (4 REQ'D)
12	JCCEMU001	HOUSING – MOTOR – WIRE SIDE
13	ZCCEMUOR1	ORING – PHASE STUDS
14	JCCE50037	INSULATOR – PHASE
15	HCWF0601	M6 FLAT WASHER (3 REQ'D)
16	HCBC0601	M6X16MM SHCS (3 REQ'D)
17	ZCCEMU001	GASKET – PHASE COVER TO CASE
18	HCBC0540	M5X40MM SHCS (2 REQ'D)
19	HCBC0410	M4X10 SHCS (9 REQ'D)
	HCBC0408	M4X8 SHCS (4 REQ'D) IN THE CENTER
	See Rear Brake	BRAKE SNAKE ON BRACKET
ACCY	MCMUMF32	MOTOR COOLING FLUID – 32OZ BOTTLE

Parts – Motor System – Sprocket Side

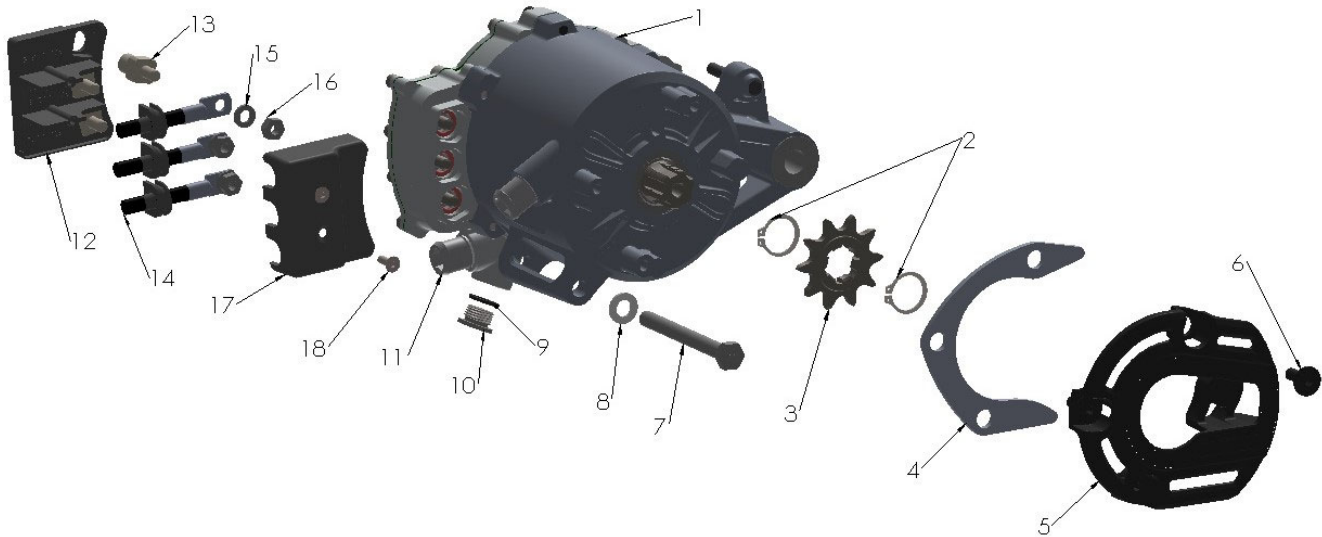

Motor System		
REF #	PART #	DESCRIPTION
1	JACEMU002	MOTOR ASSEMBLY – COBRA – SMALL VEHICLE
2	ECKGSR03	SNAP RING – OUTPUT SHAFT (2 REQ'D)
3	PCMU0010	SPROCKET – FRONT – 10T – 415 CHAIN
4	JCCEMU005	GUARD – MOTOR CASE SAVER
5	JCCEMU023	GUARD – SPROCKET - 2025
6	HCSP0610BLK	BOLT – FORK GUARD – 6MM ALUM – BLACK (3 REQ'D)
7	HCBH0880	M8 X 80MM HEX HEAD
8	HCWF0801	8MM FLAT WASHER
9	ZCMUB014	O’RING – COOLANT DRAIN
10	ECMU0272	PLUG – COOLANT DRAIN
11	ECMU0132	FITTING - COOLANT
12	JCCE50036	SPACER – INSULATING – PHASE LEADS
13	JCCE50035	STUD – PHASE – RING LUG STYLE (3 REQ'D)
14	SEE ELECTRICAL	PHASE LEADS
15	HCWF0601	6MM FLAT WASHER (3 REQ'D)
16	HCNS0601	M6 NUT DIN 934 CLASS 8
17	JCCE50044	CAP – SPACER – PHASE LEAD INSULATING
18	HCFH0412	M4 X 12MM FLAT HEAD (2 REQ'D)
19		
ACCY	MCMUMF32	MOTOR COOLING FLUID – 32OZ BOTTLE

Parts – Motor System – Wire Side

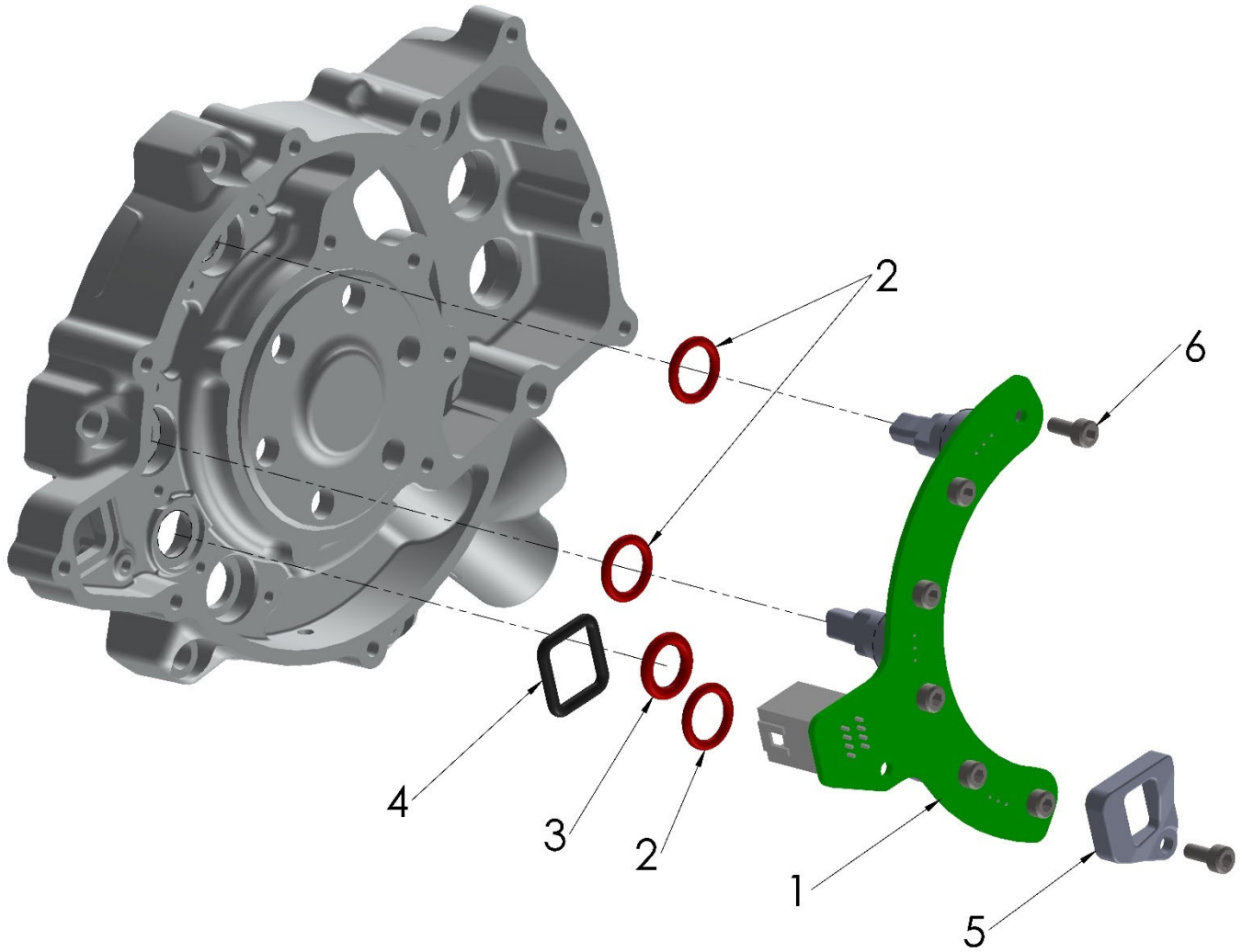

Motor System		
REF #	PART #	DESCRIPTION
1	JKEMU001	KIT – V2 MOTOR SENSOR MODULE – W/ ORINGS
2	ZCCEMUOR1	O’RING – MOTOR HOUSING (3 REQ’D) – FOR V1 MOTOR SENSOR MODULE
2	ZCCEMUOR05	O’RING – MOTOR HOUSING (3 REQ’D) – FOR V2 MOTOR SENSOR MODULE
3	ZCCEMUOR2	O’RING – TEMP SENSOR PASS THRU
4	ZCCEMUOR3	O’RING – JST CONNECTOR PASS THRU
5	JCCEMU007	PRESSURE PLATE – HALL SENSOR BOARD
6	HCBC0308	M3X8MM SHCS (7 REQ’D)
ACCY	MCMUMF32	MOTOR COOLING FLUID – 32OZ BOTTLE

Parts – Plastic Bodywork & Seat

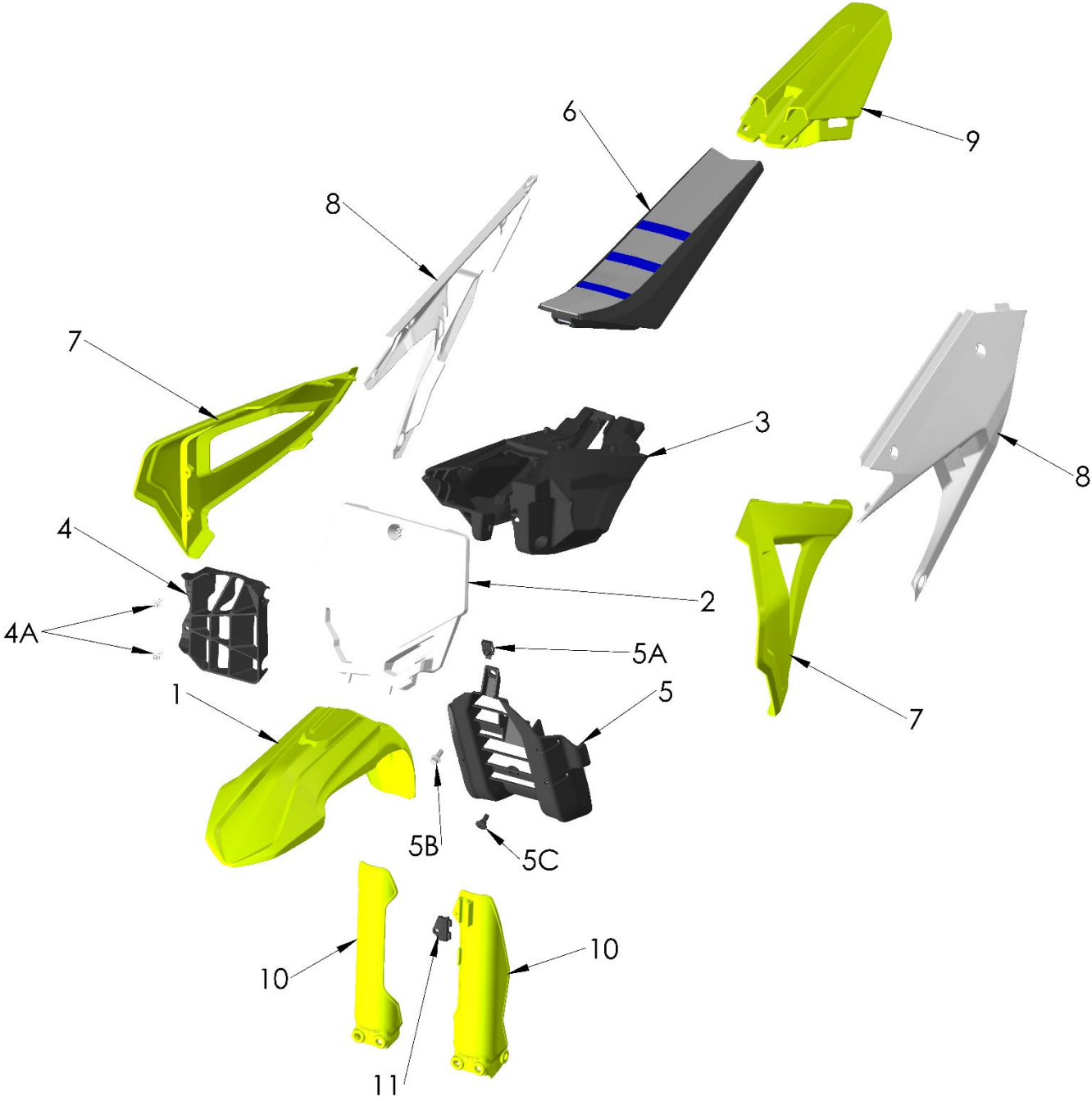

Parts – Plastic Bodywork & Seat

Plastic and Seat		
REF #	PART #	DESCRIPTION
1	TCCS0009FXX	FRONT FENDER – FXX YELLOW
1	TCCS0009x	FRONT FENDER x – DENOTES COLOR BLK, WHT, YEL, FXX
1A	HCBF0616	FRONT FENDER MTG BOLTS (4 REQD)
2	TCMU0041WHT	FRONT NUMBER PLATE – WHITE
2	TCMU0041x	FRONT NUMBER PLATE x – DENOTES COLOR BLK, WHT, YEL
2A	HCBF0616	M6X16mm FLANGE HEAD BOLT – FRONT NUMBER PLATE MOUNT
3	TCCE50001	TANK REPLACEMENT – DASH PANEL MOUNT
3A	TCMU0047	BUSHING - FRONT TANK MOUNT
3B	TCMU0017	BUSHING – SQUARE THREADED - FRONT TANK MOUNT
3C	TCC60029	SPACER – SEAT MOUNT
3D	HCFH0620	M6X20mm FLAT HEAD – FRONT SEAT MOUNT
3E	HCFH0675	M6X75mm FLAT HEAD
4	TCCE50003	LOUVER – SIDE SCOOP
4A	HCSP0004	PLASCREW – SHROUD TO TANK (2 REQ'D)
5	TCCE50004	LOUVER – FRONT GRILL
5A	HCHA0003	M6 CLIP NUT (2 REQ'D)
5B	HCBF0616	M6 X 16MM FLANGE BOLT
5C	HCSP0610BLK	BOLT – 6MM ALUMINUM
6	TACE52025	SEAT ASSY – CXE5
6A	TCCE50007	COVER – SEAT – CXE5
6B	TCMU0046BLK	SPECIAL WASHER – SEAT HOLDING - BLACK
6C	HCFH0650	M6X50 FLAT HEAD, REAR MOUNTING BOLT
7	TCMU0043FXX	SHROUD FXX YELLOW
7	TCMU0043x	SHROUD x – DENOTES COLOR BLK, WHT, YEL, FXX
7A	HCSP0004	PLASCREW – SHROUD TO TANK (4 REQ'D)
8	TCCS0011WHT	NUMBER PLATE PAIR – WHITE
8	TCCS0011x	NUMBER PLATE PAIR x – DENOTES COLOR BLK, WHT, YEL
8A	HCBC0502	M5X20 SOCKET HEAD CAP SCREW (2 REQ'D PER SIDE)
8B	TCC60017	BODY PANEL WASHER 5MM (2 REQ'D PER SIDE)
8C	HCCN0000	5MM EXTRUDED “U” NUT
9	TCMU0055FXX	REAR FENDER – FXX YELLOW
9	TCMU0055x	REAR FENDER x – DENOTES COLOR BLK, WHT, YEL, FXX
9A	HCSP0610BLK	BOLT – SPECIAL
9B	HCHA0003	CLIP NUT – 6mm
10	KCMU0035	FORK GUARD SET – 2021
10A	HCSP0610BLK	BOLT - FORK GUARD - BLACK (6 REQ'D,)
11	KCMU0036	BRAKELINE CLAMP
11A	HCSP0004	PLASTIC SCREW (2 REQ'D)
ACCESSORY	TCCE52025	GRAPHIC KIT – CXe5
ACCESSORY	TKFW2025	BODYWORK KIT – MEGA FLO PLASTIC w WHITE # PLATES
ACCESSORY	TKFX2025FXX	BODYWORK KIT – ALL FXX PLASTIC
ACCESSORY	TKFW2025BLK	BODYWORK KIT – ALL BLACK PLASTIC
ACCESSORY	TKFW2025WHT	BODYWORK KIT – ALL WHITE PLASTIC

Parts – Rear Brake

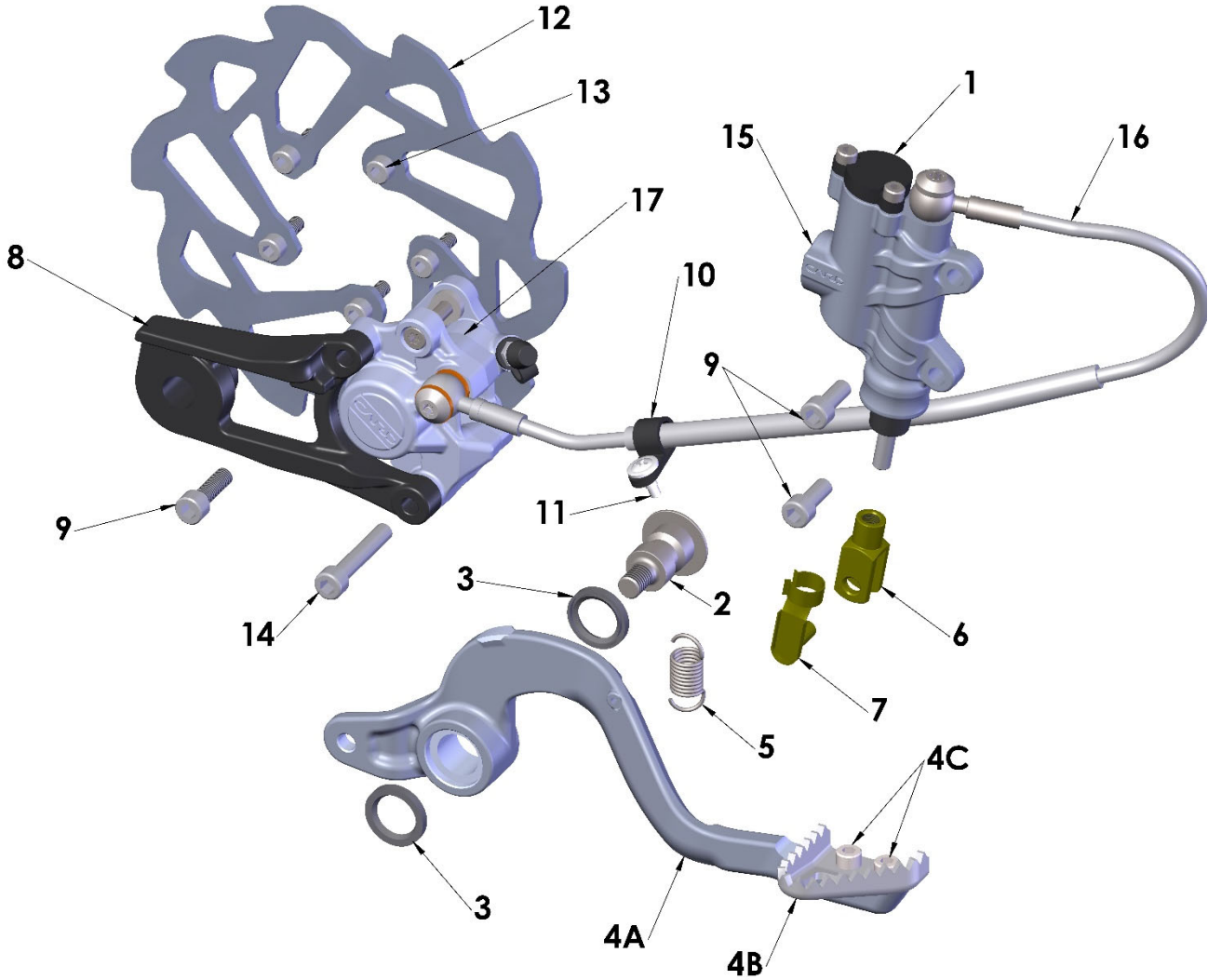

Parts – Rear Brake

Rear Brake System		
REF #	PART #	DESCRIPTION
1	BACS0002	ASSY - REAR BRAKE -CAPTURD CLEVIS -KG FWE 2024 -
2	BCMU0027	BRAKE PIVOT BOLT –
3	BCMU0501	SEAL – BRAKE PEDAL (2 REQ'D)
4A	BCMU0069	BRAKE PEDAL – ASSEMBLY 50cc – WITH TOE PIECE
4B	BCMU0023T	TOE PIECE
4C	HCBC0512	M5X 12mm SOCKET HEAD CAP SCREW
5	BCMUSP01	BRAKE RETURN SPRING
6	BCMU0015A	BRAKE CLEVIS
7	BCMU0015B	BRAKE RETAINING SPRING PIN
8	BCMU0045BLK	BRAKE CARRIER – CARD 2 PISTON – CX50 – BLACK
9	HCBC0620	M6X20mm SOCKET HEAD CAP SCREW
10	HCCC0000	BRAKE HOSE CLAMP
11	HCPP0832	BRAKE HOSE CLAMP FASTENER
12	BCMU0222	BRAKE ROTOR
13	HCBC0514	M5X14mm SOCKET HEAD CAP SCREWS (5 REQ'D)
14	HCBF0635	M6X35mm SOCKET HEAD CAP SCREW
15	BAMU0014	MASTER CYLINDER - REAR - COMPLETE CAPTURED CLEVIS
16	BCMU0047	REPLACEMENT BRAKE HOSE
17	BAMU0010A	CALIPER ASSEMBLY – REAR BRAKE – CARD 2 PISTON - ALUM
18	BKMU0002	ASSY – BRAKE SNAKE
ACCESSORY	BKMU0009	PAD SET ORGANIC W BOLT AND CLIP
ACCESSORY	BCMU0038	SPRING - BRAKE PAD RETURN
ACCESSORY	BKMU0006A	PISTON & SEAL KIT – CARD - ALUMINUM
ACCESSORY	BKMU0008	BLEED SCREW KIT – CARD
ACCESSORY	BCC60034	RUBBER CAP ONLY - BLEED SCREW
ACCESSORY	BKMU0013	CAP & DIAPHRAGM KIT – MASTER CYLINDER
ACCESSORY	BKMU0014	REBUILD KIT - REAR - MASTER CYLINDER - 2024 - CAPTURED
ACCESSORY	BKMU0007	BANJO BOLT AND WASHER KIT – CARD
ACCESSORY	BCMU0014	CALIPER ADJUSTMENT SHIMS 6mm ID
TOOL	BKMU0003	BLEEDING KIT – FORMULA & CARD

Parts – Rear Wheel

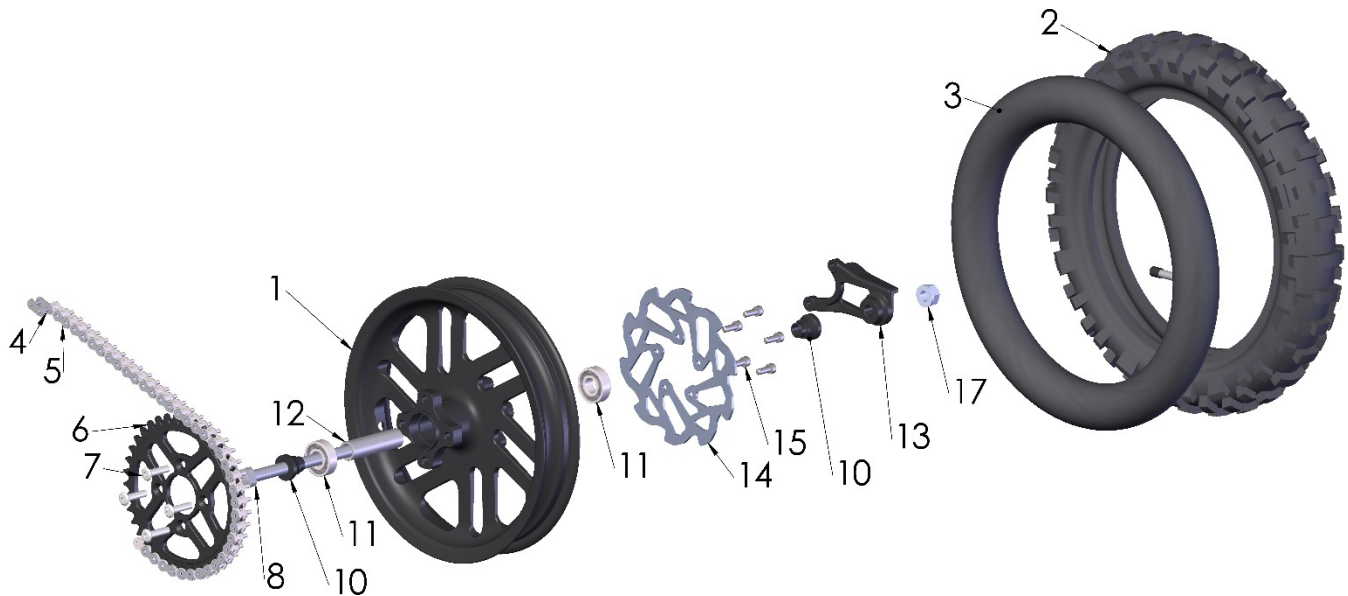

Rear Wheel		
REF #	PART #	DESCRIPTION
1	WAMUR021BLK	REAR WHEEL W/BEARINGS – BLACK
2	WCMU1075D34	TIRE - REAR - 70/100-10 - DUNLOP MX34
3	WCMUTU10	TUBE, 10"
4	PCMU0001	MASTER LINK 420
5	PCMU0110	CHAIN 420 X 110
6	PCC50249BLK	49T SPROCKET (STANDARD) 415 - BLACK
6A	PCC502xx	SPROCKET xx DENOTES TEETH – RANGE OF TEETH (34-45)
7	HCSP0701	M7X30mm SPECIAL HEAD BOLT (4 REQ'D)
7A	HCWF0701	7mm FLAT WASHER (4 REQ'D)
7B	HCNL0701	M7 LOCKNUT (4 REQ'D)
8	GCMU0020	BOLT - TI - SWINGARM PIVOT and AXLE - CX50
10	WCMU0101BLK	WHEEL SPACER (2 REQ'D)
11	WCMU0120	WHEEL BEARING (2 REQ'D)
12	WCMU0041	WHEEL BEARING SPACER
13	BCMU0045	CARRIER – BRAKE
14	BCMU0222	BRAKE ROTOR
15	HCBC0514	M5X14mm SOCKET HEAD CAP SCREWS (5 REQ'D)
17	WCMU0038	NUT - 12MM ACORN - ALUM
ACCESSORY	HKMU0002	BOLT KIT – REAR SPROCKET

Parts – Shock

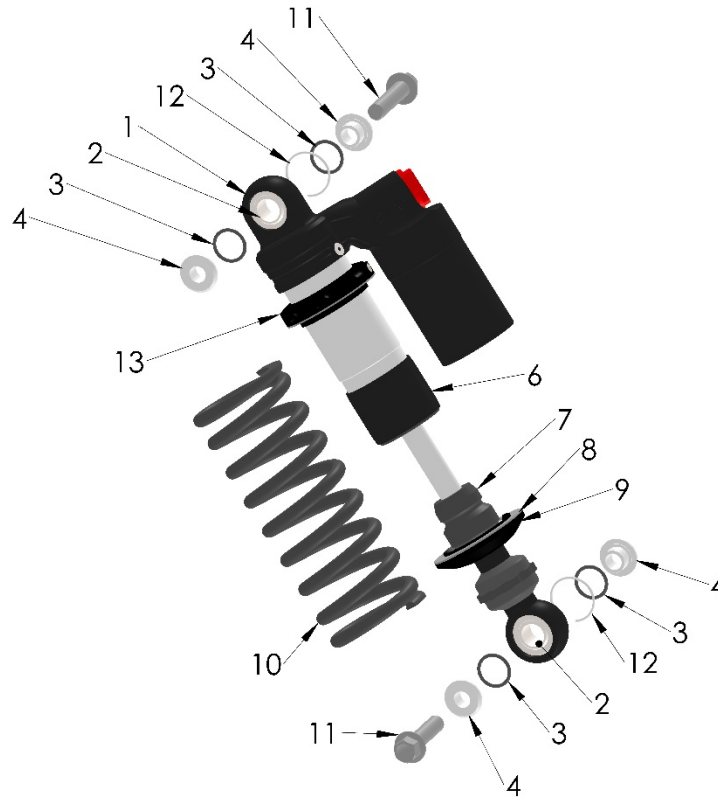

Shock		
REF #	PART #	DESCRIPTION
1	SACS2021	SHOCK ABSORBER – KING
2	SCMU0043	SHOCK - BEARING SPHERICAL SHOCK MOUNT–CARD (2 REQ'D)
3	SCMU0039	O-RING - SHOCK - BUSHING – CARD (4 REQ'D)
4	SCMU0042	SHOCK - MOUNT BUSHING – CARD (4 REQ'D)
5	SCMU0058	SHOCK - WHITE NYLON TIP SETSCREW M6-1.0 - CARD
6	SCMU0056	SHOCK - SLEEVE BLACK - CARD
7	SCMU0008	BUMPER - SOFT - TAPPERED - SHOCK
8	SCMU0040	SHOCK - SPRING PAD - CARD
9	SCMU0054	SHOCK - SPRING PERCH - CARD
10	SCKGFX31	SHOCK SPRING 3.1 KG/MM (STANDARD)
10	SCKGFX29	SHOCK SPRING 2.9 KG/MM (LIGHT)
10	SCKGFX33	SHOCK SPRING 3.3 KG/MM (HEAVY)
10	SCKGFX35	SHOCK SPRING 3.5 KG/MM (XHEAVY)
11	HCBF1039	M10 X 39 HEX HEAD BOLT (2 REQ'D)
12	SCMU0330	CIRCLIP – SPHERICAL BEARING RETAINER
13	SCMU0120	PRELOAD ADJUSTER RING
ACCESSORY	SKMU0003	REBUILD KIT – CARD SHOCK

Parts – Shock - Inside

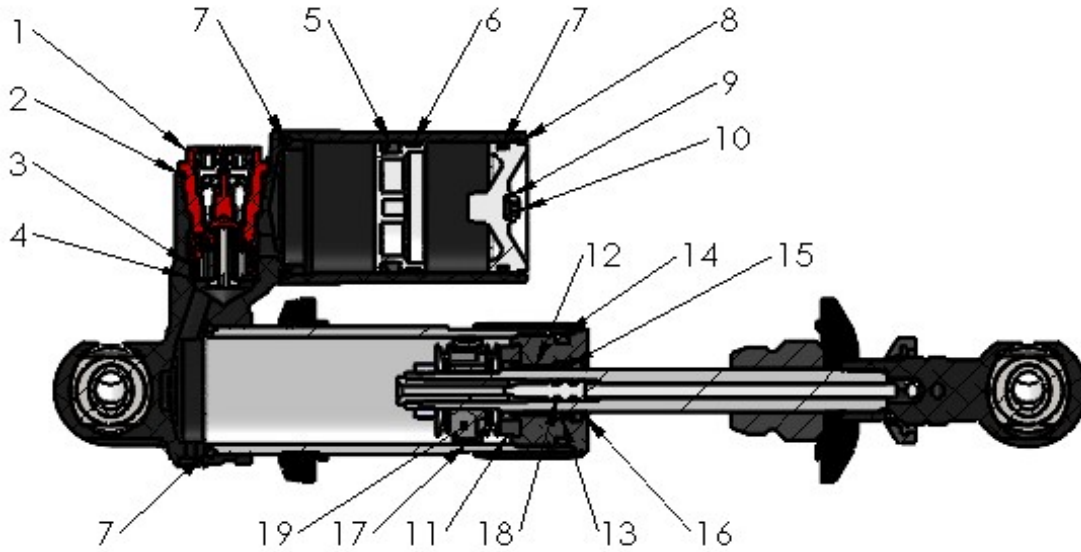

Shock		
REF #	PART #	DESCRIPTION
1	SAMU0001	COMPRESSION ADJUSTER ASSEMBLY – COMPLETE
2	ZCMUB020	O-RING – COMPRESSION ADJUSTER - OUTSIDE
3	KCMU0021	O-RING - COMPRESSION ADJUSTER – PISTON SEAL
4	ZCMUOR37	O-RING - COMPRESSION ADJUSTER - INSIDE
5	SCMU0051	O-RING - IFP
6	SCMU0052	IFP SEAL BAND
7	SCMU0033	O-RING SHOCK BASE
8	SCMU0050	RESERVOIR CAP RETAINER RING
9	SCMU0035	O-RING CHARGE CAP
10	HCBB0506	M5X6mm LONG BUTTON HEAD STAINLESS STEEL
11	SCMU0044	SEAL HEAD BUMPER
12	SCMU0048	SHAFT BUSHING
13	SCMU0046	X-RING SEAL
14	SCMU0034	O-RING SEAL HEAD
15	SCMU0047	SPACER - X-RING
16	SCMU0045	DUST SEAL
17	SCC60014	PISTON BAND
18	SCMU0059	O-RING REBOUND PIN
19	SCMU0091	PISTON - SHOCK
	SCCM0001	SEAL HEAD – WITHOUT COMPONENTS
	SKMU0002	SEAL HEAD - COMPLETE
ACCESSORY	SKMU0003	REBUILD KIT – CARD SHOCK

Parts – Swingarm Assembly

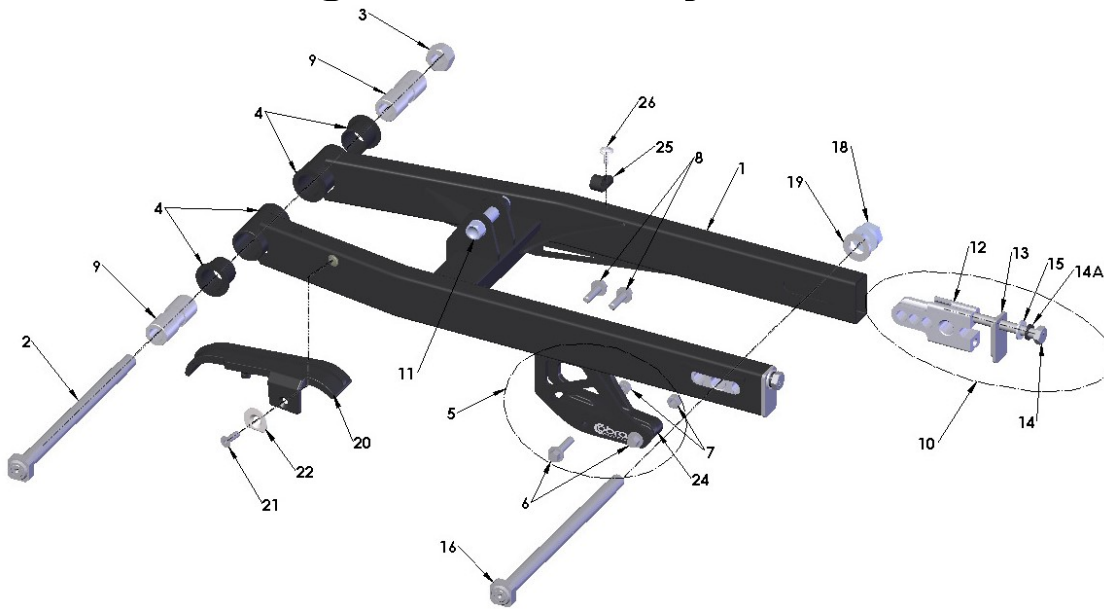

Swingarm		
REF #	PART #	DESCRIPTION
1	GACS2021	SWINGARM
2	GCMU0021	BOLT - TI - SWINGARM PIVOT and AXLE - CX50- shorter
3	HCNL1201	M12 SWINGARM LOCK NUT
4	GCMU0001	SWINGARM BUSHING (4 REQ'D)
5	PAMU0001	CHAIN GUIDE ASSEMBLY COMPLETE – CXe5
5a	PCCEMU001	ROLLER – CHAIN ROLLER
5b	PCCEMU002	SHAFT – CHAIN ROLLER
6	HCBF0625	M6X25mm FLANGE HEAD SCREW (2 REQ'D)
7	HCNL0601	M6 LOCKNUT (2 REQ'D)
8	HCBF0620	M6X20mm FLANGE HEAD BOLT (2 REQ'D)
9	GCCS0015	SWINGARM PIVOT TUBE SPACER 2021 (2 REQ'D)
10	FAMU0005	WHEEL PULL ASSEMBLY (BLOCK, CAP, BOLT AND WASHER)
11	HCBF1039	M10X39mm LOWER SHOCK MOUNT BOLT
12	FCMU0203	WHEEL PULL
13	FCMU0202	WHEEL PULL ENDCAP
14	HCBH1865	M8X65mm WHEEL PULL BOLT
14A	HCWL0801	8mm LOCK WASHER
15	HCWF0801	8mm WHEEL PULL WASHER
16	GCMU0020	BOLT - TI - SWINGARM PIVOT and AXLE - CX50
18	WCMU0038	NUT - 12MM ACORN - ALUM
19	HCWF1202	12mm FLAT WASHER
20	GCMU0041	SWINGARM CHAIN GUARD - CX50 - WITH MOHAWK AND FOOT
21	HCFH0516	FLAT HEAD SCREW
22	GCMU0038	WASHER - SPECIAL
23	HCNL0501	LOCK NUT
24	PCMU0060MP	CHAIN GUIDE - COMBINED SLIDER BOTTOM AND INSIDE
25	HCCC0006	CLAMP - BRAKE HOSE
26	HCPP0832	FASTENER – ½" SELF TAPPING

Service

Trained technicians with precision gauging and proper assembly fixtures carefully assemble all Cobra engines to specific tolerances. If you feel you have the skills, and the appropriate tools, to perform the following service tasks please follow the instructions closely. The part numbers are listed throughout to help you when ordering parts from your local Cobra dealer.

If you don't feel comfortable with the service work, log on to www.cobramoto.com to find a Cobra dealer or Call 517-437-9100.

On board Diagnostics

4-0 Fault Recall function

This is a new function of the firmware as of version 3.1.2(introduced as a 2024 feature).

To recall the last recorded fault:

1. Power up bike or Turn off bike propulsion with the "Go" button.
2. Then hold down the "Mode" button for 10sec. (till all blue lights come on and the go off)
3. Flash code will be in the format (X Number of Flashes) Short Pause (Y Number of Flashes)
4. This will form the code as X-Y
5. Then refer the fault code chart for fault description.

Next page

Details on each one in a table below this one.

Blink Code	Description	E- Scope Code
1-1	ETS_PWR - Throttle sensor power fault	All TBD
1-2	NVM - Non volatile memory fault	
2-1	ETSA - Throttle sensor A fault	
2-1	ETSB - Throttle sensor B fault	8704
2-1	ETS_REDUND_CHECK - Throttle sensor redundancy fault	
	ETKS_SNS - ETKS sensed value outside of expected range	
3-1		
3-2	ETKS_UNST - ETKS key signal unstable	
3-2	ETKS_INV_STATE - Unrecognized ETKS key	
	MTR_SNS - Motor temperature sensor value outside of expected range	
4-1		
4-2	MTR_HIGH_TMP - Motor temperature too hot for operation	
4-3	MTR_RPM - Motor RPM too high	
4-4	PHASE_OC - Motor phase over-voltage	
5-1	MDU_COMM MDU - Communication fault	128
5-1	NET_COMM_TO - Communication timeout	
5-2	MDU_TMP MDU - Temperature too hot for operation	
5-2	CTL_OT - Controller too hot	
5-4	HSNS_FAULT - Hall sensor fault	
5-6	CTL_UV - Controller under-voltage	
5-7	POST_SGT - Phase On Self Test Static Gating Test	
5-8	POST_DGT - Phase On Self Test Dynamic Gating Test	
5-9	H_STALL - Hall stall	
6-2	INST_CTL_OV - Instantaneous controller overvoltage	
6-3	INTERNAL MDU - internal fault	
6-4	CAN - CAN bus	
6-4	TORQ_SNS - Torque Sensor	
6-4	BOOTLOAD - Bootloader issue	
6-4	PARAM2_CRC - Calibration programming	
6-4	H_SNS_POS - Hall sensor position	
6-4	MTR_OT - Motor over-temperature	
7-1	BATT_DEV - Battery fault	
7-2	BATT_COMM - Battery communication fault	

Motor Cooling Fluid Replacement

Radiator fluid removal:

- 8mm hex key
 - Motor Cooling Fluid (MCMUMF32)
1. Remove radiator cap and drain engine cooling fluid using the 8mm hex key and the drain at the bottom of the motor.

NOTE: Inspect the old coolant for evidence of metal or other debris that may indicate a problem.

2. Inspect the o’ring and replace if necessary.
3. Reinstall the drain plug. Snug
4. Fill the system with 500 ml of Cobra Motor Cooling Fluid. ‘Burp’ the system of trapped air by rotating the motorcycle back in a ‘wheelie’ (while on the stand) until the system is free of trapped air.



Rear wheel pullers

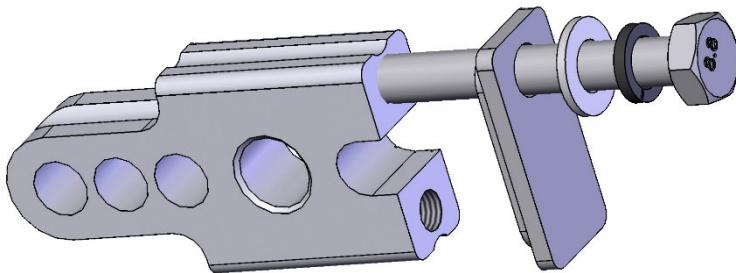

1. Remove axle, and back wheel assembly.
2. Pull the rear wheel pullers out of the back of the swing arm.

Rear wheel alignment:

By eye, ensure that the rear sprocket is running true (in-line, planar) with the front sprocket. When the sprockets are running true, the wheel is properly straightened, and the chain will run straight.

Brakes

Check before each ride:

- Make sure the brake does not have any leaks by holding the lever in while checking hose connections.
- Make sure the brake lever pressure is OK by pulling in on the lever and ensuring full braking performance is achieved before the lever touches the handlebar. If this is not the case, pump the lever several times until the lever feels firm.
- Always make sure the rotor and brake pads are free from oil and grease. Clean the rotor with mild dish soap or alcohol. Contaminated pads must be replaced.
- Ensure that the brake caliper is centered over the brake rotor. If a correction is needed, Cobra has thin brake shims to help make minor adjustments in alignment.
- Always leave adequate free-play in the lever or pedal.

CAUTION: This brake system uses only DOT 4 brake fluid!

Front Forks

The front forks are fully serviceable, but it is recommended that only trained professionals should service them. Contact Cobra for questions and service of your forks.

Rear Shock

The rear shock is fully serviceable but it is recommended that only trained professionals should service your shock. Contact Cobra for questions and service of your CX50 SR shock.

Tuning

Gearing

What happens with improper gearing?

- Poor performance
- Not enough top end speed
- No snap out of the corners
- No jump at the gate

Condition	Gear Taller	Gear Lower
Mud		↓ ↓
Sand		↓
Hills		↓
Hard Pack	↑	

Front Sprocket	Rear Sprocket	Gear Ratio		
	11	48	4.36	
	11	49	4.45	
	11	50	4.55	
	11	51	4.64	
	11	52	4.73	
10		48	4.80	
	11	53	4.82	
10		49	4.90	
	11	54	4.91	
10		50	5.00	<i>stock</i>
10		51	5.10	
10		52	5.20	
10		53	5.30	
10		54	5.40	

Front Fork Operation

The front suspension on the CX50SR works under the principals of hydraulic damping, and it features full adjustability to help tune the fork to meet each rider's needs. The CARD fork contains MXT 'Smart Leg' technology that provides very progressive operation; allowing a small bike to perform well on track surfaces ripped up by larger machines.

The key to Smart Leg technology is to understand that each leg has a different role. The brake side leg features a conventional open cartridge. This cartridge handles both standard compression and rebound damping duties. Rebound damping is adjustable on the fork cap, and compression damping is adjusted at the bottom of the fork. The other leg (the Smart Leg) has no rebound damping, and it contains both a speed sensitive compression damping mechanism as well as a position sensitive one. This design allows for a firm low speed response, controlling rapid chassis pitch, which promotes stability and control. The fork produces significantly less mid and high-speed compression until it travels into the progressive / speed sensitive portion of the smart leg. The speed sensitive compression component is adjustable at the top of the fork.

The combination of the Smart Leg and the conventional leg allows the fork to be very supple throughout all low amplitude operation and yet take punishing hits; producing a progressively increasing damping rate that slows the forks movement as it approaches full bottom. Therefore, the Smart Leg also acts as a hydraulic bottoming control device. Finally, the large degree of adjustability in both legs allows the fork to be tuned to meet each rider's size, ability, and type of riding they do (motocross, off-road, flat track, etc.)

Fork Damping Adjustments

Tools required

- Small flat blade screwdriver



REBOUND ADJUSTMENT

The speed at which the fork rebounds can be adjusted at the top of the conventional leg. Turning the adjustment screw clockwise slows the rate at which the fork extends after being compressed, and likewise, turning the screw counter-clockwise returns the leg to its extended position faster. As shown in the figure, 'S' (slower) and 'F' (faster) are etched into the cap as an adjustment guide.

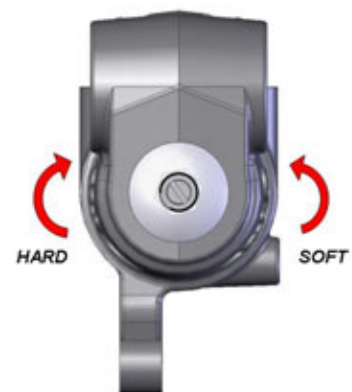

COMPRESSION ADJUSTMENT



At the base of the conventional leg is another adjustment screw that controls the amount of compression damping. Turning this screw clockwise increases damping and turning it counter-clockwise will decrease it. This is illustrated by the “HARD” and “SOFT” in the figure at the right.

The Smart Leg cap is labeled “Speed Sensitive Bottoming Control”, and this adjuster provides a range of control over how progressive the fork feels. Turning the screw clockwise increases the fork’s resistance to bottoming, while turning the screw counter-clockwise decreases it. On the track, this effect will be felt on

sections where the fork is forced to move very quickly such as on harsh landings or when traversing sharp edged bumps.

Rear Shock Adjustments

Always start with standard settings and make damping changes in no more than two click increments and only make one change at a time.

Symptom	Action
Rear end feels stiff on small bumps	Softer Low Speed Compression Damping
Rear end ‘sways’ on straights	Harder Low Speed Compression Damping
Bike tends to jump ‘rear end high’	Harder High Speed Compression
Bike tends to jump ‘rear end low’	Softer High Speed Compression
Frequent rear end bottoming	Harder Compression Damping
Bottoms after end of continuous bumps	Softer rebound damping
Rear end ‘kicks’ over square edge bumps	1) Harder rebound, 2) Softer Low and High Speed Compression
Rear end feels stiff under acceleration bumps.	Softer Rebound and/or Stiffer Low Speed Compression Damping

Proactive Suspension Adjustments

Once you have the suspension adjusted for decent overall feel, you can make proactive adjustments when faced with different racing conditions.

Situation	Actions
Sand track	Lower the rear end (increase race sag).
Sand track	Stiffer compression and rebound damping.
Long fast track	Lower the forks in the clamps by 3 mm.
Tight slow track	Raise the forks in the clamps by 3 mm.
Mud track	Lower the bike if the rider has difficulties touching the ground.

Shock preload

Loosen the set screw and turn the spring perch in full turn increments to get the desired sag settings.

NOTE:

Always leave the spring perch rotated in such position so that the set screw is easily accessible.

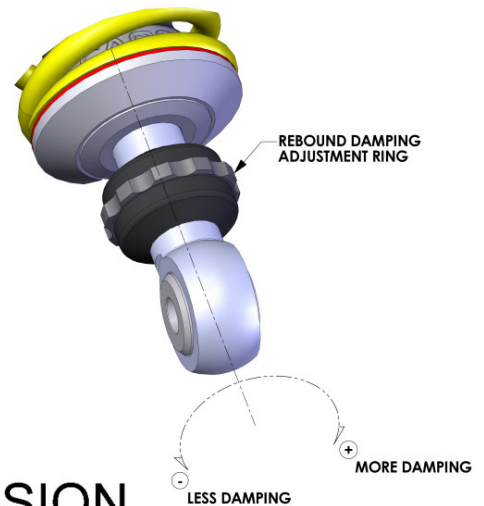

Shock Damping

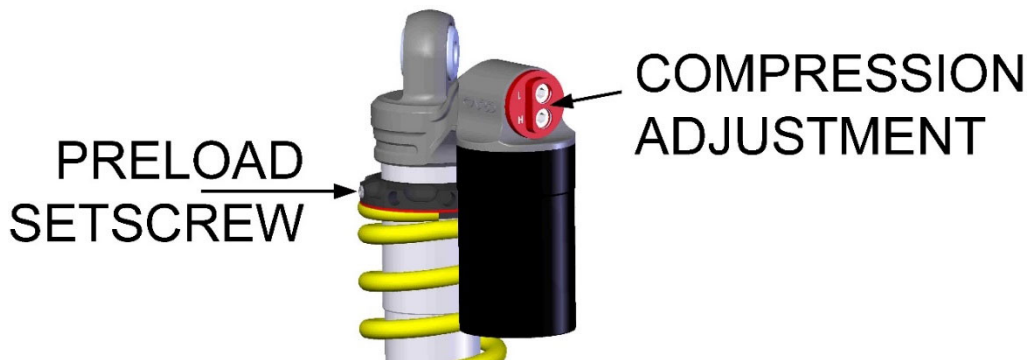

The Low Speed “L” adjustment is what controls how quickly the rear of the bike settles in the corners or how it settles in sweeping ‘flat track’ style corners whereas the High Speed “H” adjustment controls how the shock reacts to kickers. In “+” adds damping or slows it down, whereas out, “-“ speeds up the shock or removes damping.

Troubleshooting

- **RDU Lower Left Fault light: Battery Fault**
- **RDU Lower Right Fault Light: Electrical System**
- **Bike doesn't run at all, RDU Lower Red Fault light is On solid.**
 - ***For 2024 and newer bikes, please refer to the Flash Code Diagnostics
- **Bike is slow and coolant smells burnt?**
 - Replace motor and coolant
- **Bike doesn't run at all, RDU Lower right Red Fault light flashes with turning rear wheel.**
 - Change hall sensor board
- **If bike has just been washed with or without battery:**
 - Allow ample time to dry before powering back up.
- **Motor has extra high drag, runs rough or seal leaking:**
 - Possible bearing issue, replace motor/have motor serviced
- **Bike doesn't have the power it did:**
 - Check for binding / oil the chain (other maintenance)
 - Ensure it has latest software
 - Does bike have 150+ cycles on battery? If yes, may be time for replacement/refresh.
 - Check for loose high power connections. (Main power and Motor Phase Wires)
 - Change Controller and test.

Change Control

Who	Rev	Date Pub	Assy/pg	Changes made
PDM	1	8/23/24	Rear wheel and spec table	Chain length is 110L
PDM	2	8/28/24	Added do's and don'ts to index	Added "no grease" to do's and don't's list
PDM	3	NOT	Do's and don't's	Added "turn off battery"
PDM	3	9/10/24	Bodywork	Updated bodywork kits
PDM	4	9/24/24	Warranty Disclaimer page LI battery page - added	Updated verbiage.
PDM	5	NOT YET	Rear brakes	Corrected rear master part number
PDM	5	10/22/24	FRAME	Chain slide from FAMU002 to FCCEMU001 molded
PDM	6		Motor assy	Updated Motor Sensor Module to V2 & o'rings
PDM	6	11/12/24	Swingarm page	Shock bolt to HCBF1039 from HCBF1040
PDM	7		Electrical / controller	Added POST blocker board
	7		Forks & T clamp	All numbers were off
PDM	7	11/22/24	throughout	Updated hardware #'s
PDM	8	1/15/25	Torque specs	Front axle retaining bolt 12-15Nm was 25Nm